

9 8 7 6 5 4 3 2 1

G
F
E
D
C
B
A

G
F
E
D
C
B
A

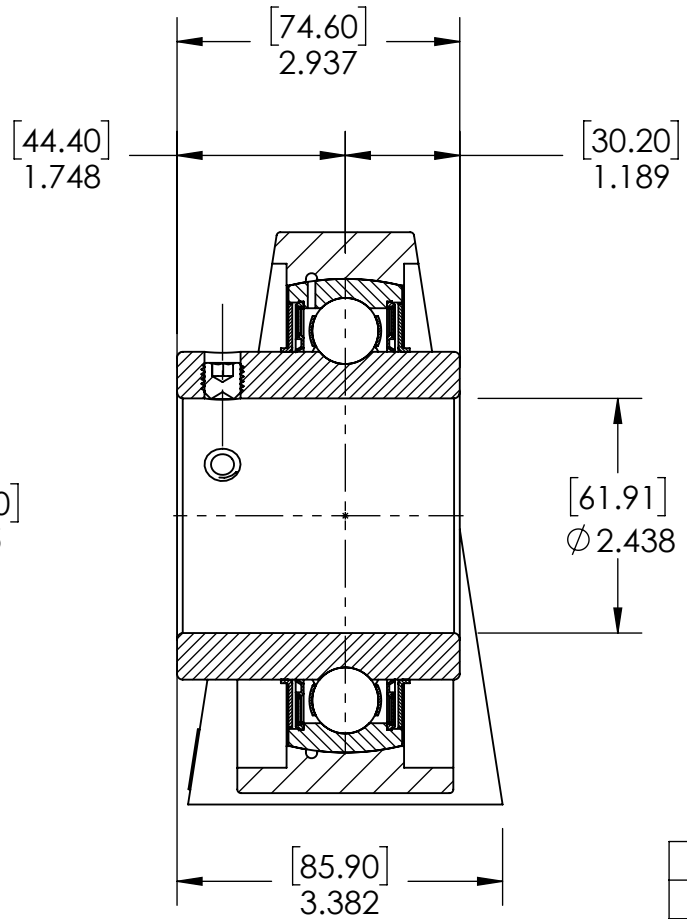
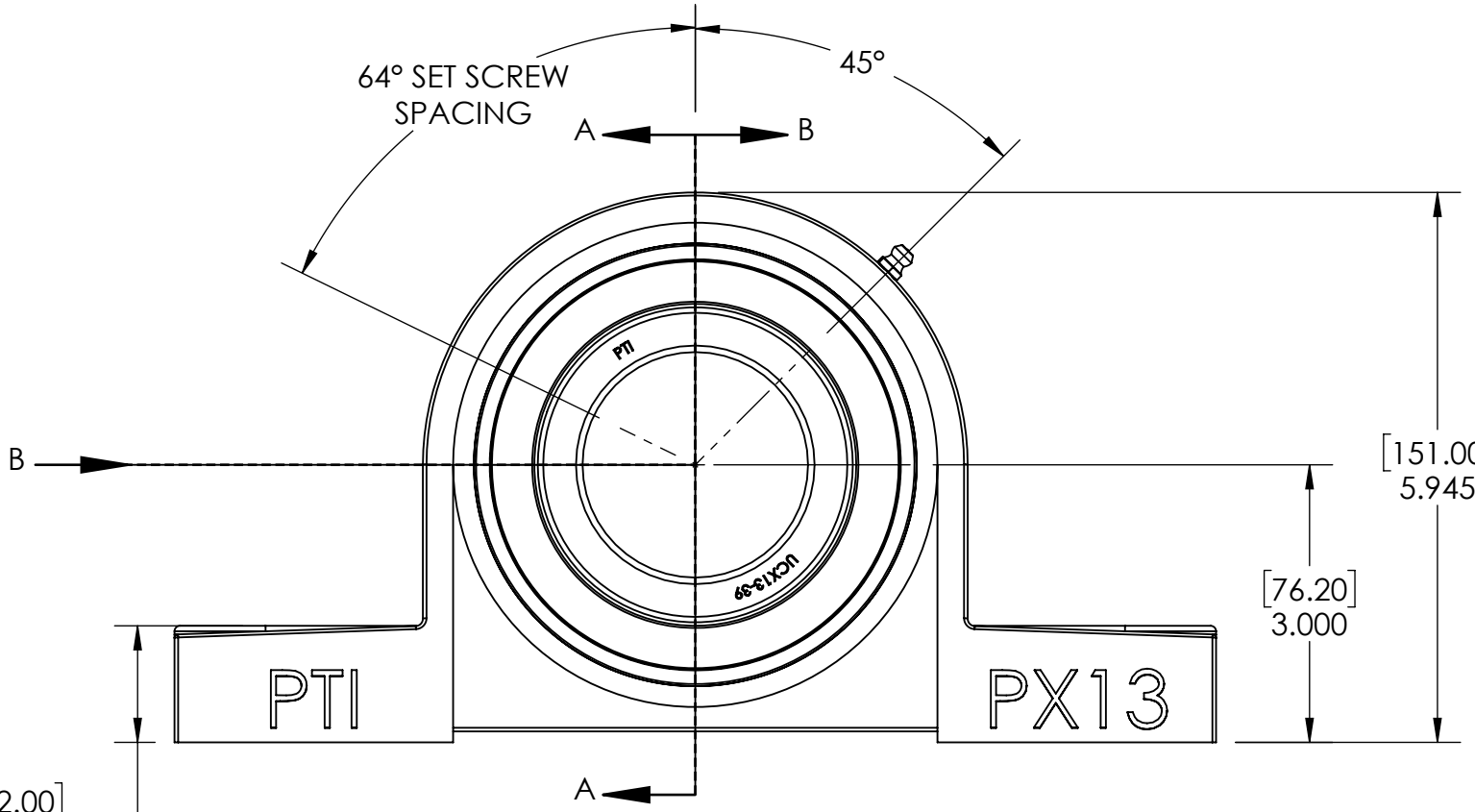
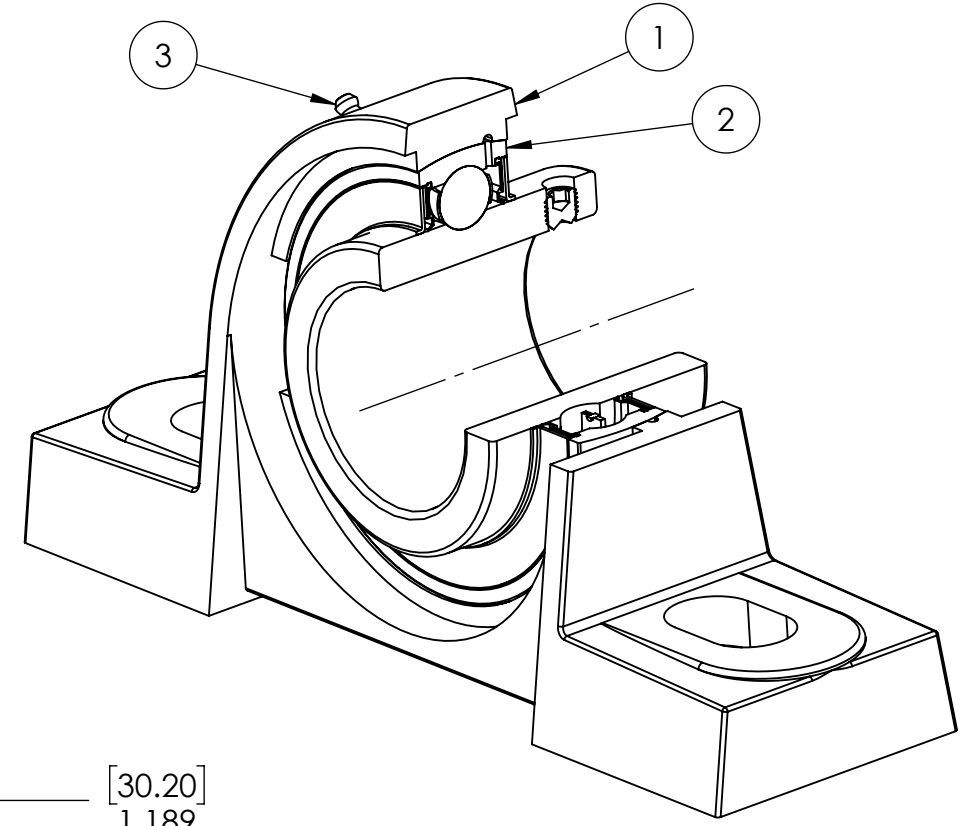
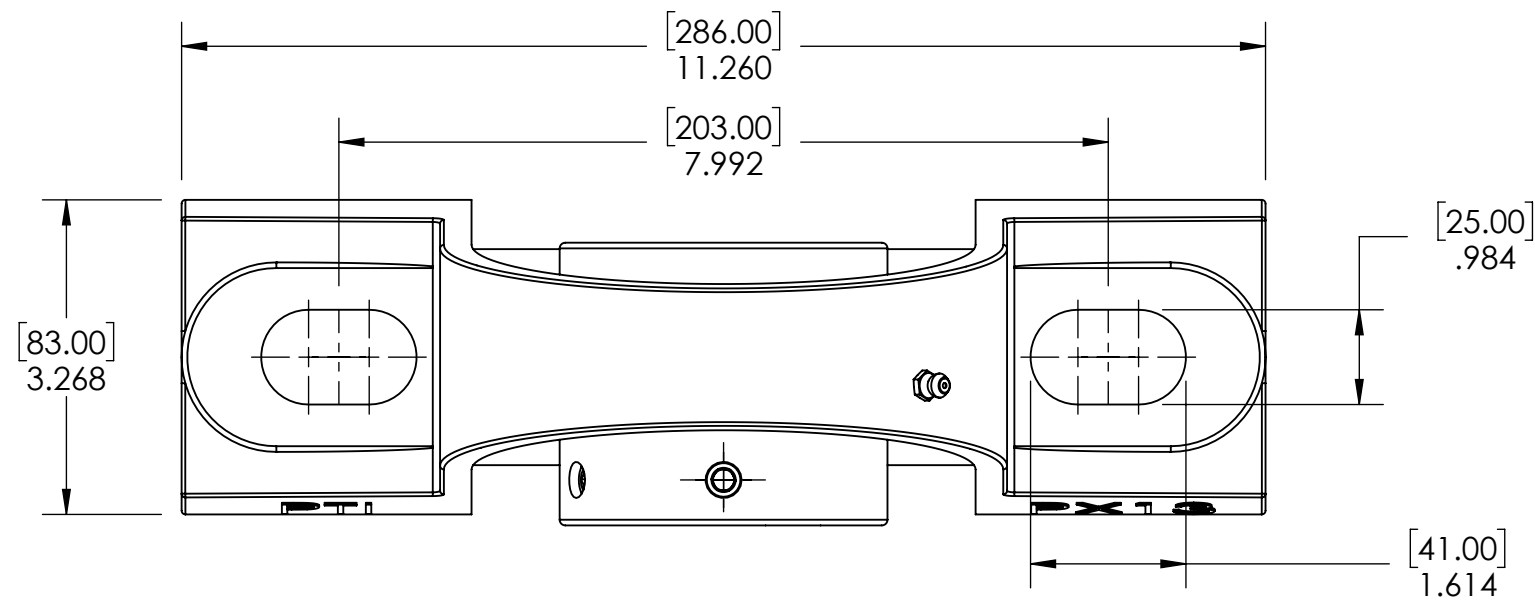

ITEM NO.	PART NUMBER	MATERIAL	COATING	QTY.
3	M6 ZERK	STEEL	ZINC PLATED	1
2	UCX13-39	BEARING STEEL	N/A	1
1	PX13	CAST IRON	POWDER COAT	1

SPECIFICATIONS	
UNITS:	IN [mm]
LOAD RATINGS	C: 14,000 LBS Co: 9,900 LBS
SPEED RATING	2450 RPM
GREASE TYPE	NLGI #2
GREASE FILL	40%
OPERATING TEMP	10°F - 200°F
SEAL TYPE	B-TYPE
INTERNAL CLEARANCE	C3
TORQUE SETTING ON SET SCREWS	

SOLVE INDUSTRIAL MOTION GROUP
PTI
 DWG. NO.

WEIGHT	14.54 LBS
MATERIAL	SEE BOM
COATING	SEE BOM
DRAWN	SEC 12/26/2024
CHECKED	KODS 01/06/2025
APPROVED	

DATE	BY	REVISION DESCRIPTION	REV
		UCPX13-39	1
			2
			3

9 8 7 6 5 4 3 2 1