

9 8 7 6 5 4 3 2 1

G F E D C B A

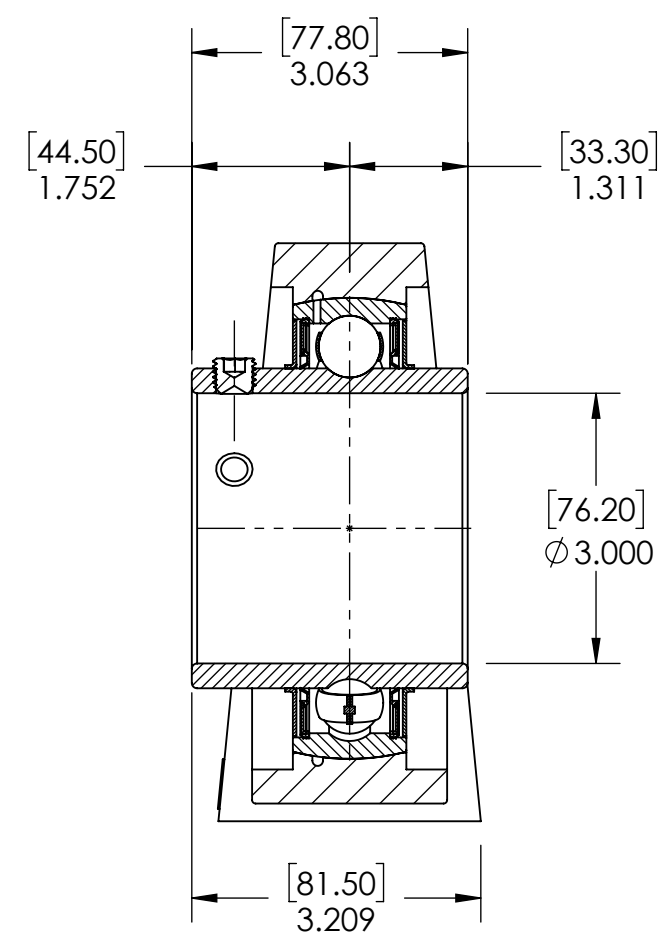
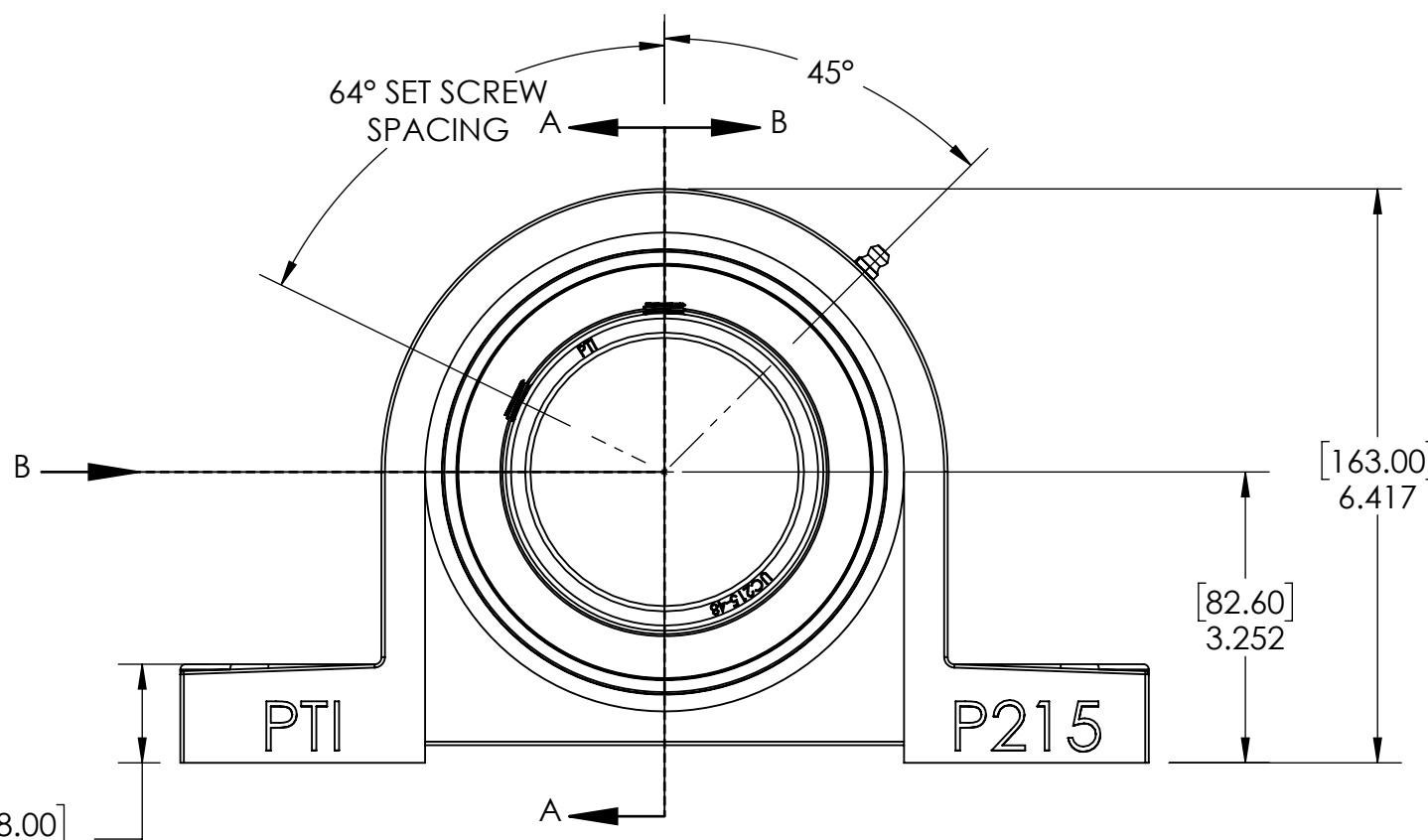
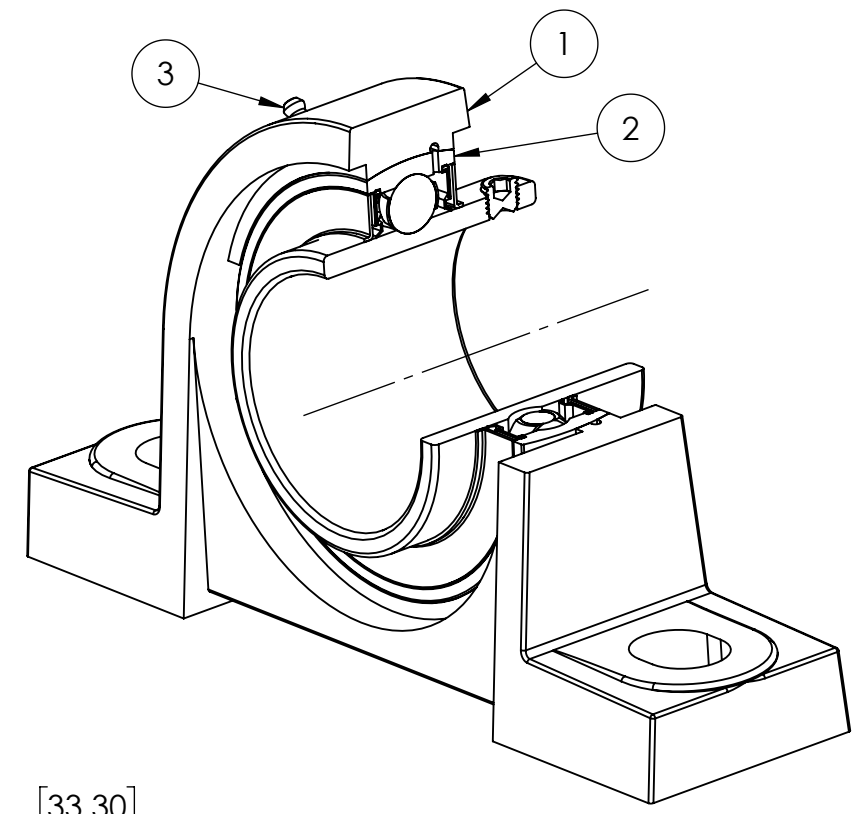
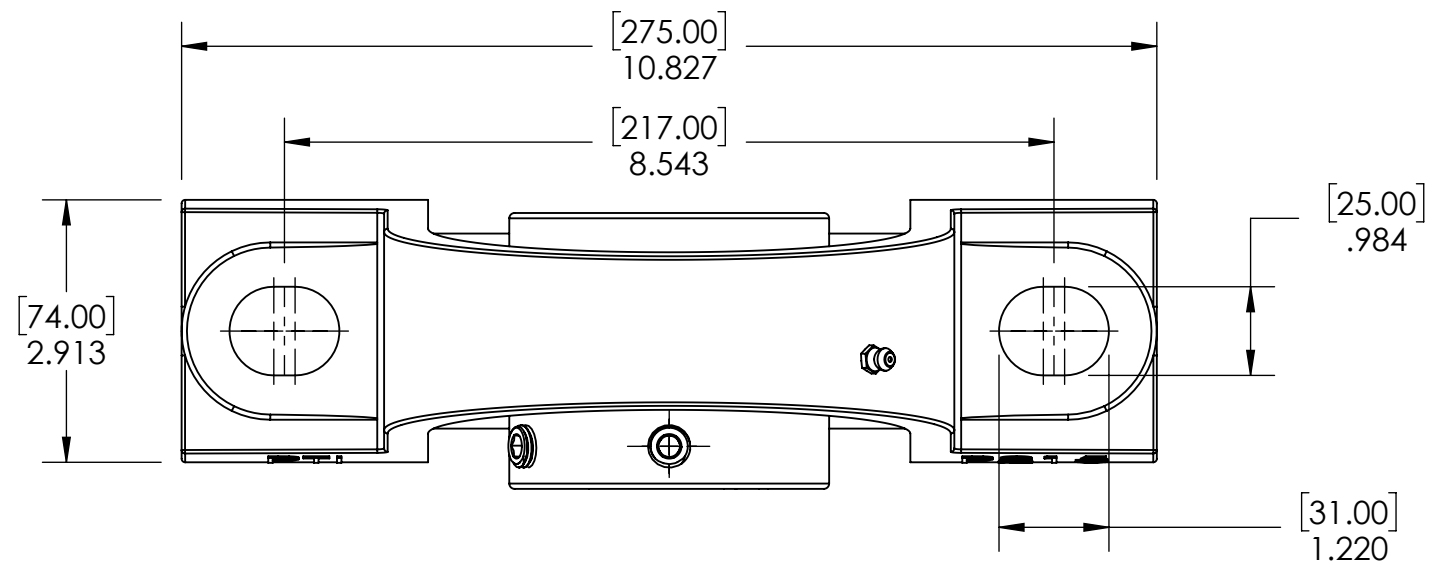

ITEM NO.	PART NUMBER	MATERIAL	COATING	QTY.
3	M6 ZERK	STEEL	ZINC PLATED	1
2	UC215-48	BEARING STEEL	N/A	1
1	P215	CAST IRON	POWDER COAT	1

SPECIFICATIONS	
UNITS:	IN (mm)
LOAD RATINGS	C: 14000 LBS Co: 10050 LBS
SPEED RATING	2300 RPM
GREASE TYPE	NLGI #2
GREASE FILL	40%
OPERATING TEMP	10°F - 200°F
SEAL TYPE	B-TYPE
INTERNAL CLEARANCE	C3
TORQUE SETTING ON SET SCREWS	

**SOLVE** INDUSTRIAL MOTION GROUP  
**PTI**  
 DWG. NO.

WEIGHT	14.47 LBS
MATERIAL	SEE BOM
COATING	SEE BOM
DRAWN	SEC 12/13/2024
CHECKED	FP 01/02/2025
APPROVED	

DATE	BY	REVISION DESCRIPTION	REV
ITEM DESCRIPTION: UCP215-48			SCALE 1:5
			REV -

9 8 7 6 5 4 3 2 1

A B C D E F G