

9 8 7 6 5 4 3 2 1

G F E D C B A

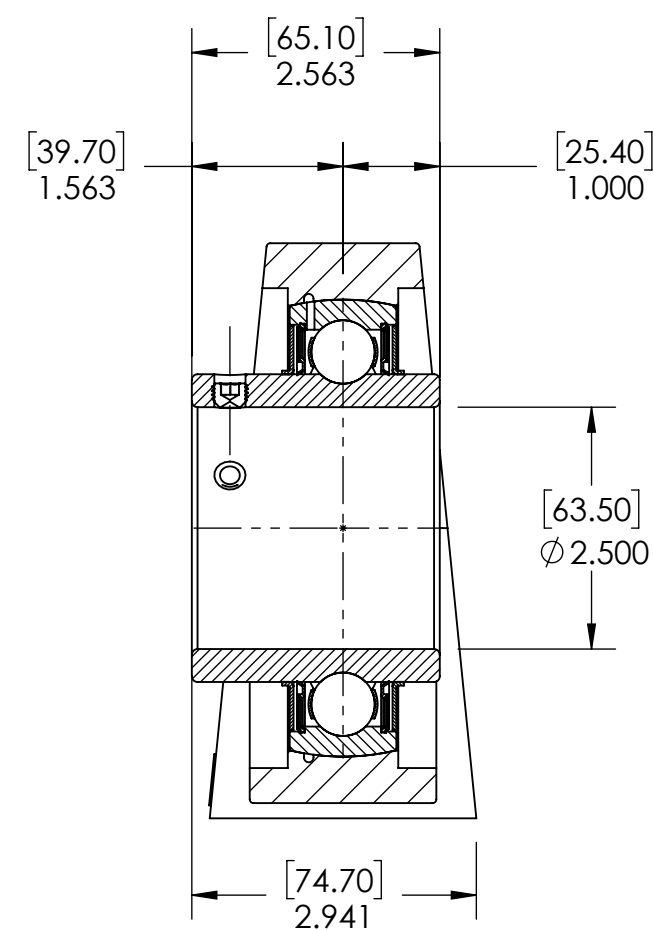
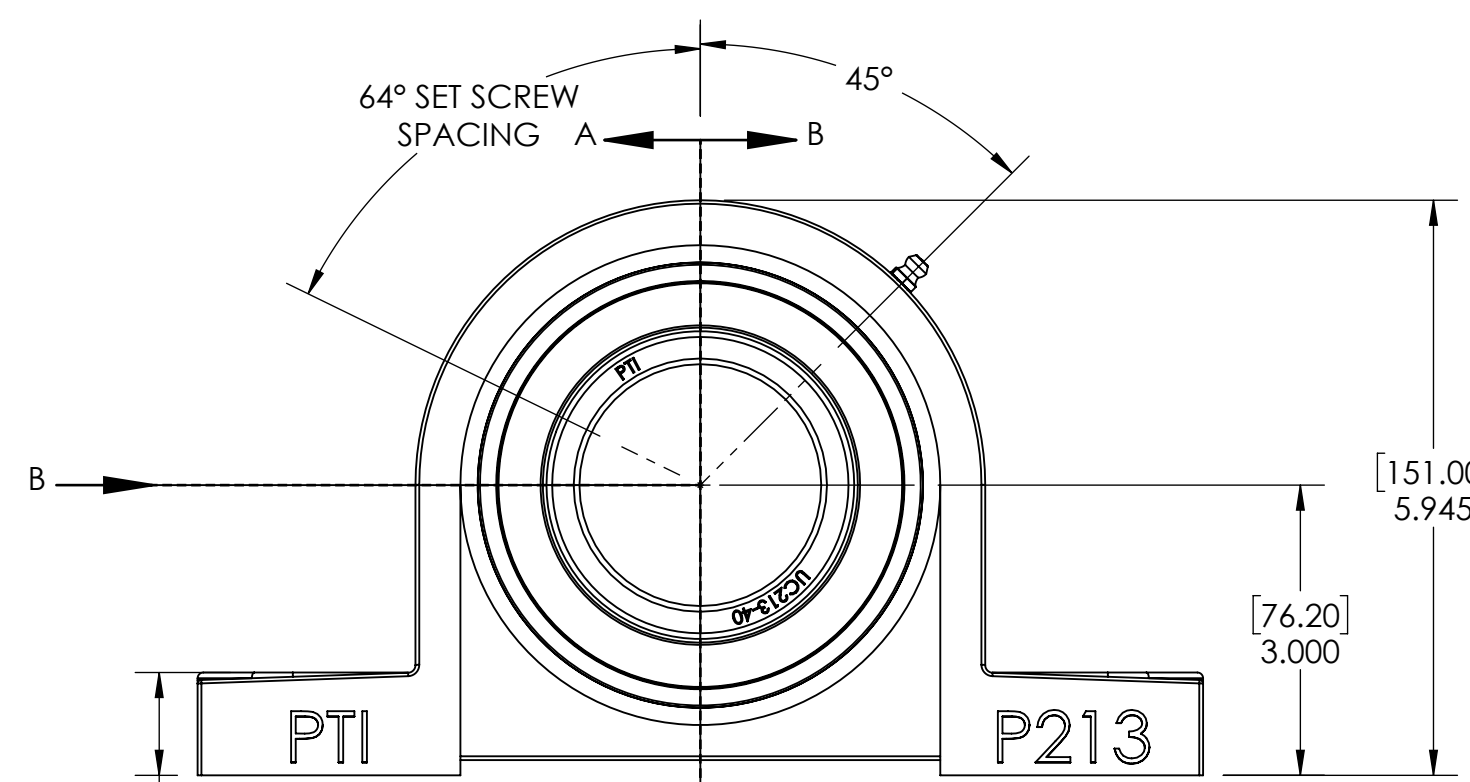
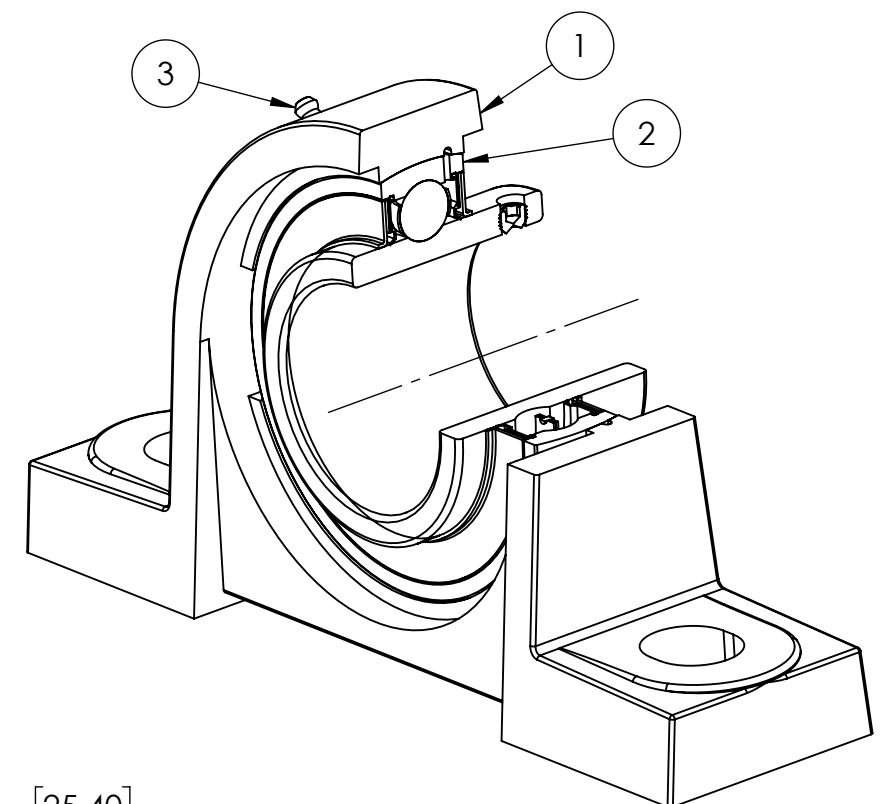
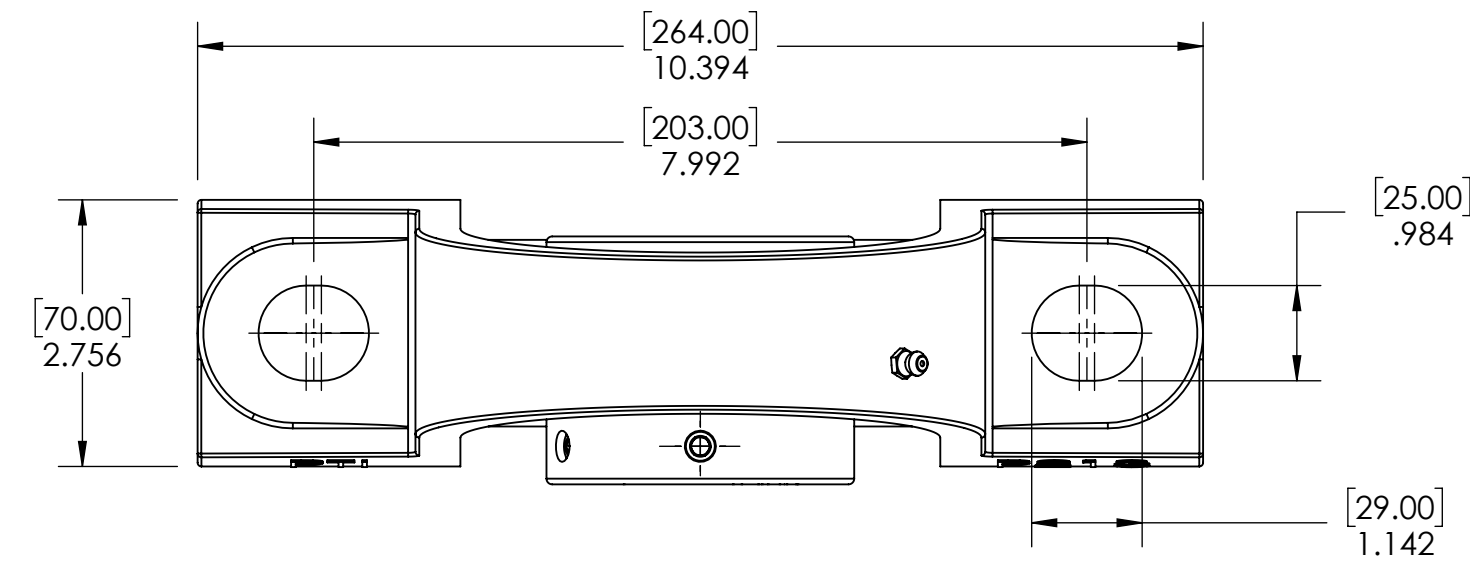

SECTION VIEW A-A

ITEM NO.	PART NUMBER	MATERIAL	COATING	QTY.
3	M6 ZERK	STEEL	ZINC PLATED	1
2	UC213-40	BEARING STEEL	N/A	1
1	P213	CAST IRON	POWDER COAT	1

SPECIFICATIONS	
UNITS:	IN (mm)
LOAD RATINGS	C: 13800 LBS Co: 9890 LBS
SPEED RATING	2600 RPM
GREASE TYPE	NLGI #2
GREASE FILL	40%
OPERATING TEMP	10°F - 200°F
SEAL TYPE	B-TYPE
INTERNAL CLEARANCE	C3
TORQUE SETTING ON SET SCREWS	

**SOLVE**  
INDUSTRIAL MOTION GROUP

SIZE **PTI**

DWG. NO.

WEIGHT	12.20 LBS
MATERIAL	SEE BOM
COATING	SEE BOM
DRAWN	SEC 12/13/2024
CHECKED	FP 01/02/2025
APPROVED	
THIRD ANGLE PROJECTION	
<small>PROPRIETARY AND CONFIDENTIAL THE INFORMATION CONTAINED IN THIS DRAWING IS THE SOLE PROPERTY OF SOLVE IMG. ANY REPRODUCTION IN PART OR AS A WHOLE WITHOUT THE WRITTEN PERMISSION OF SOLVE IMG IS PROHIBITED.</small>	

DATE	BY	REVISION DESCRIPTION	REV
ITEM DESCRIPTION: UCP213-40			SCALE 1:6
			REV -

9 8 7 6 5 4 3 2 1

A B C D E F G