

9 8 7 6 5 4 3 2 1

G G

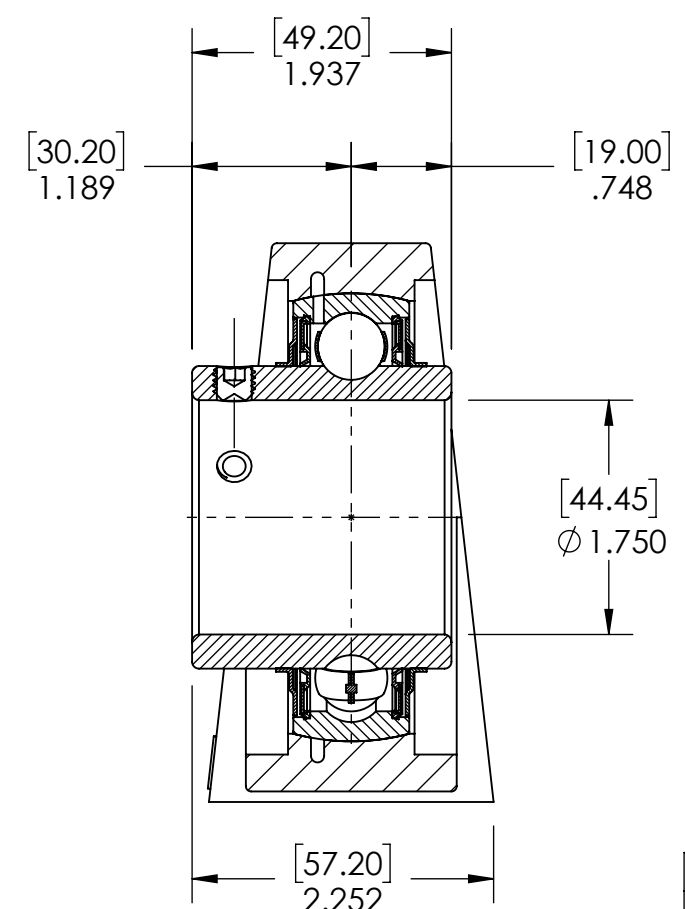
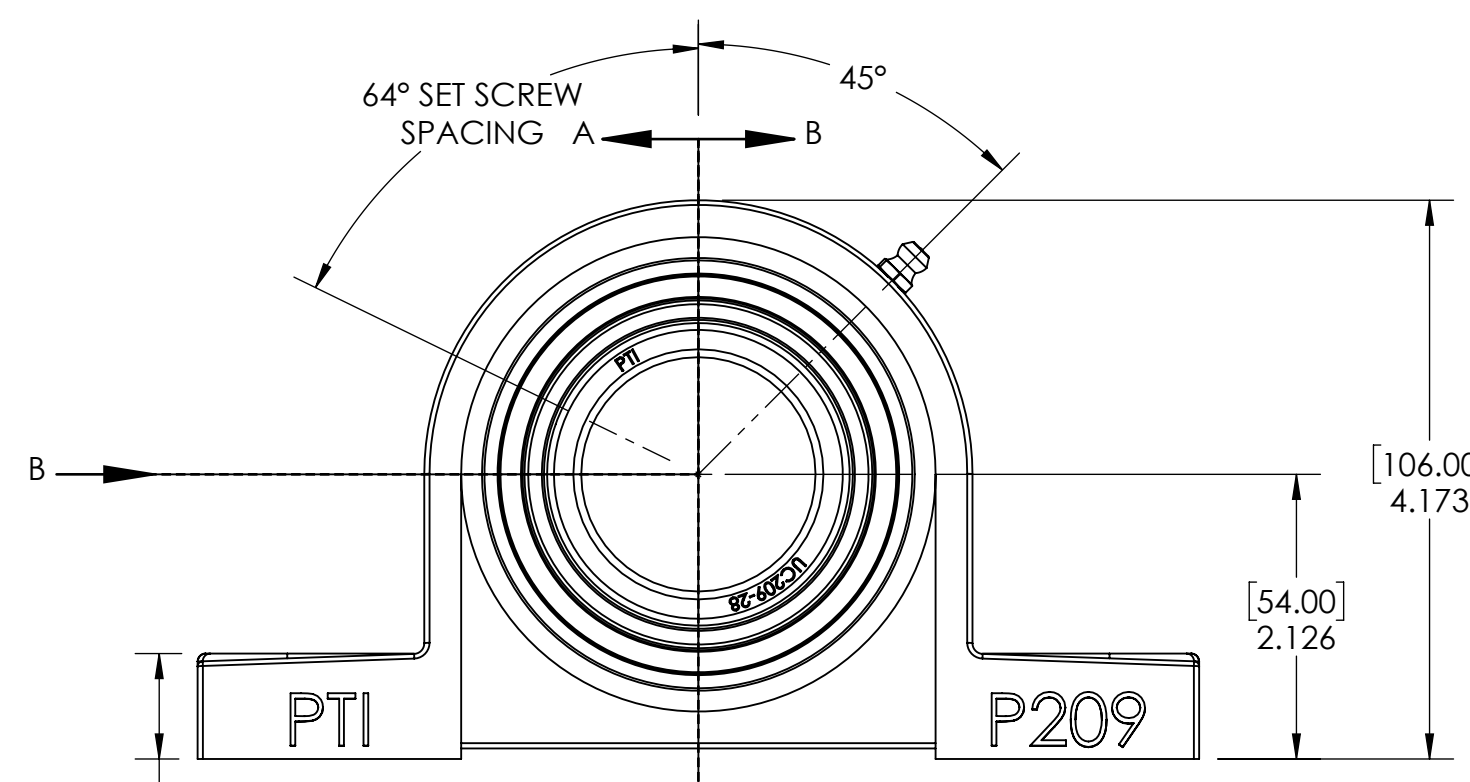
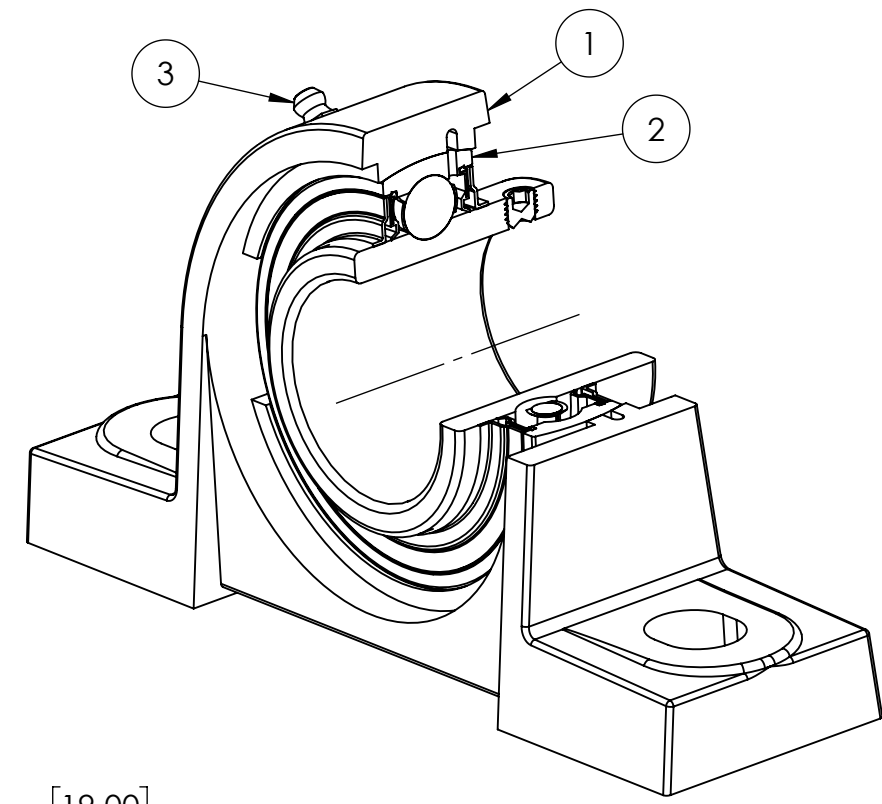
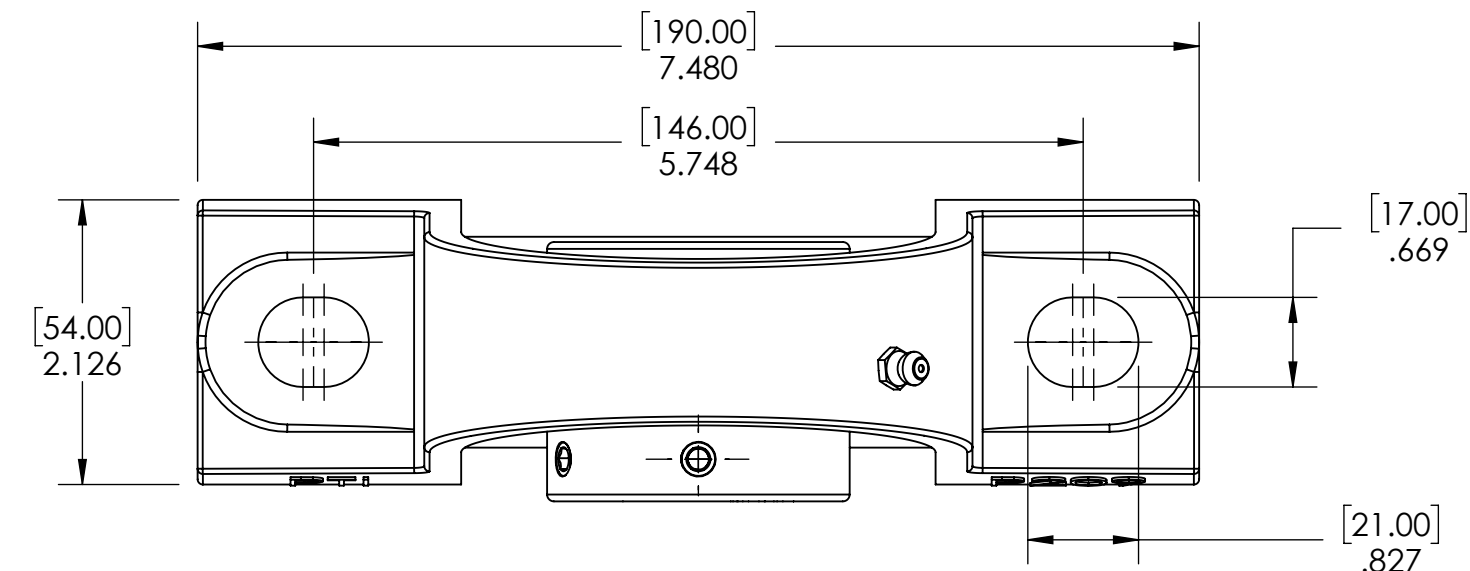

SECTION VIEW A-A

ITEM NO.	PART NUMBER	MATERIAL	COATING	QTY.
3	M6 ZERK	STEEL	ZINC PLATED	1
2	UC209-28	BEARING STEEL	N/A	1
1	P209	CAST IRON	POWDER COAT	1

SPECIFICATIONS		WEIGHT	
UNITS:	IN [mm]		4.71 LBS
LOAD RATINGS	C: 7390 LBS Co: 4610 LBS	MATERIAL	SEE BOM
SPEED RATING	3700 RPM	COATING	SEE BOM
GREASE TYPE	NLGI #2	DRAWN	SEC 12/13/2024
GREASE FILL	40%	CHECKED	FP 01/02/2025
OPERATING TEMP	10°F - 200°F	APPROVED	
SEAL TYPE	B-TYPE	THIRD ANGLE PROJECTION	
INTERNAL CLEARANCE	C3		
TORQUE SETTING ON SET SCREWS			

SOLVE INDUSTRIAL MOTION GROUP
PTI
 DWG. NO. PROPRIETARY AND CONFIDENTIAL
 THE INFORMATION CONTAINED IN THIS DRAWING IS THE SOLE PROPERTY OF SOLVE IMG. ANY REPRODUCTION IN PART OR AS A WHOLE WITHOUT THE WRITTEN PERMISSION OF SOLVE IMG IS PROHIBITED.

DATE	BY	REVISION DESCRIPTION	REV
		ITEM DESCRIPTION: UCP209-28	SCALE 1:8
			REV -

A A

9 8 7 6 5 4 3 2 1