

9 8 7 6 5 4 3 2 1

G
F
E
D
C
B
A

G
F
E
D
C
B
A

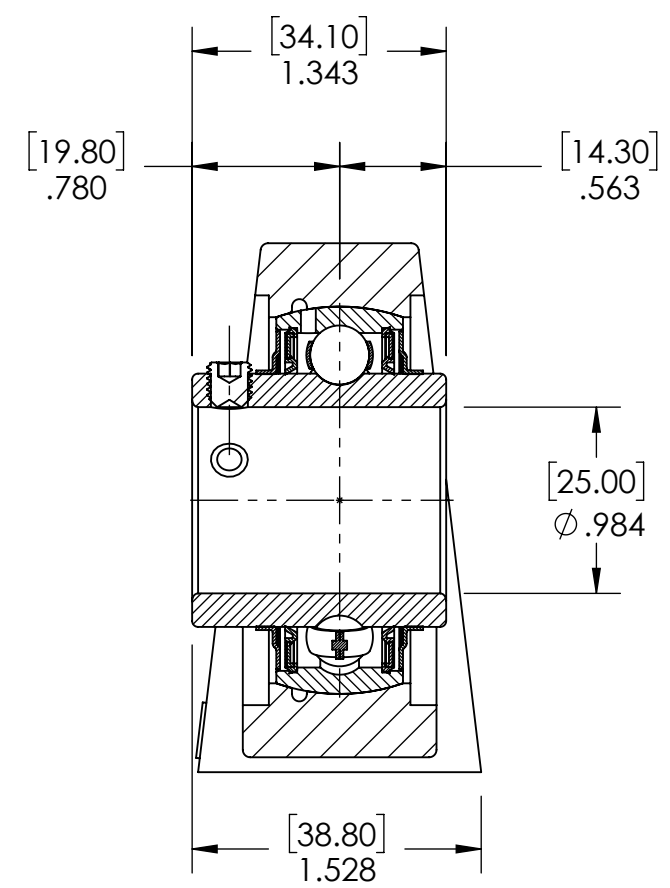
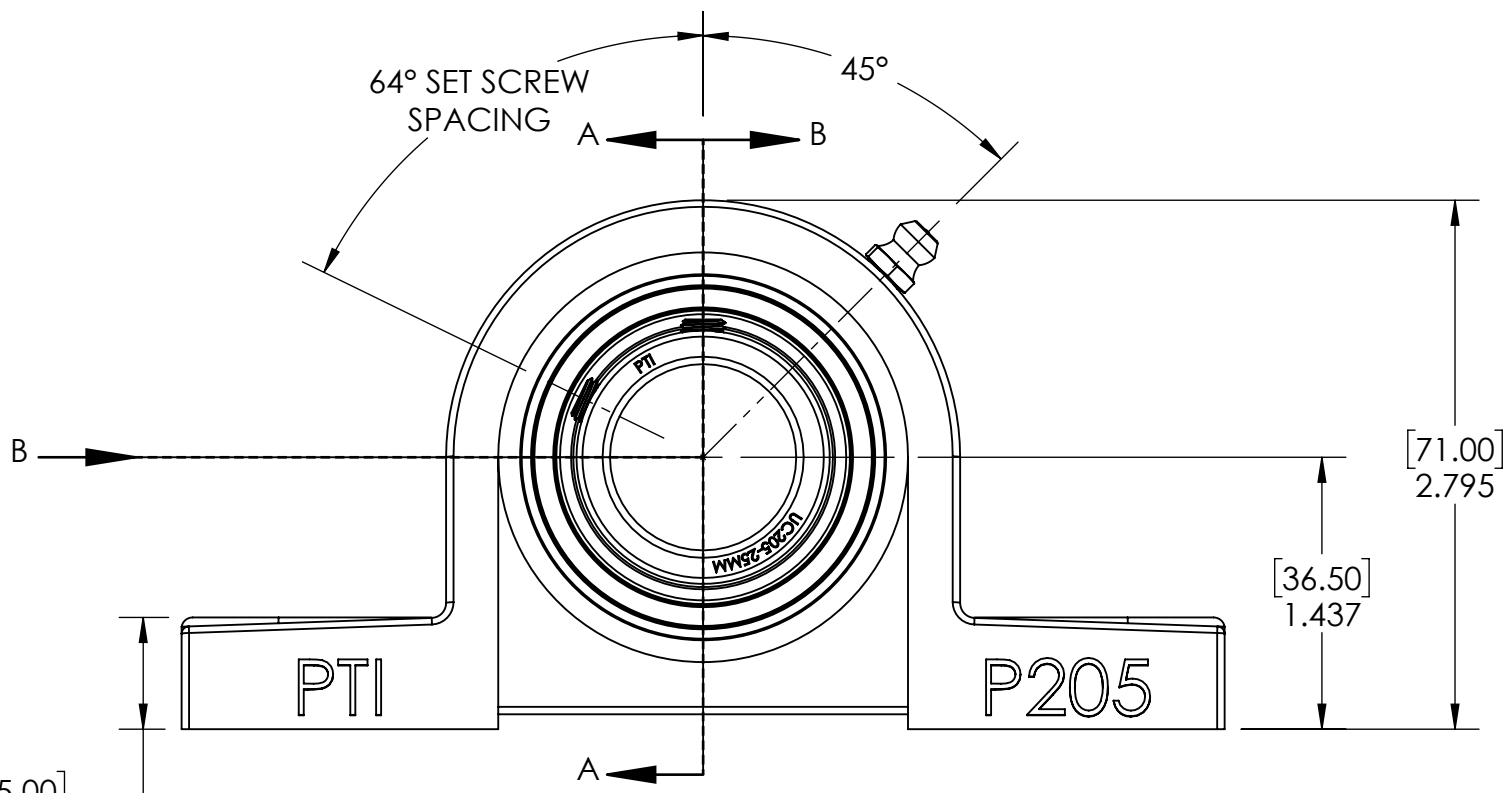
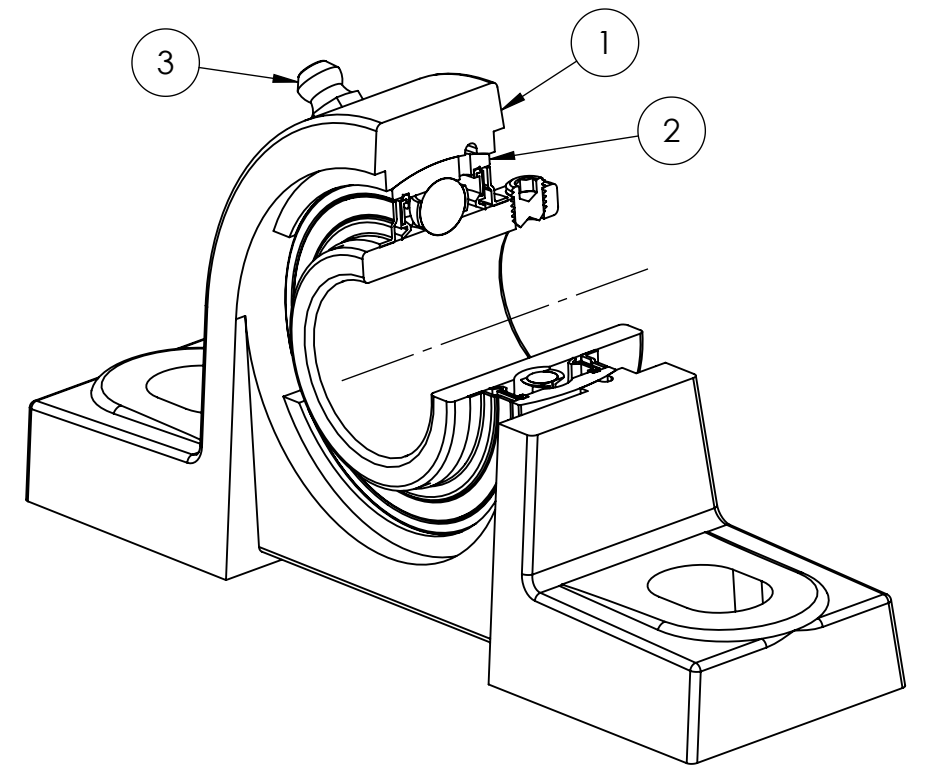
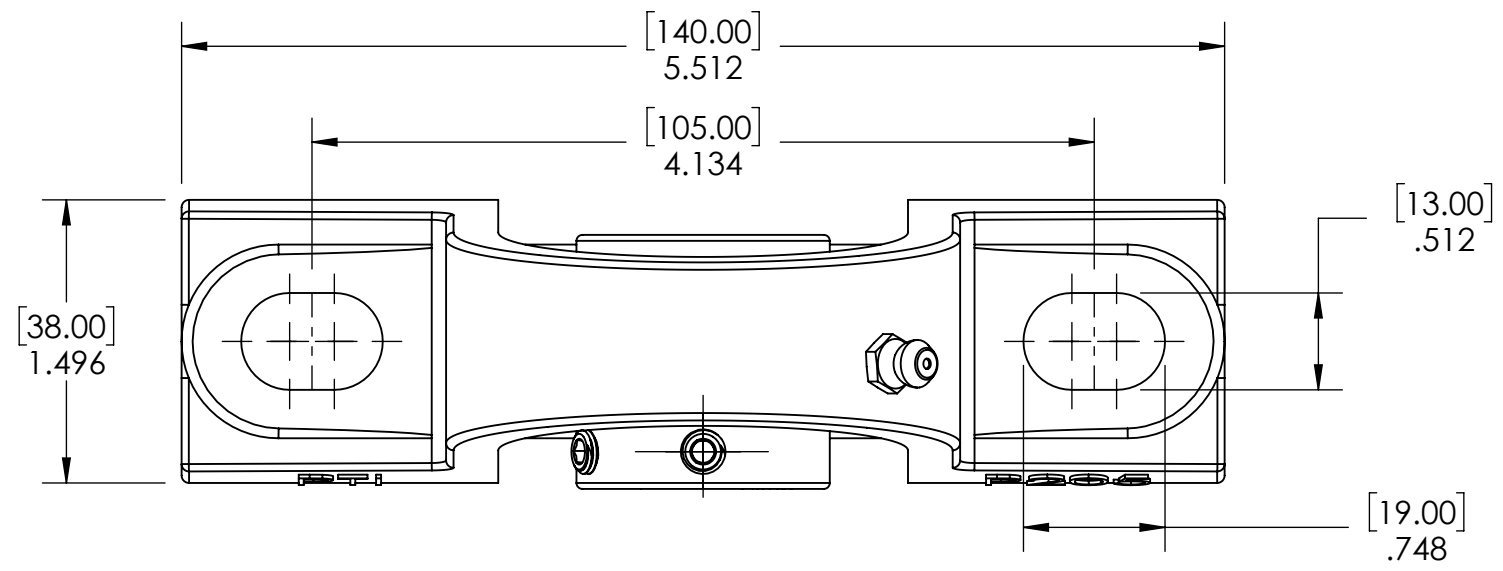

SECTION VIEW A-A

3	M6 ZERK	STEEL	ZINC PLATED	1
2	UC205-25MM	BEARING STEEL	N/A	1
1	P205	CAST IRON	POWDER COAT	1
ITEM NO.	PART NUMBER	MATERIAL	COATING	QTY.

SPECIFICATIONS	
UNITS:	IN (mm)
LOAD RATINGS	C: 3140 LBS Co: 1750 LBS
SPEED RATING	6250 RPM
GREASE TYPE	NLGI #2
GREASE FILL	40%
OPERATING TEMP	10°F - 200°F
SEAL TYPE	B-TYPE
INTERNAL CLEARANCE	C3
TORQUE SETTING ON SET SCREWS	

SOLVE
INDUSTRIAL MOTION GROUP

SIZE **B**

PTI

DWG. NO.

WEIGHT	1.69 LBS
MATERIAL	SEE BOM
COATING	SEE BOM
DRAWN	SEC 12/13/2024
CHECKED	FP 01/02/2025
APPROVED	
THIRD ANGLE PROJECTION	

DATE	BY	REVISION DESCRIPTION	REV
ITEM DESCRIPTION: UCP205-25MM			SCALE 1:11
			REV -

9 8 7 6 5 4 3 2 1