

9 8 7 6 5 4 3 2 1

G F E D C B A

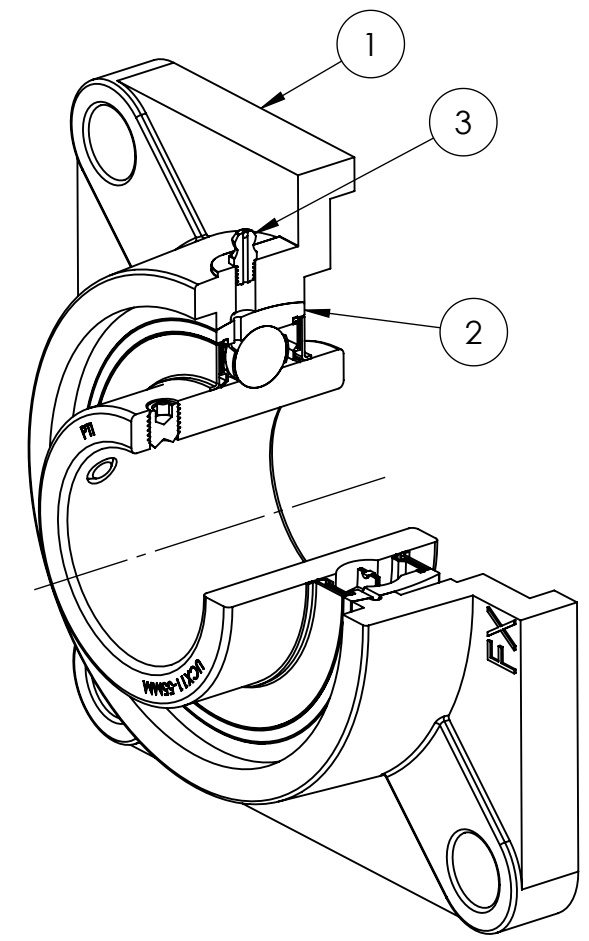
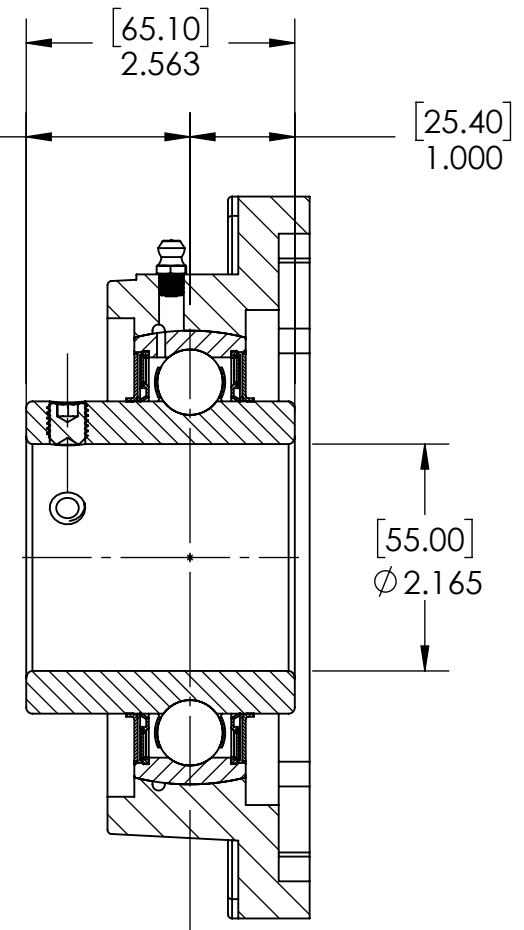
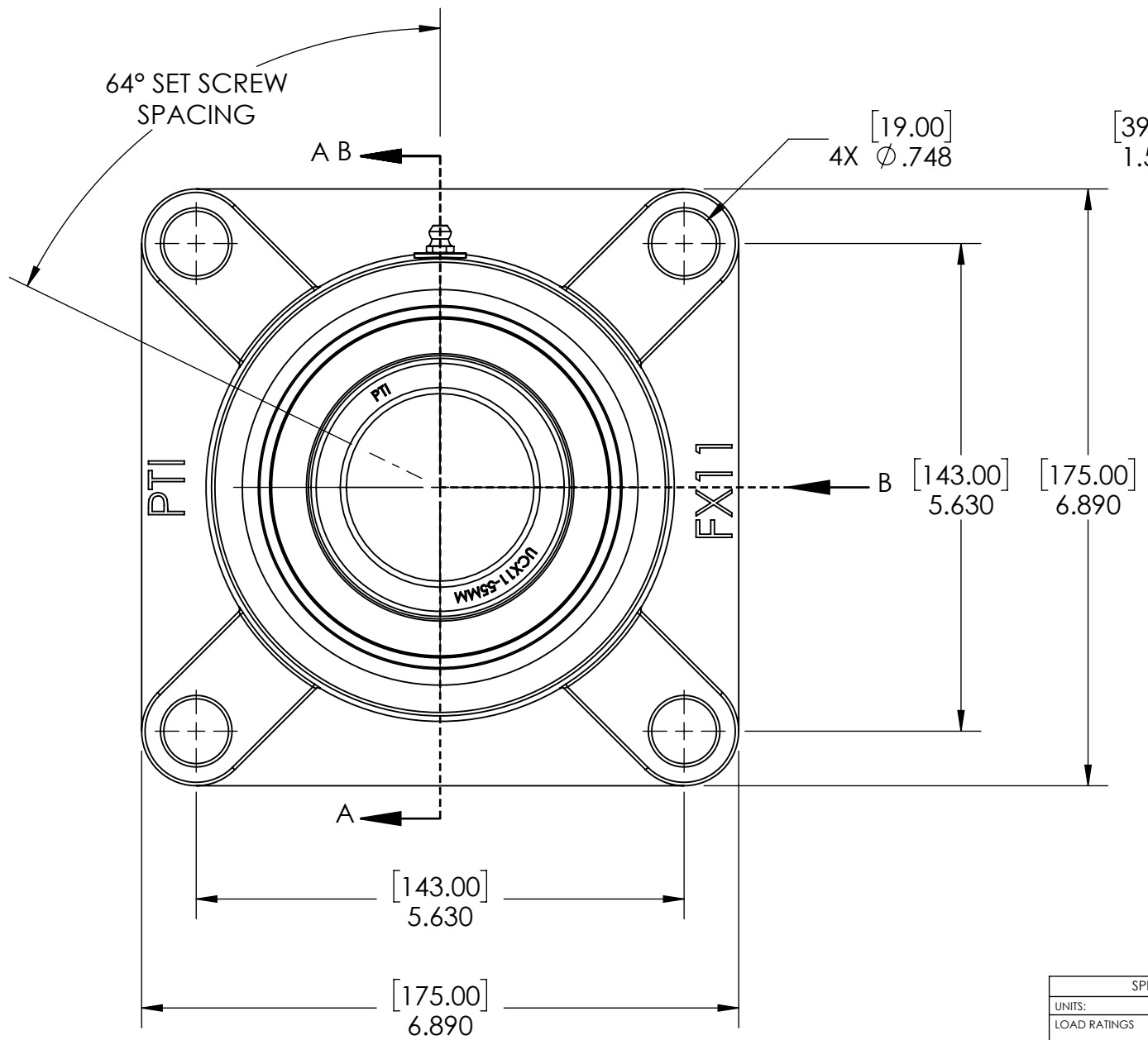
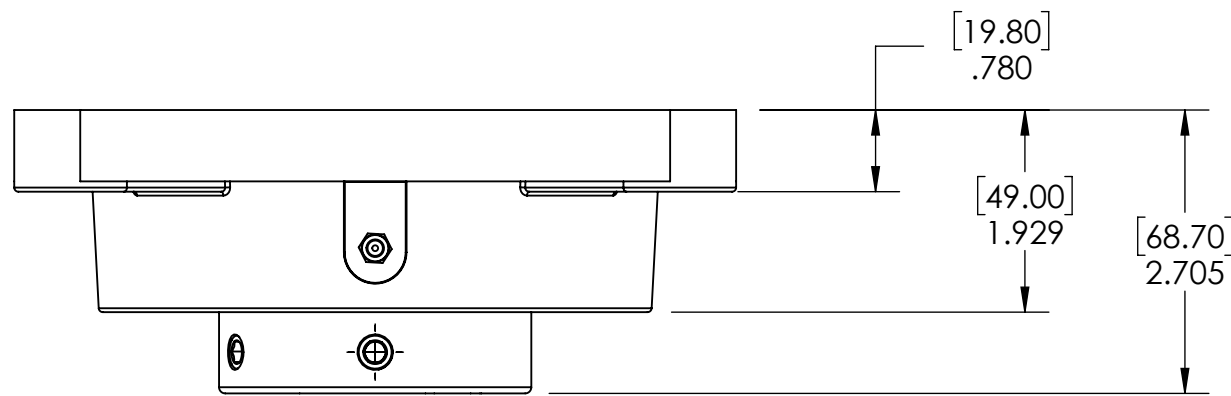

ITEM NO.	PART NUMBER	MATERIAL	COATING	QTY.
3	M6 ZERK	STAINLESS STEEL	N/A	1
2	UCX11-55MM	BEARING STEEL	N/A	1
1	FX11	STAINLESS STEEL	POWDER COAT	1

SPECIFICATIONS		SOLVE INDUSTRIAL MOTION GROUP		WEIGHT	
UNITS:	IN [mm]	SIZE	B	9.75 LBS	
LOAD RATINGS	C: 11,800 LBS Co: 8,150 LBS	DWG. NO.		MATERIAL	SEE BOM
SPEED RATING	2800 RPM			COATING	SEE BOM
GREASE TYPE	NLGI #2			DRAWN	SEC 01/03/2025
GREASE FILL	40%			CHECKED	KODS 01/06/2025
OPERATING TEMP	10°F - 200°F			APPROVED	
SEAL TYPE	B-TYPE			THIRD ANGLE PROJECTION	
INTERNAL CLEARANCE	C3			PROPRIETARY AND CONFIDENTIAL	
TORQUE SETTING ON SET SCREWS				THE INFORMATION CONTAINED IN THIS DRAWING IS THE SOLE PROPERTY OF SOLVE IMG. ANY REPRODUCTION IN PART OR AS A WHOLE WITHOUT THE WRITTEN PERMISSION OF SOLVE IMG IS PROHIBITED.	

DATE	BY	REVISION DESCRIPTION	REV
		ITEM DESCRIPTION: UCX11-55MM	SCALE 1:7
			REV -

9 8 7 6 5 4 3 2 1

A B C D E F G