

9 8 7 6 5 4 3 2 1

G F E D C B A

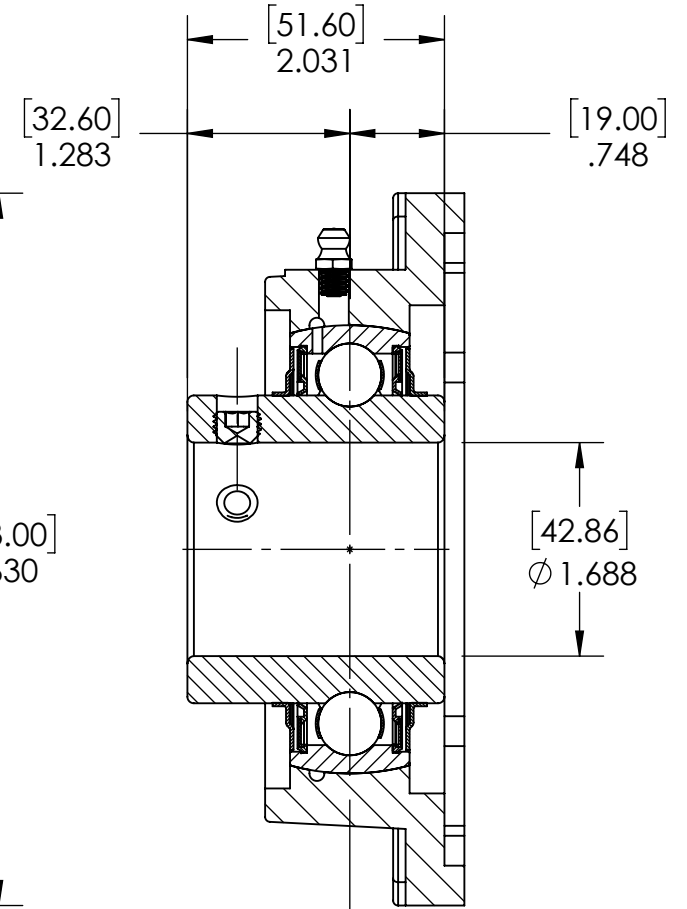
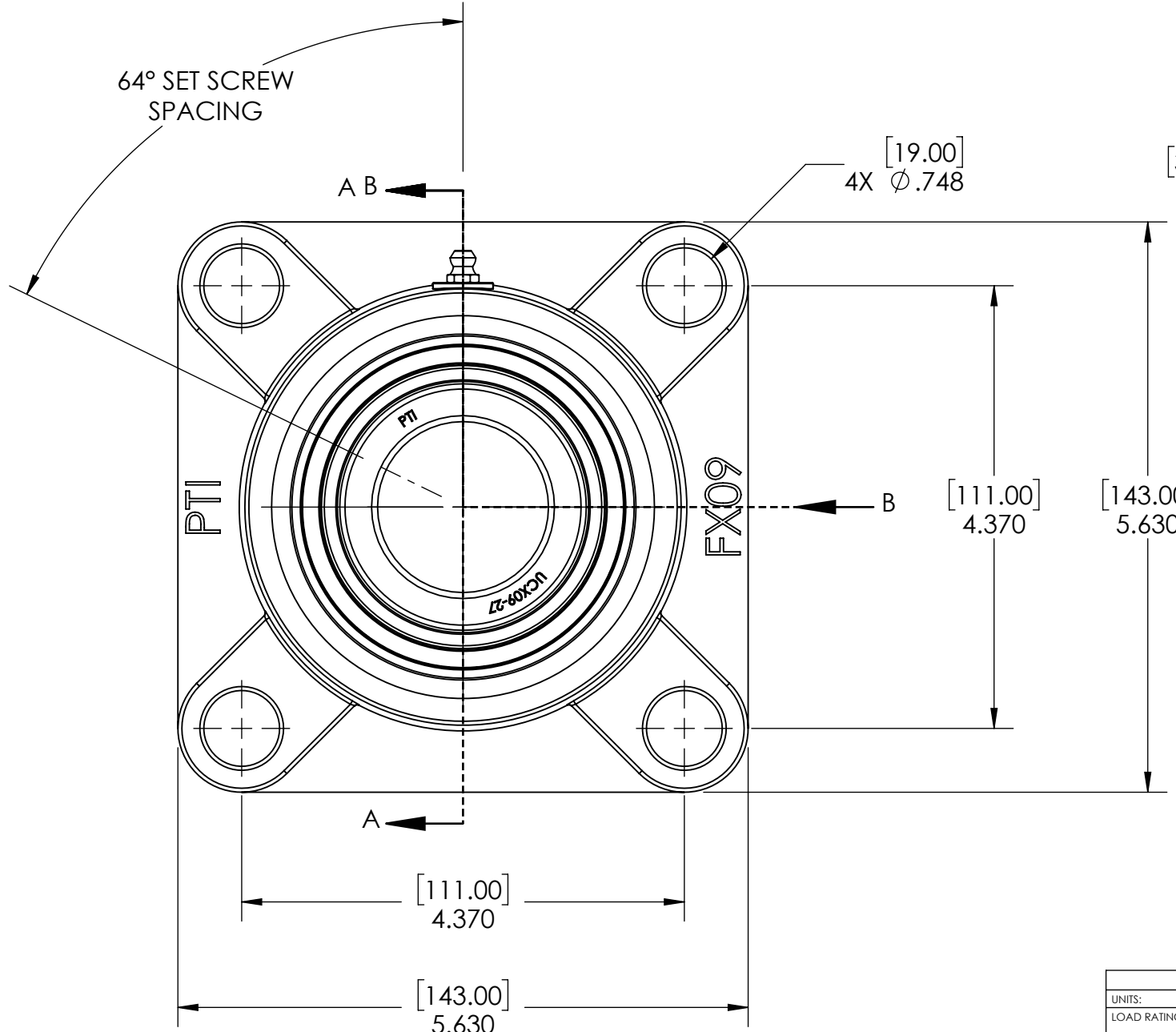
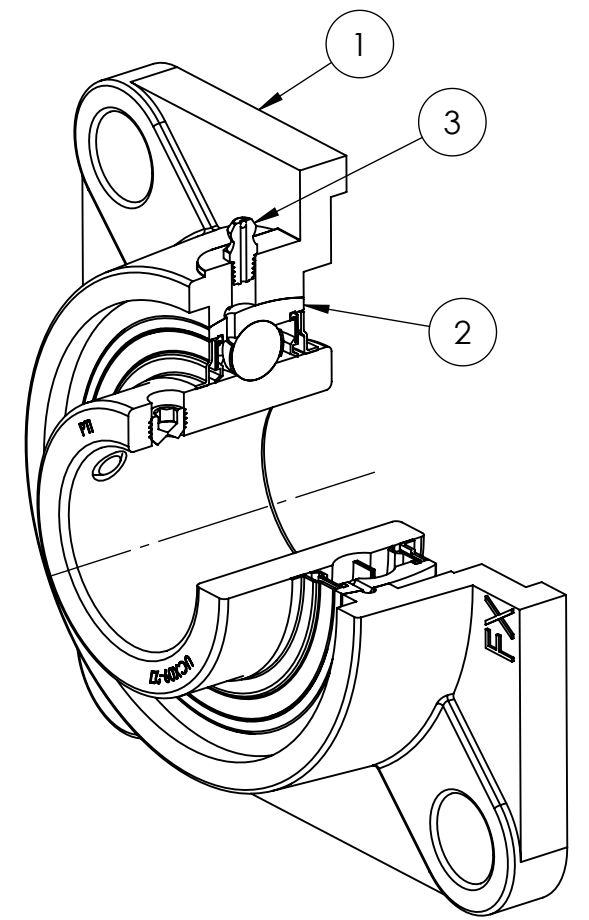
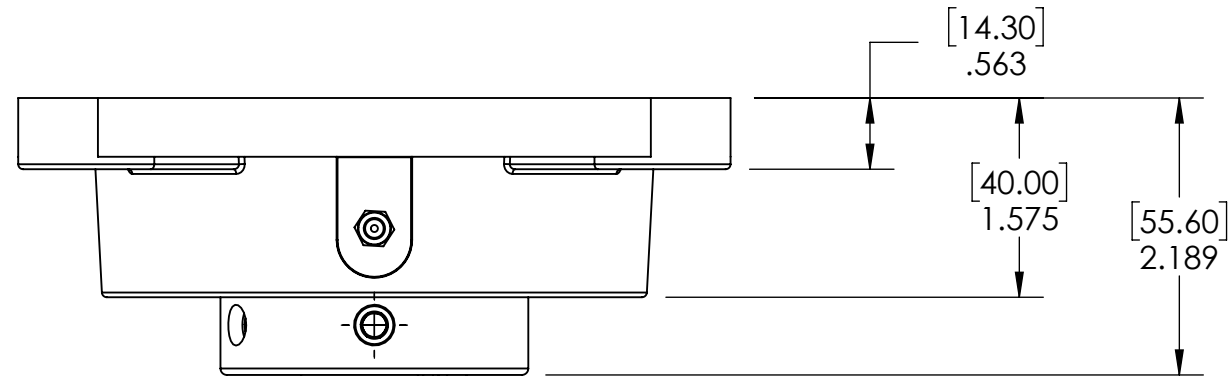

ITEM NO.	PART NUMBER	MATERIAL	COATING	QTY.
3	M6 ZERK	STAINLESS STEEL	N/A	1
2	UCX09-27	BEARING STEEL	N/A	1
1	FX09	STAINLESS STEEL	POWDER COAT	1

SPECIFICATIONS		SOLVE INDUSTRIAL MOTION GROUP		WEIGHT	
UNITS:	IN (mm)	SIZE	B	MATERIAL	5.37 LBS
LOAD RATINGS	C: 7,900 LBS Co: 5,200 LBS	DWG. NO.		COATING	SEE BOM
SPEED RATING	3400 RPM	DATE		DRAWN	SEC 01/03/2025
GREASE TYPE	NLGI #2	CHECKED	KODS	APPROVED	01/06/2025
GREASE FILL	40%	THIRD ANGLE PROJECTION			
OPERATING TEMP	10°F - 200°F	PROPRIETARY AND CONFIDENTIAL			
SEAL TYPE	B-TYPE	THE INFORMATION CONTAINED IN THIS DRAWING IS THE SOLE PROPERTY OF SOLVE IMG. ANY REPRODUCTION IN PART OR AS A WHOLE WITHOUT THE WRITTEN PERMISSION OF SOLVE IMG IS PROHIBITED.			
INTERNAL CLEARANCE	C3	ITEM DESCRIPTION: UCX09-27			
TORQUE SETTING ON SET SCREWS		SCALE 1:8			

DATE	BY	REVISION DESCRIPTION	REV

9 8 7 6 5 4 3 2 1

A B C D E F G