

9 8 7 6 5 4 3 2 1

G F E D C B A

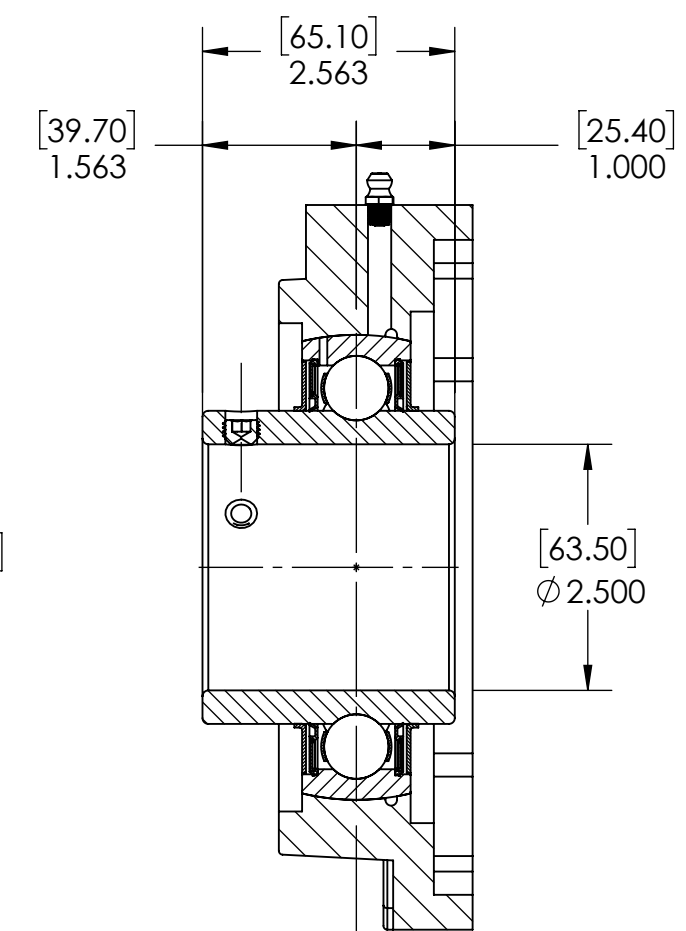
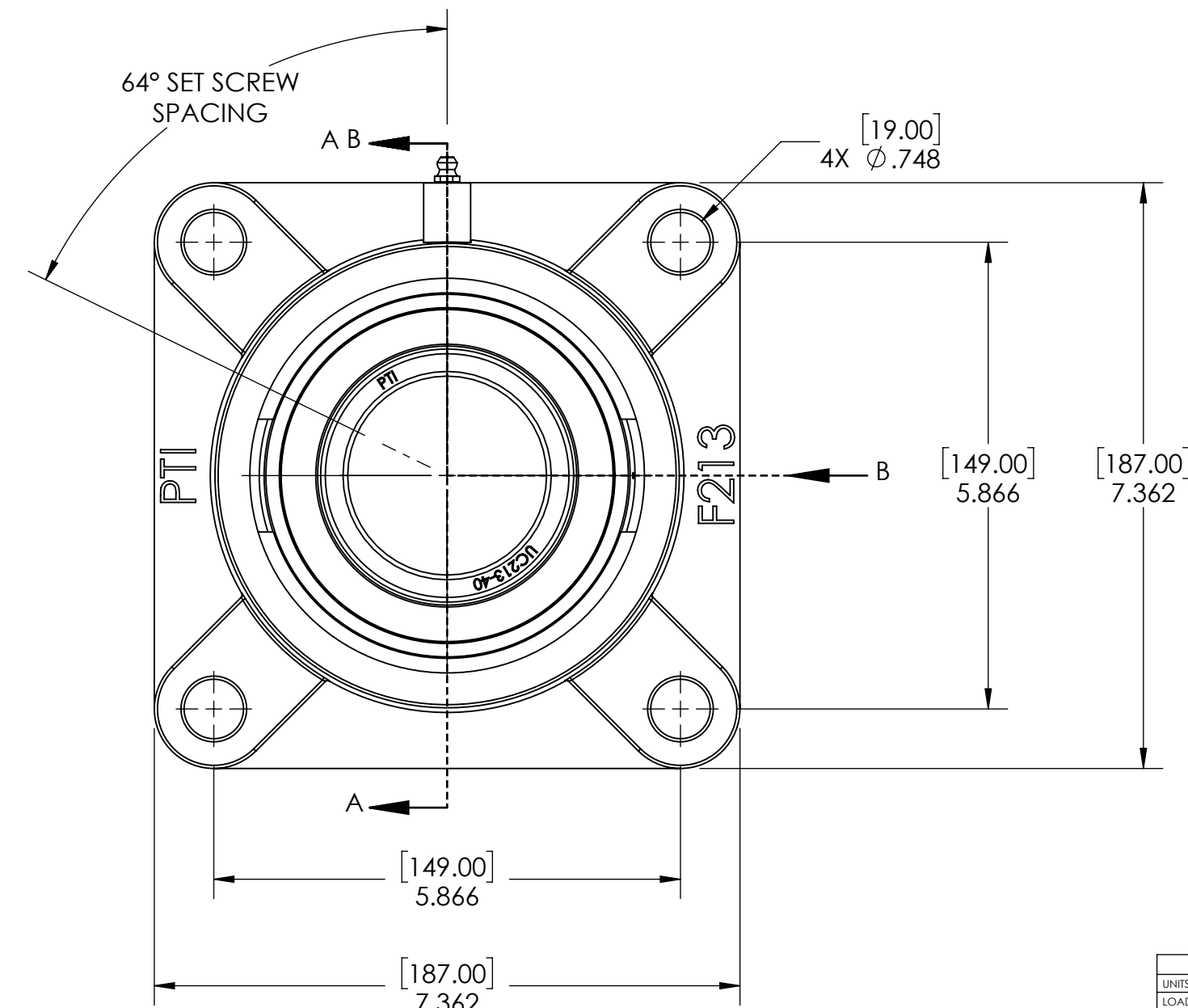
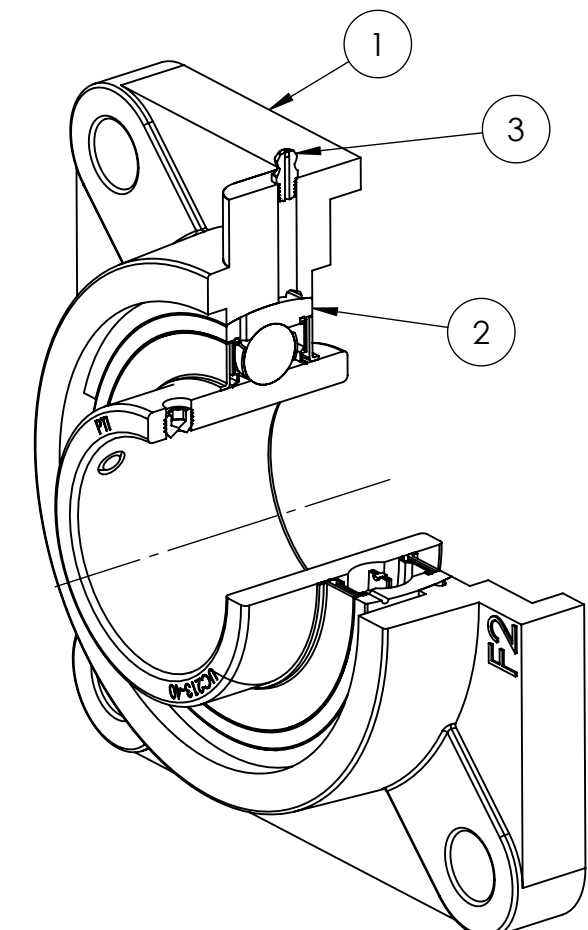
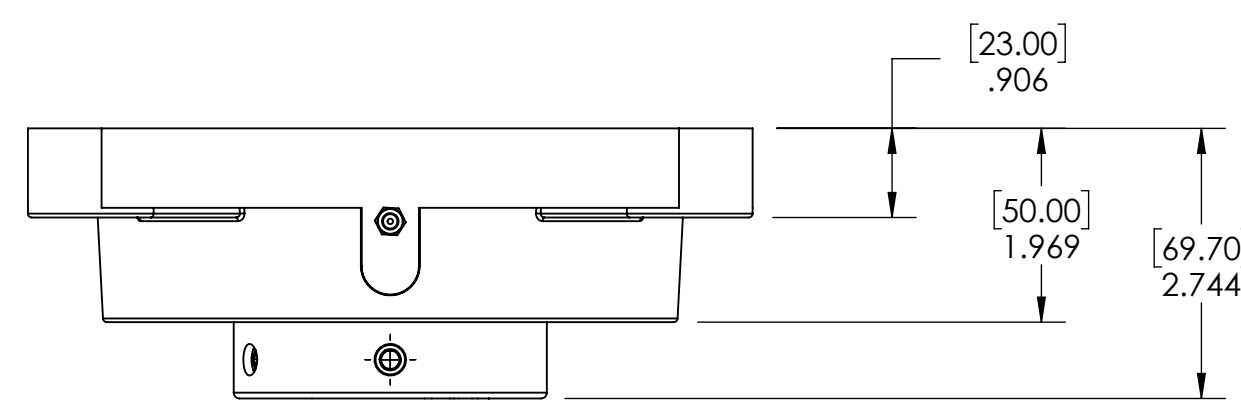

SECTION VIEW A-A

3	M6 ZERK	STEEL	ZINC PLATED	1
2	UC213-40	BEARING STEEL	N/A	1
1	F213	CAST IRON	POWDER COAT	1
ITEM NO.	PART NUMBER	MATERIAL	COATING	QTY.

SPECIFICATIONS		WEIGHT	
UNITS:	IN [mm]		11.76 LBS
LOAD RATINGS	C: 13,800 LBS Co: 9,890 LBS	MATERIAL	SEE BOM
		COATING	SEE BOM
SPEED RATING	2600 RPM	DRAWN	SEC 01/03/2025
GREASE TYPE	NLGI #2	CHECKED	SEC 01/09/2025
GREASE FILL	40%	APPROVED	
OPERATING TEMP	10°F - 200°F	THIRD ANGLE PROJECTION	
SEAL TYPE	B-TYPE		
INTERNAL CLEARANCE	C3		
TORQUE SETTING ON SET SCREWS			



PROPRIETARY AND CONFIDENTIAL
THE INFORMATION CONTAINED IN THIS DRAWING IS THE SOLE PROPERTY OF SOLVE IMG. ANY REPRODUCTION IN PART OR AS A WHOLE WITHOUT THE WRITTEN PERMISSION OF SOLVE IMG IS PROHIBITED.

DATE	BY	REVISION DESCRIPTION	REV
ITEM DESCRIPTION: UCF213-40			SCALE 1:6
			REV -

9 8 7 6 5 4 3 2 1

A B C D E F G