

9 8 7 6 5 4 3 2 1

G F E D C B A

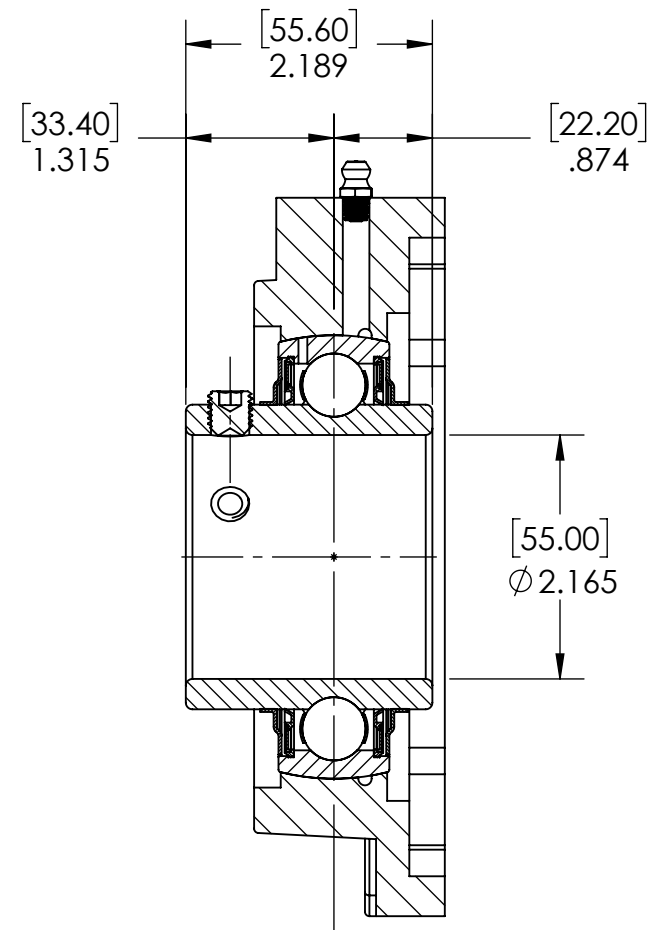
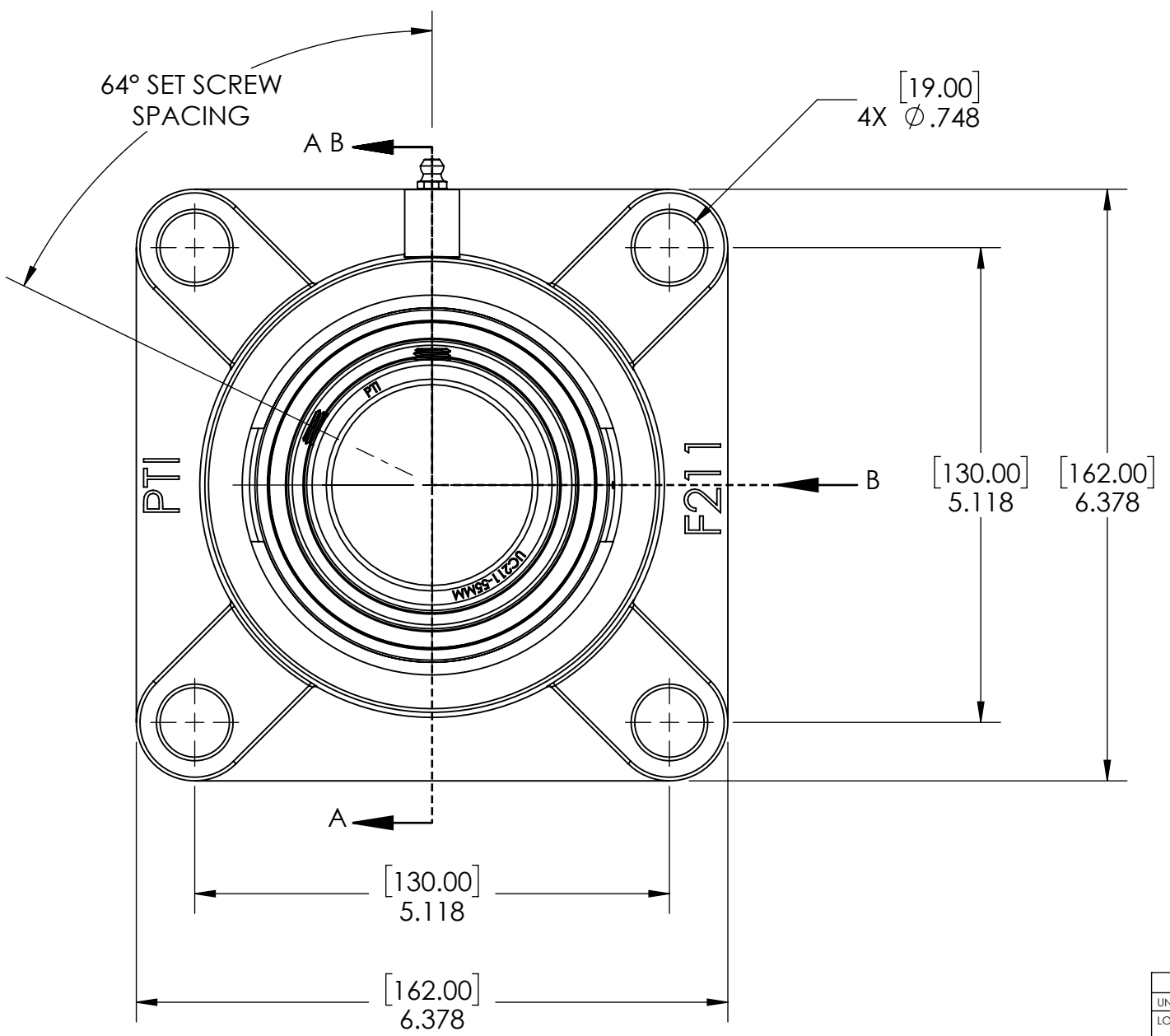
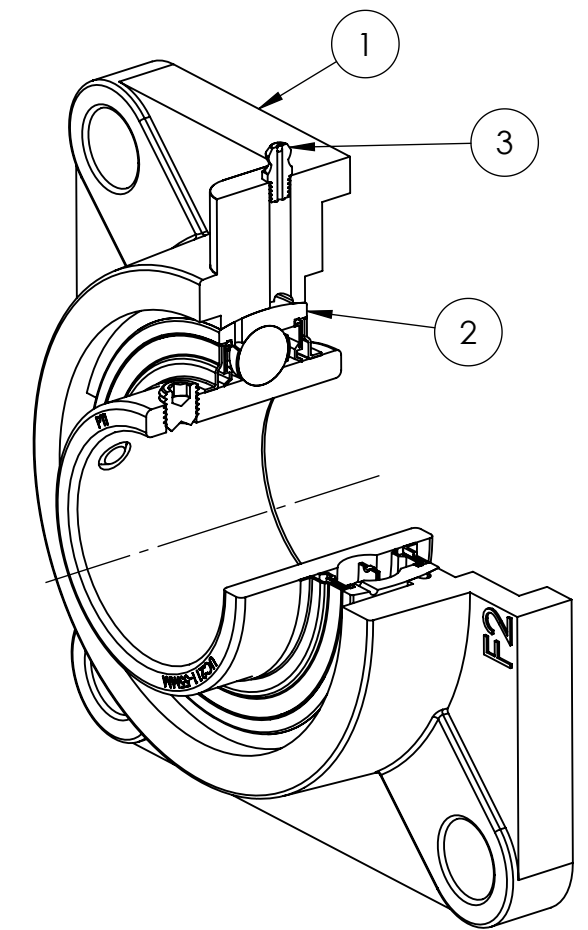
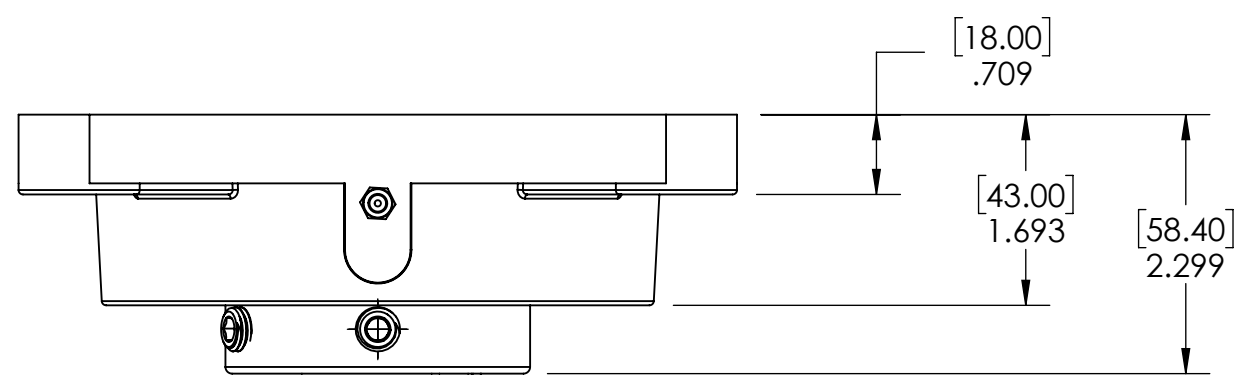

SECTION VIEW A-A

3	M6 ZERK	STEEL	ZINC PLATED	1
2	UC211-55MM	BEARING STEEL	N/A	1
1	F211	CAST IRON	POWDER COAT	1
ITEM NO.	PART NUMBER	MATERIAL	COATING	QTY.

SPECIFICATIONS		SOLVE INDUSTRIAL MOTION GROUP		WEIGHT	7.06 LBS
UNITS:	IN (mm)	SIZE	B	MATERIAL	SEE BOM
LOAD RATINGS	C: 9,780 LBS Co: 6,580 LBS	DWG. NO.		COATING	SEE BOM
SPEED RATING	3100 RPM	APPROVED		DRAWN	SEC 01/03/2025
GREASE TYPE	NLGI #2	CHECKED	SEC 01/09/2025	DATE	BY
GREASE FILL	40%	THIRD ANGLE PROJECTION		REVISION DESCRIPTION	
OPERATING TEMP	10°F - 200°F			ITEM DESCRIPTION:	
SEAL TYPE	B-TYPE			UCF211-55MM	
INTERNAL CLEARANCE	C3			SCALE	1:7
TORQUE SETTING ON SET SCREWS				REV	-

A B C D E F G

9 8 7 6 5 4 3 2 1