

9 8 7 6 5 4 3 2 1

G F E D C B A

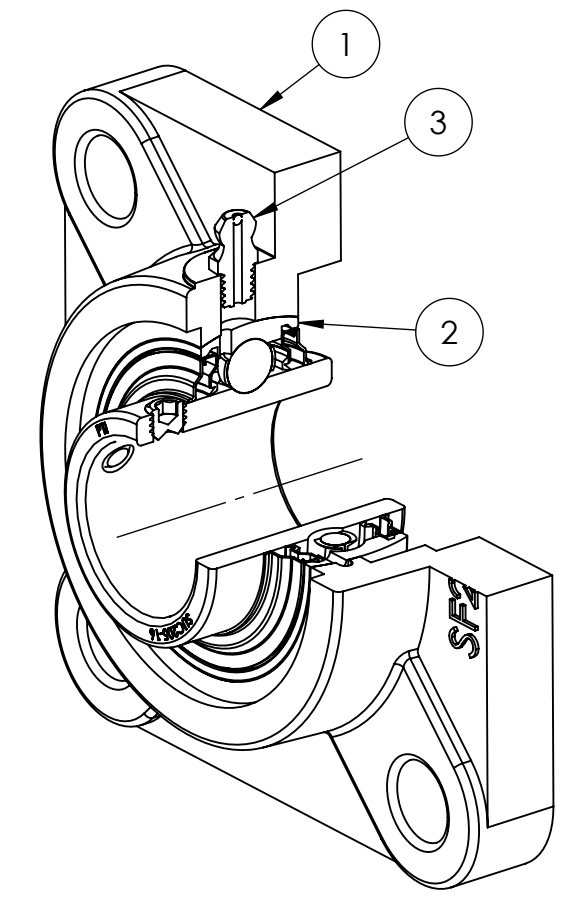
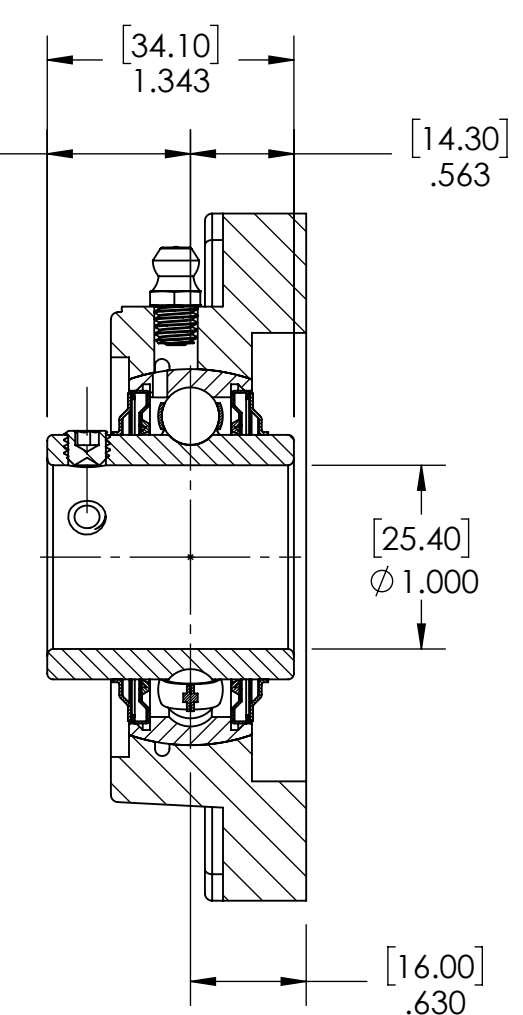
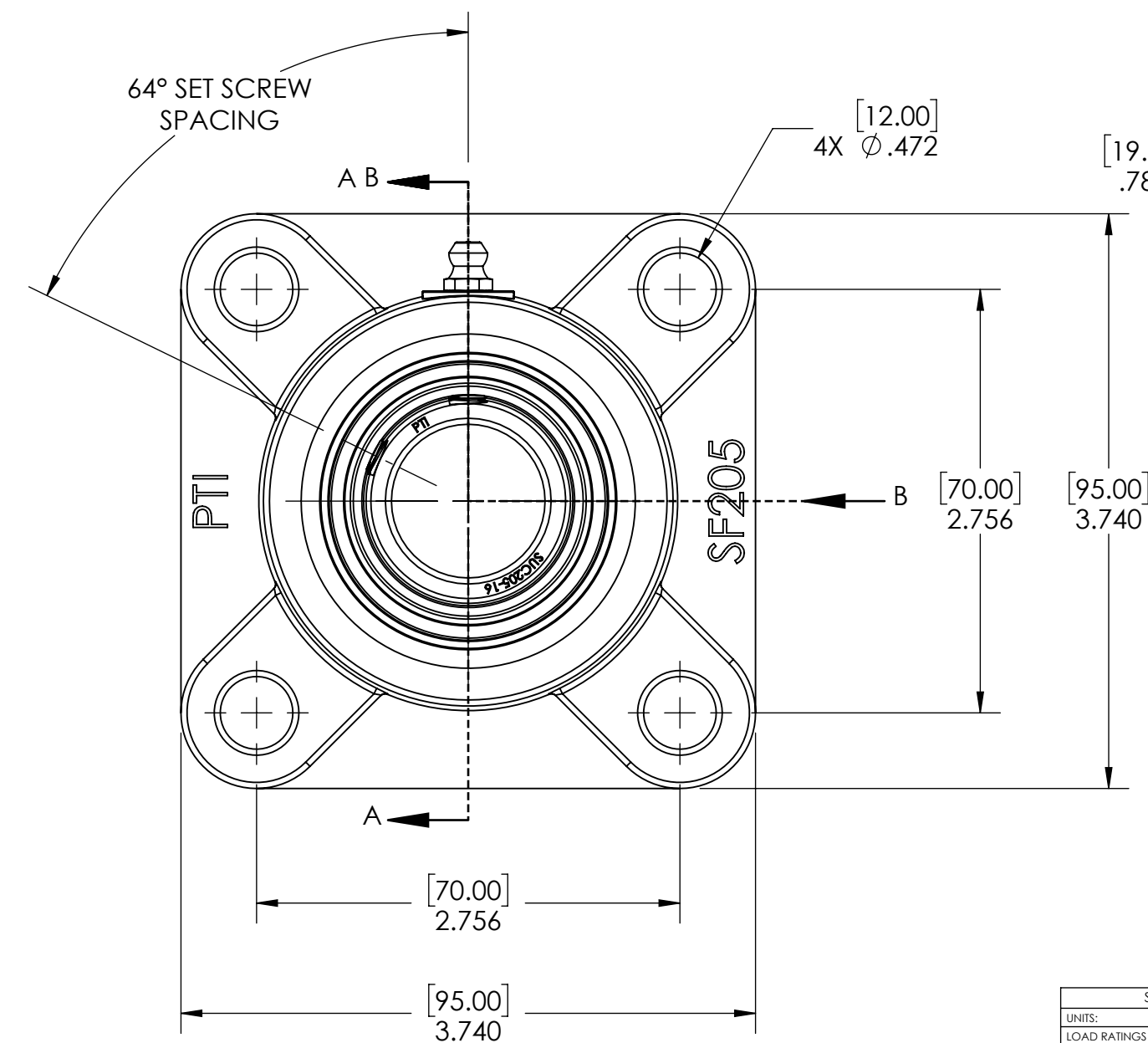
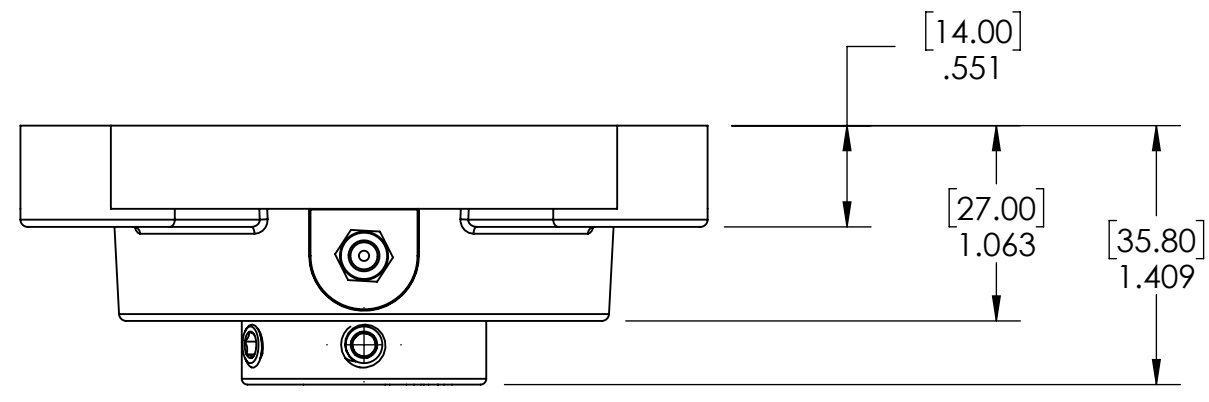

SECTION VIEW A-A

ITEM NO.	PART NUMBER	MATERIAL	COATING	QTY.
3	M6 ZERK	STAINLESS STEEL	N/A	1
2	SUC205-16	STAINLESS STEEL	N/A	1
1	SF205	STAINLESS STEEL	N/A	1

SPECIFICATIONS		WEIGHT	
UNITS:	IN (mm)		2.01 LBS
LOAD RATINGS	C: 2,600 LBS Co: 1,430 LBS	MATERIAL	SEE BOM
SPEED RATING	6250 RPM	COATING	SEE BOM
GREASE TYPE	FM222	DRAWN	SEC 01/03/2025
GREASE FILL	40%	CHECKED	AK 01/09/2025
OPERATING TEMP	-10°F - 250°F	APPROVED	
SEAL TYPE	K-TYPE	THIRD ANGLE PROJECTION	
INTERNAL CLEARANCE	C3		
TORQUE SETTING ON SET SCREWS			



PROPRIETARY AND CONFIDENTIAL
THE INFORMATION CONTAINED IN THIS DRAWING IS THE SOLE PROPERTY OF SOLVE IMG. ANY REPRODUCTION IN PART OR AS A WHOLE WITHOUT THE WRITTEN PERMISSION OF SOLVE IMG IS PROHIBITED.

DATE	BY	REVISION DESCRIPTION	REV
ITEM DESCRIPTION:			SCALE
SUCSF205-16			1:12
			REV
			-

9 8 7 6 5 4 3 2 1

A B C D E F G