

9 8 7 6 5 4 3 2 1

G F E D C B A

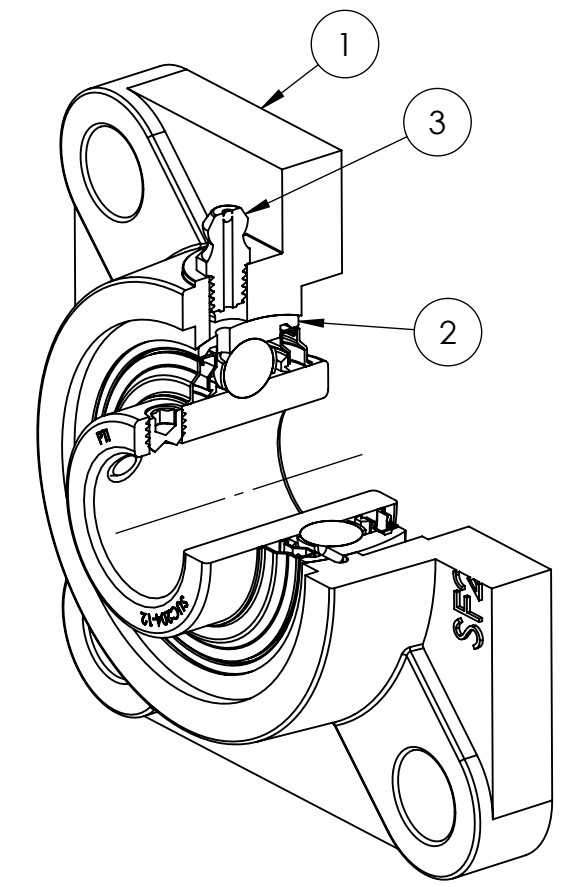
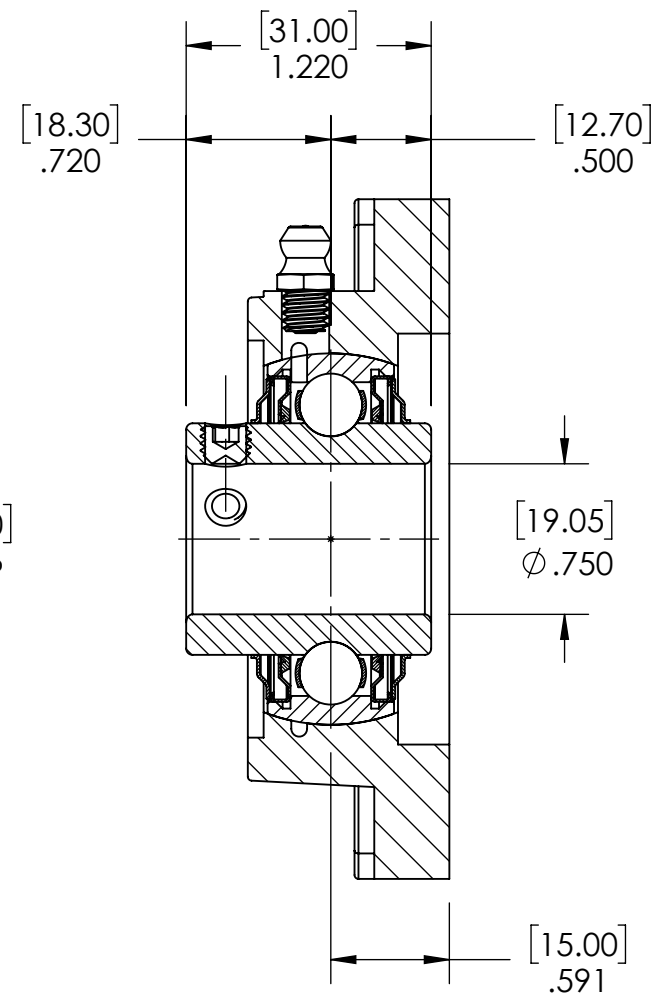
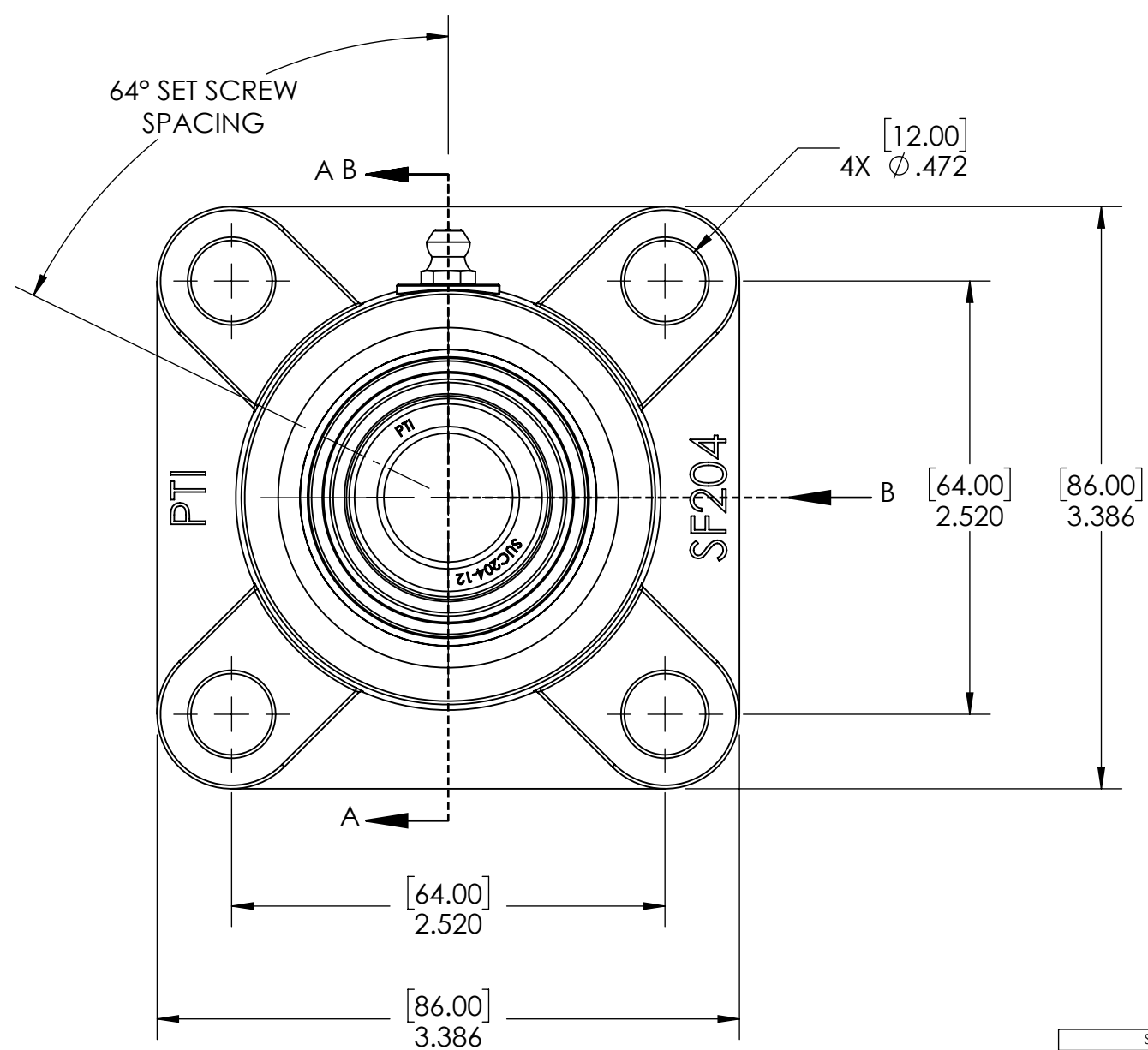
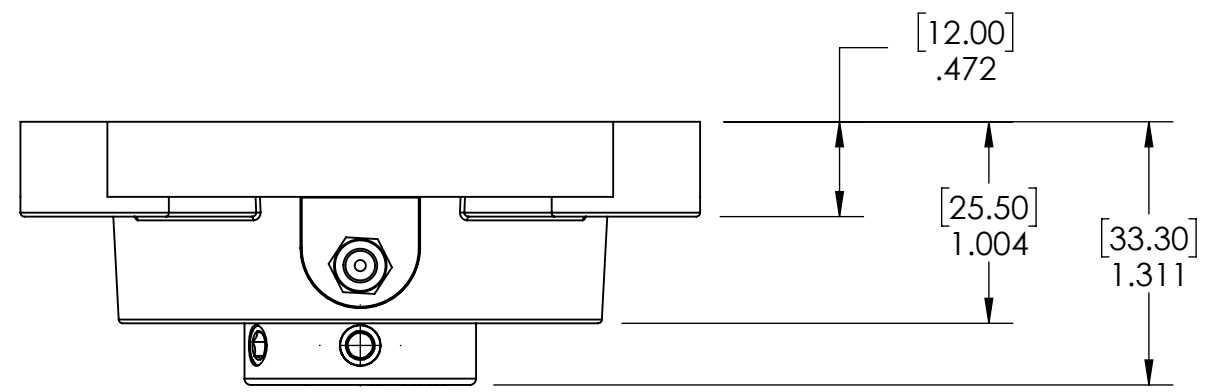

SECTION VIEW A-A

3	M6 ZERK	STAINLESS STEEL	N/A	1
2	SUC204-12	STAINLESS STEEL	N/A	1
1	SF204	STAINLESS STEEL	N/A	1
ITEM NO.	PART NUMBER	MATERIAL	COATING	QTY.

SPECIFICATIONS	
UNITS:	IN (mm)
LOAD RATINGS	C: 2,400 LBS Co: 1,180 LBS
SPEED RATING	7450 RPM
GREASE TYPE	FM222
GREASE FILL	40%
OPERATING TEMP	-10°F - 250°F
SEAL TYPE	K-TYPE
INTERNAL CLEARANCE	C3
TORQUE SETTING ON SET SCREWS	

**SOLVE**  
INDUSTRIAL MOTION GROUP

SIZE **PTI**

DWG. NO.

WEIGHT	1.55 LBS
MATERIAL	SEE BOM
COATING	SEE BOM
DRAWN	SEC 01/03/2025
CHECKED	AK 01/09/2025
APPROVED	
THIRD ANGLE PROJECTION	

DATE	BY	REVISION DESCRIPTION	REV
ITEM DESCRIPTION: SUCSF204-12			SCALE 1:13
			REV -

9 8 7 6 5 4 3 2 1

A B C D E F G