

9 8 7 6 5 4 3 2 1

G F E D C B A

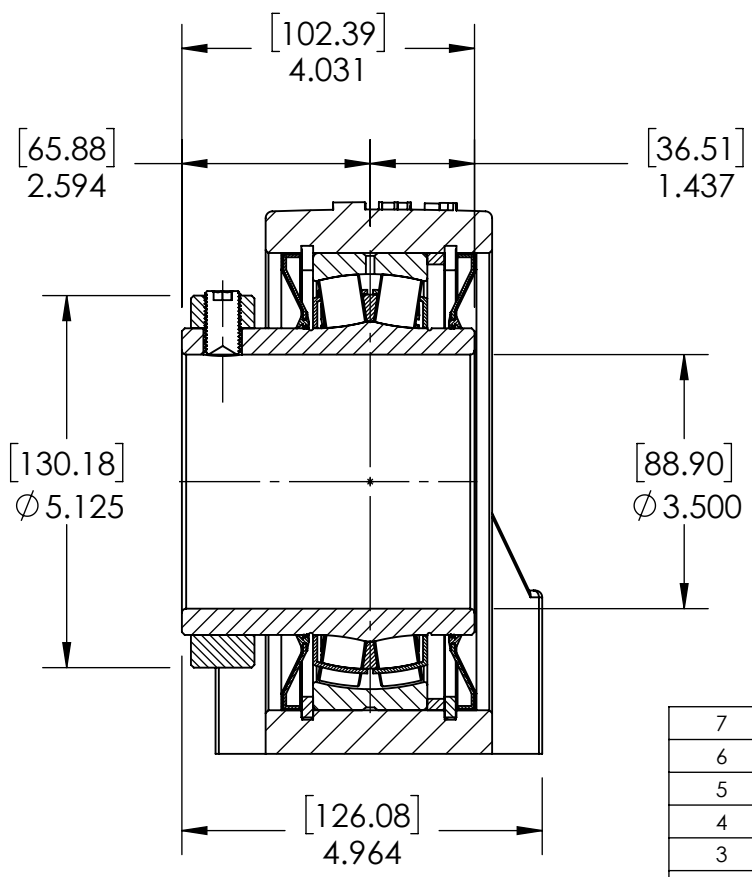
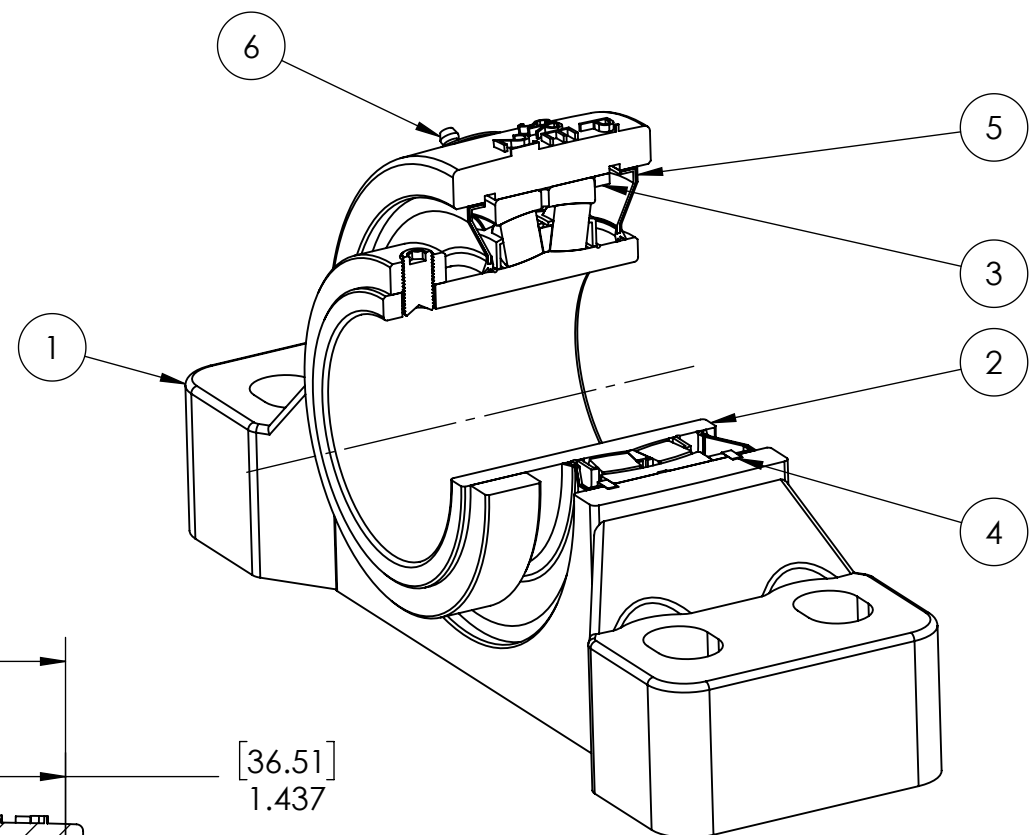
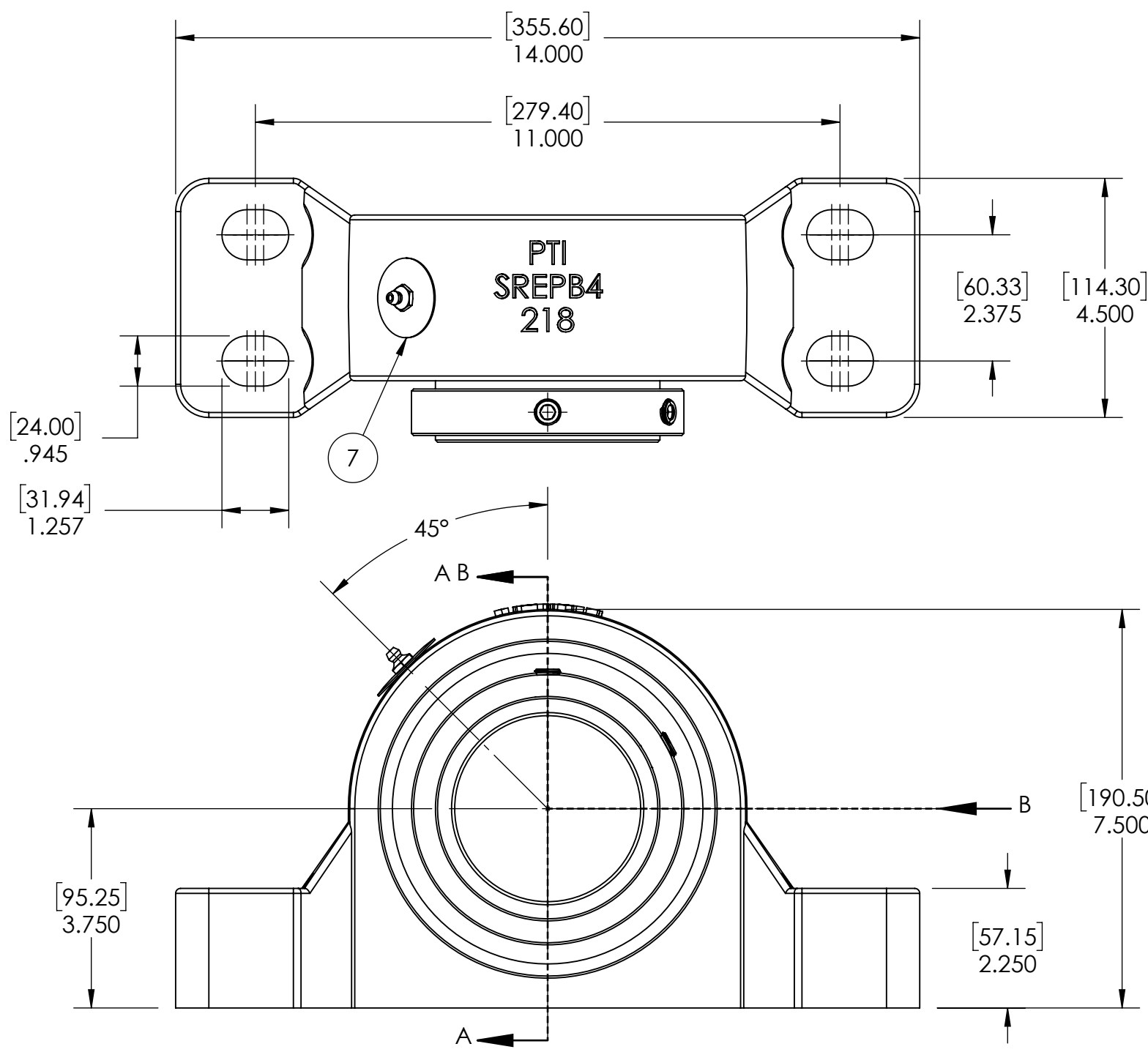

SECTION VIEW A-A

ITEM NO.	PART NUMBER	MATERIAL	COATING	QTY.
7	NP-SRE-NE	STEEL	N/A	1
6	1_8-27 ZERK	STEEL	ZINC PLATED	1
5	R3-476218	HNBR	N/A	2
4	OH160	STEEL	N/A	2
3	SR-FR160X6	STEEL	N/A	1
2	476218-308	BEARING STEEL	N/A	1
1	SREP4-218	DUCTILE IRON	POWDER COAT	1

SPECIFICATIONS	
UNITS	IN [mm]
LOAD RATINGS	C 62950 LBS Co 83180 LBS
SPEED RATING	1250 RPM
GREASE TYPE	NLGI #2
GREASE FILL	40-60%
OPERATING TEMP	-22°F - 290°F
SET SCREW SIZE	1/2-20UNF-7/8
SET SCREW TORQUE	620 IN-LBS
SET SCREW AXIAL RETENTION	900 LBS

SOLVE
INDUSTRIAL MOTION GROUP

PTI

DWG. NO.

WEIGHT	40.97 LBS
MATERIAL	SEE BOM
COATING	SEE BOM
DRAWN	SEC 03/19/2025
CHECKED	FP 04/15/2025
APPROVED	
THIRD ANGLE PROJECTION	

DATE	BY	REVISION DESCRIPTION	REV
ITEM DESCRIPTION: SRE-PB4-308R3NE			SCALE 1:8
			REV -

9 8 7 6 5 4 3 2 1

A B C D E F G