

9 8 7 6 5 4 3 2 1

G
F
E
D
C
B
A

G
F
E
D
C
B
A

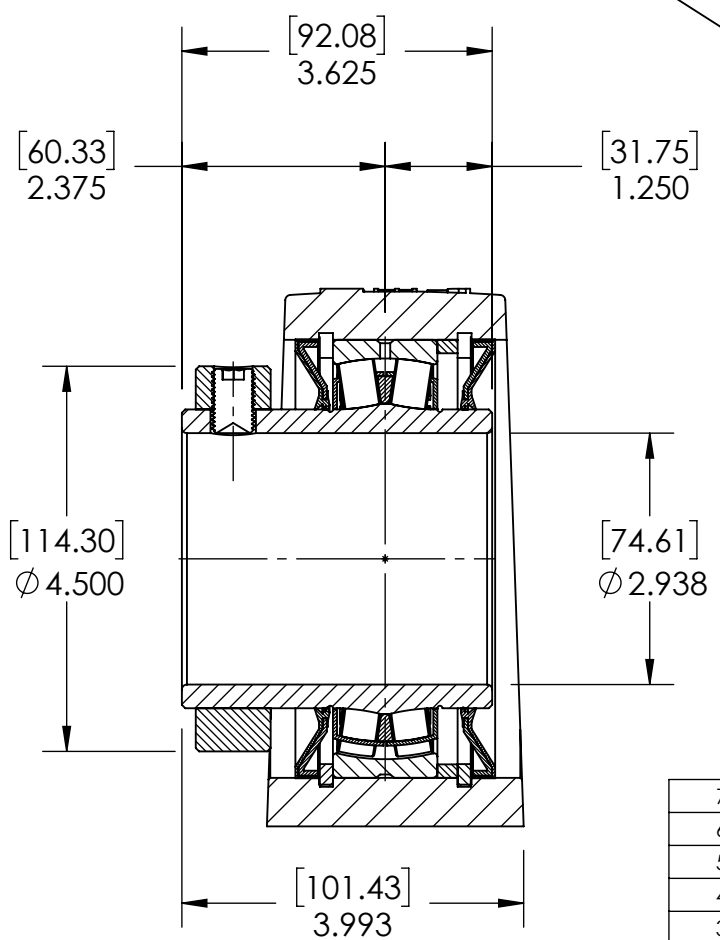
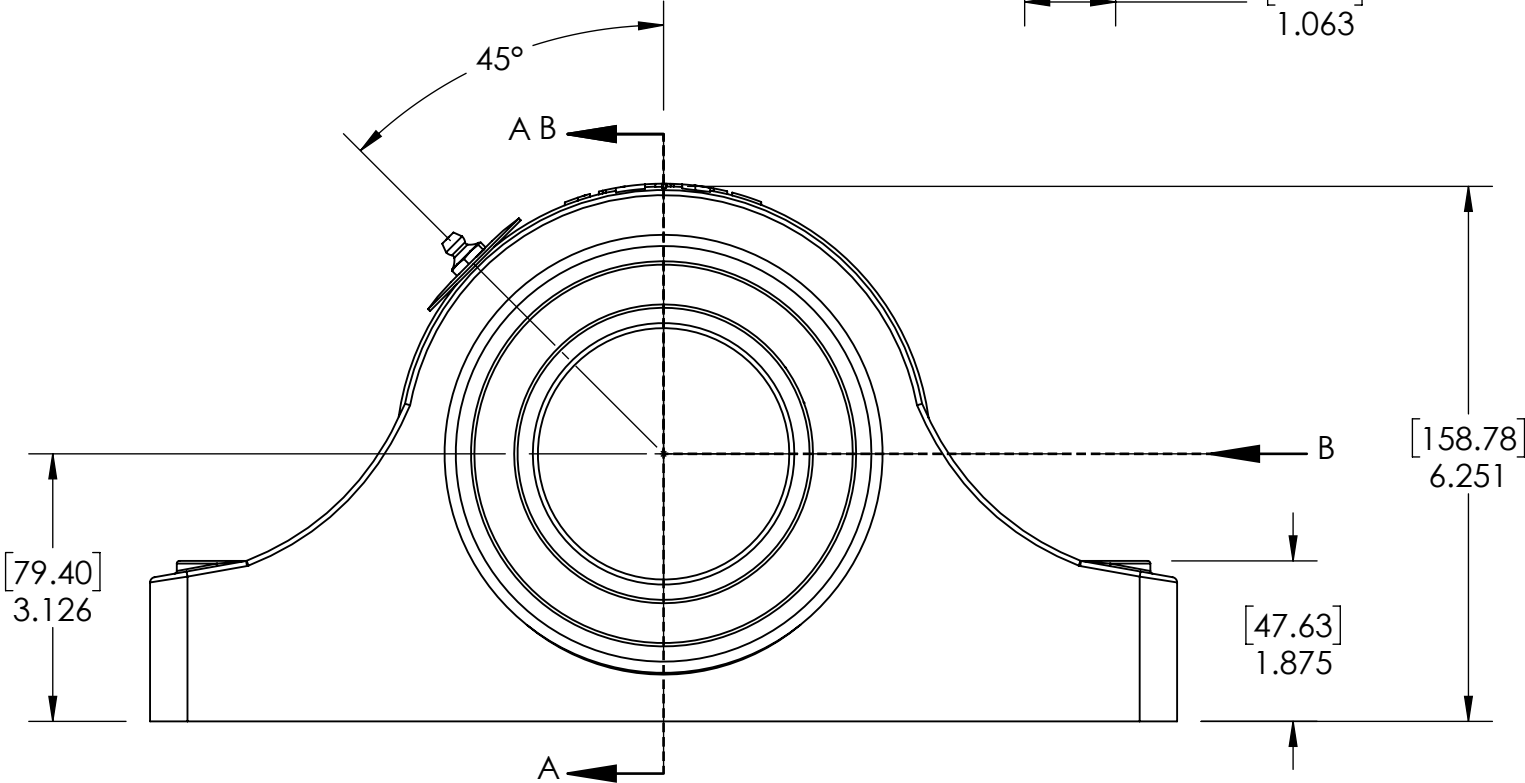
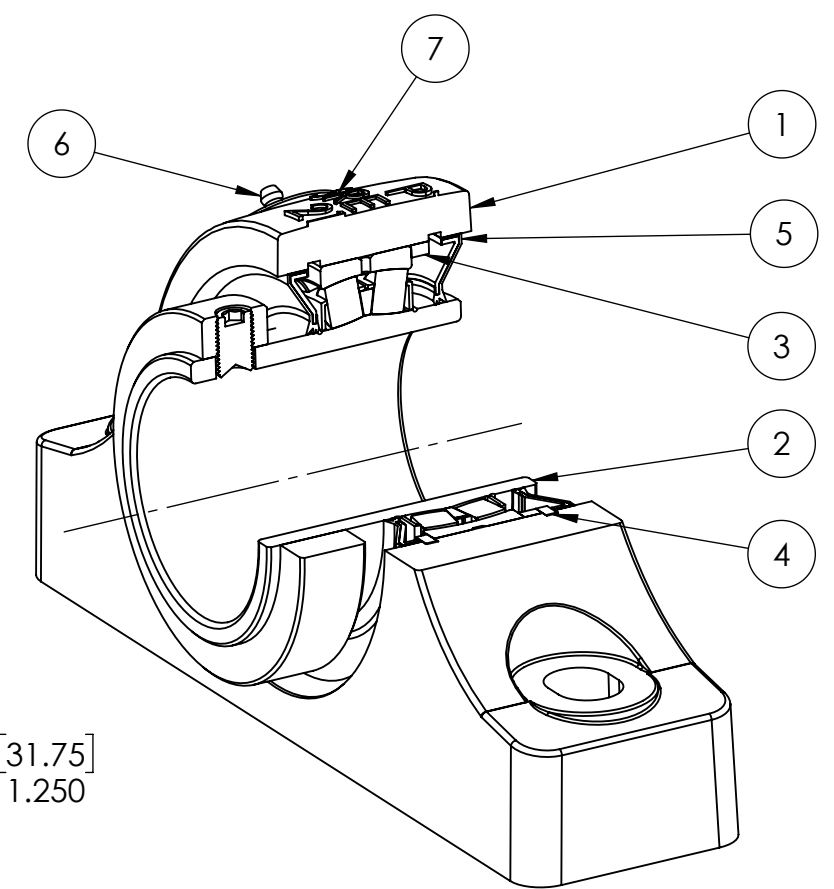
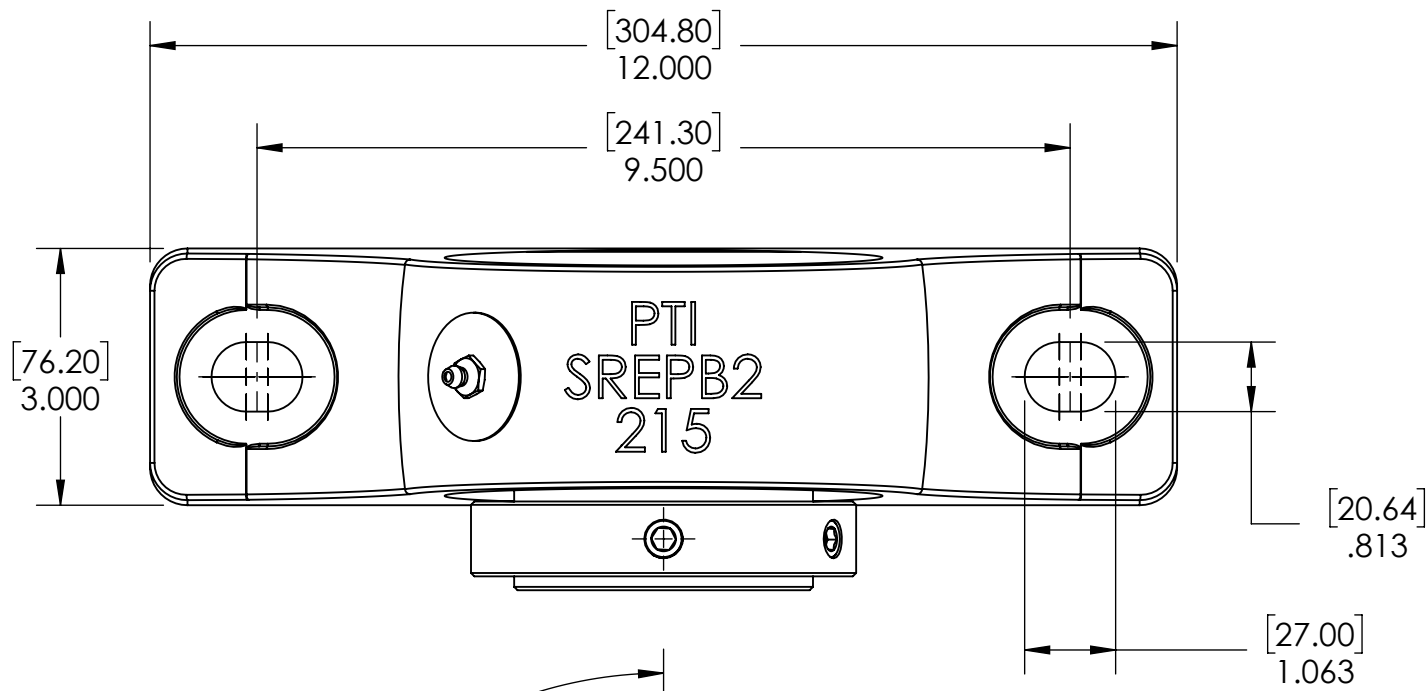

SECTION VIEW A-A

| ITEM NO. | PART NUMBER | MATERIAL | COATING | QTY. |
|----------|-------------|---------------|-------------|------|
| 7 | NP-SRE-NE | STEEL | N/A | 1 |
| 6 | 1_8-27 ZERK | STEEL | ZINC PLATED | 1 |
| 5 | R3-476215 | HNBR | N/A | 2 |
| 4 | OH130 | STEEL | N/A | 2 |
| 3 | SR-FR130X6 | STEEL | N/A | 1 |
| 2 | 476215-215 | BEARING STEEL | N/A | 1 |
| 1 | SREP2-215 | DUCTILE IRON | POWDER COAT | 1 |

| SPECIFICATIONS | |
|---------------------------|-----------------------------|
| UNITS | IN [mm] |
| LOAD RATINGS | C 41590 LBS Co 52830 LBS |
| SPEED RATING | 1500 RPM |
| GREASE TYPE | NLGI #2 |
| GREASE FILL | 40-60% |
| OPERATING TEMP | -22°F - 290°F |
| SET SCREW SIZE | 1/2-20UNF-3/4 |
| SET SCREW TORQUE | 620 IN-LBS |
| SET SCREW AXIAL RETENTION | 900 LBS |

SOLVE INDUSTRIAL MOTION GROUP
PTI
 DWG. NO.

| | |
|----------|----------------|
| WEIGHT | 26.34 LBS |
| MATERIAL | SEE BOM |
| COATING | SEE BOM |
| DRAWN | SEC 03/17/2025 |
| CHECKED | FP 04/16/2025 |
| APPROVED | |

| DATE | BY | REVISION DESCRIPTION | REV |
|-----------------------------------|----|----------------------|-----------|
| ITEM DESCRIPTION: SRE-PB2-215R3NE | | | SCALE 1:9 |
| | | | REV - |

9 8 7 6 5 4 3 2 1