

SECTION VIEW A-A

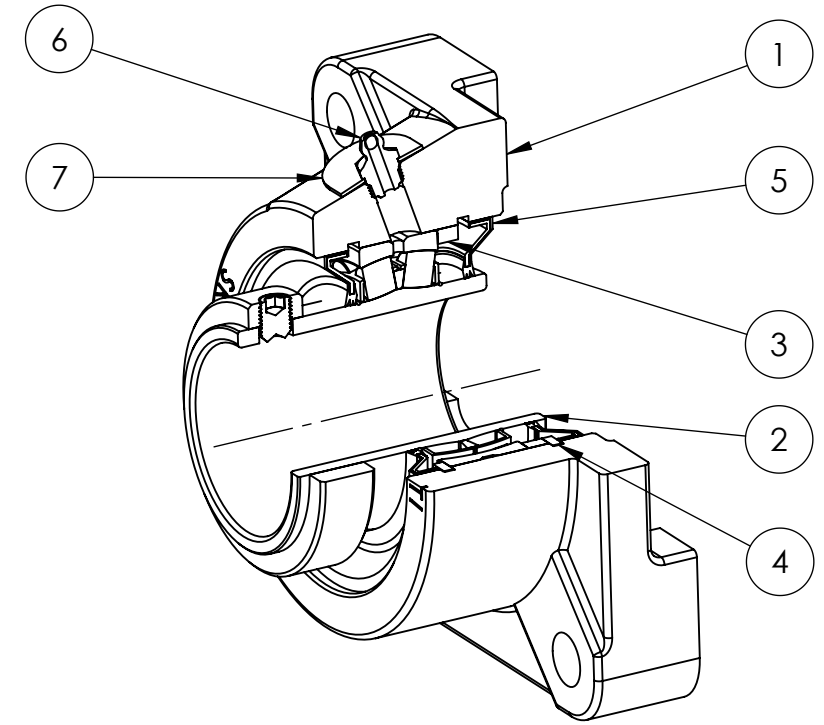

ITEM NO.	PART NUMBER	MATERIAL	COATING	QTY.
7	NPS-SRE-NE	STEEL	N/A	1
6	1_8-27 ZERK	STEEL	ZINC PLATED	1
5	R3-476210	HNBR	N/A	2
4	OH90	STEEL	N/A	2
3	SR-FR90X6	STEEL	N/A	1
2	476210-200	BEARING STEEL	N/A	1
1	SREFB4-210	DUCTILE IRON	POWDER COAT	1

SPECIFICATIONS	
UNITS	IN [mm]
LOAD RATINGS	C 20230 LBS Co 24730 LBS
SPEED RATING	2225 RPM
GREASE TYPE	NLGI #2
GREASE FILL	40-60%
OPERATING TEMP	-22°F - 290°F
SET SCREW SIZE	3/8-24UNF-1/2
SET SCREW TORQUE	250 IN-LBS
SET SCREW AXIAL RETENTION	515 LBS



WEIGHT	9.91 LBS
MATERIAL	SEE BOM
COATING	SEE BOM
DRAWN	SEC 03/06/2025
CHECKED	FP 04/11/2025
APPROVED	
THIRD ANGLE PROJECTION	

DATE	BY	REVISION DESCRIPTION	REV
ITEM DESCRIPTION: SRE-FB4-200R3NE			SCALE 1:14
			REV -

9 8 7 6 5 4 3 2 1

9 8 7 6 5 4 3 2 1

G
F
E
D
C
B
A

G
F
E
D
C
B
A