

9 8 7 6 5 4 3 2 1

G F E D C B A

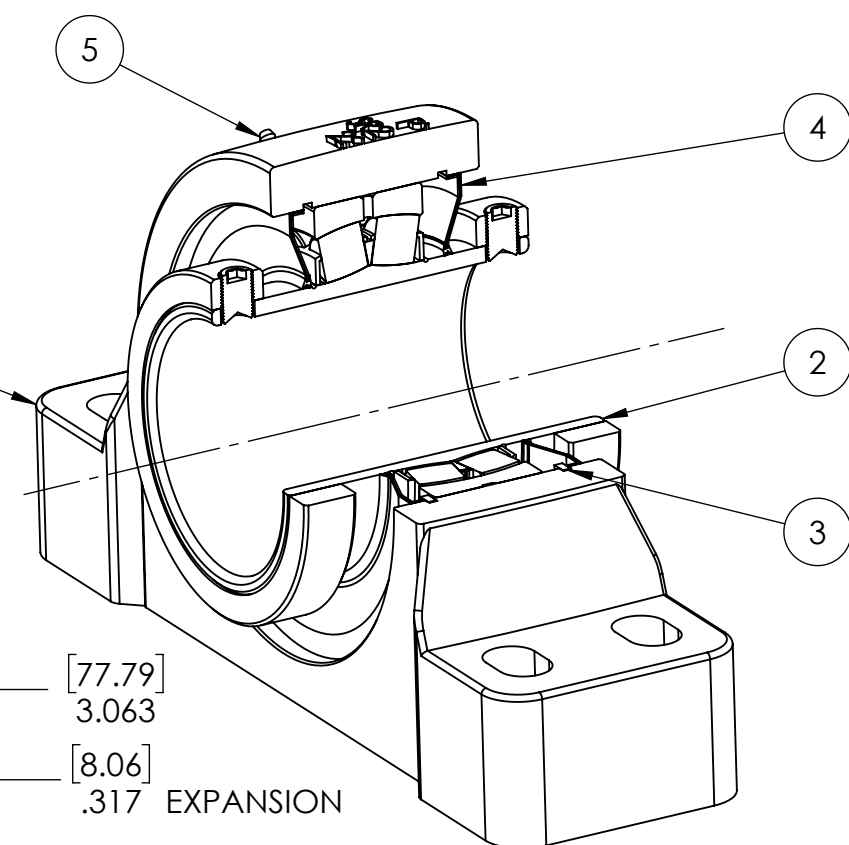
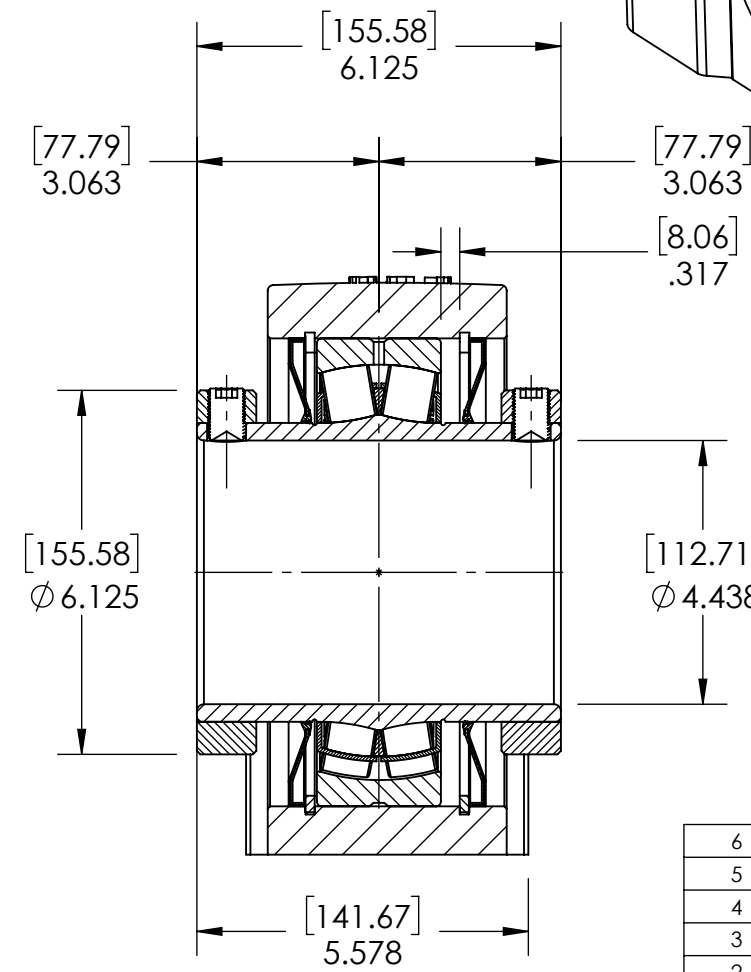
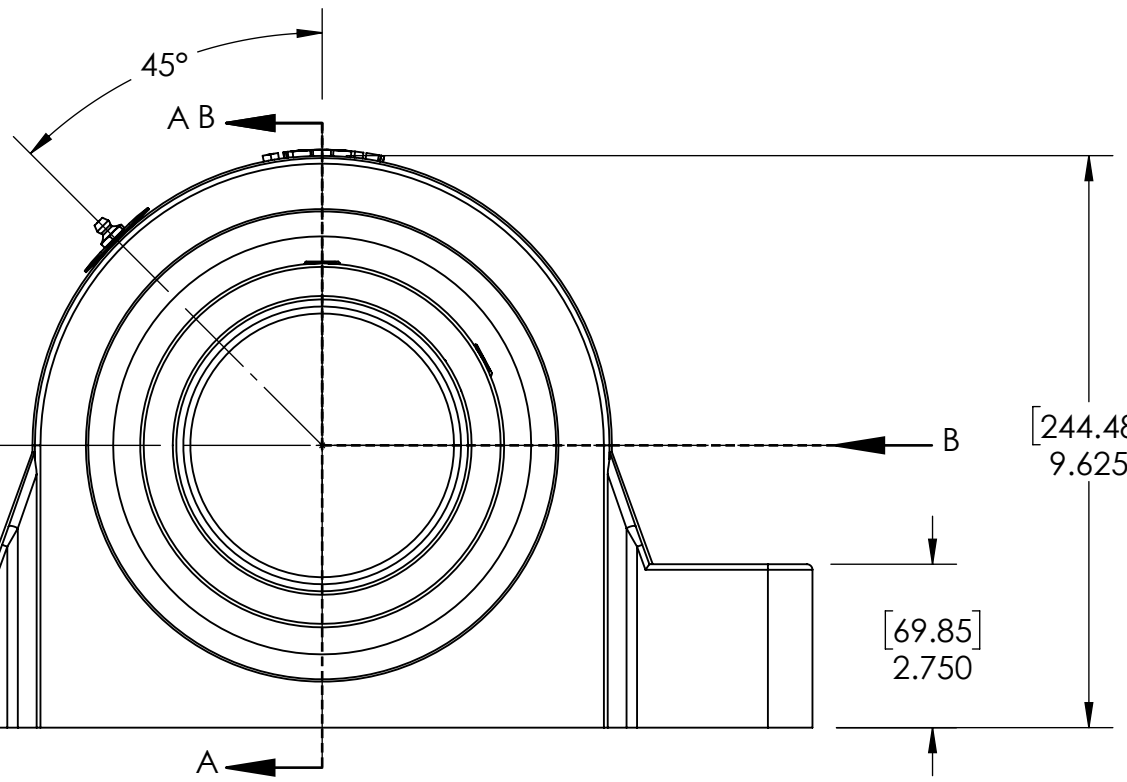
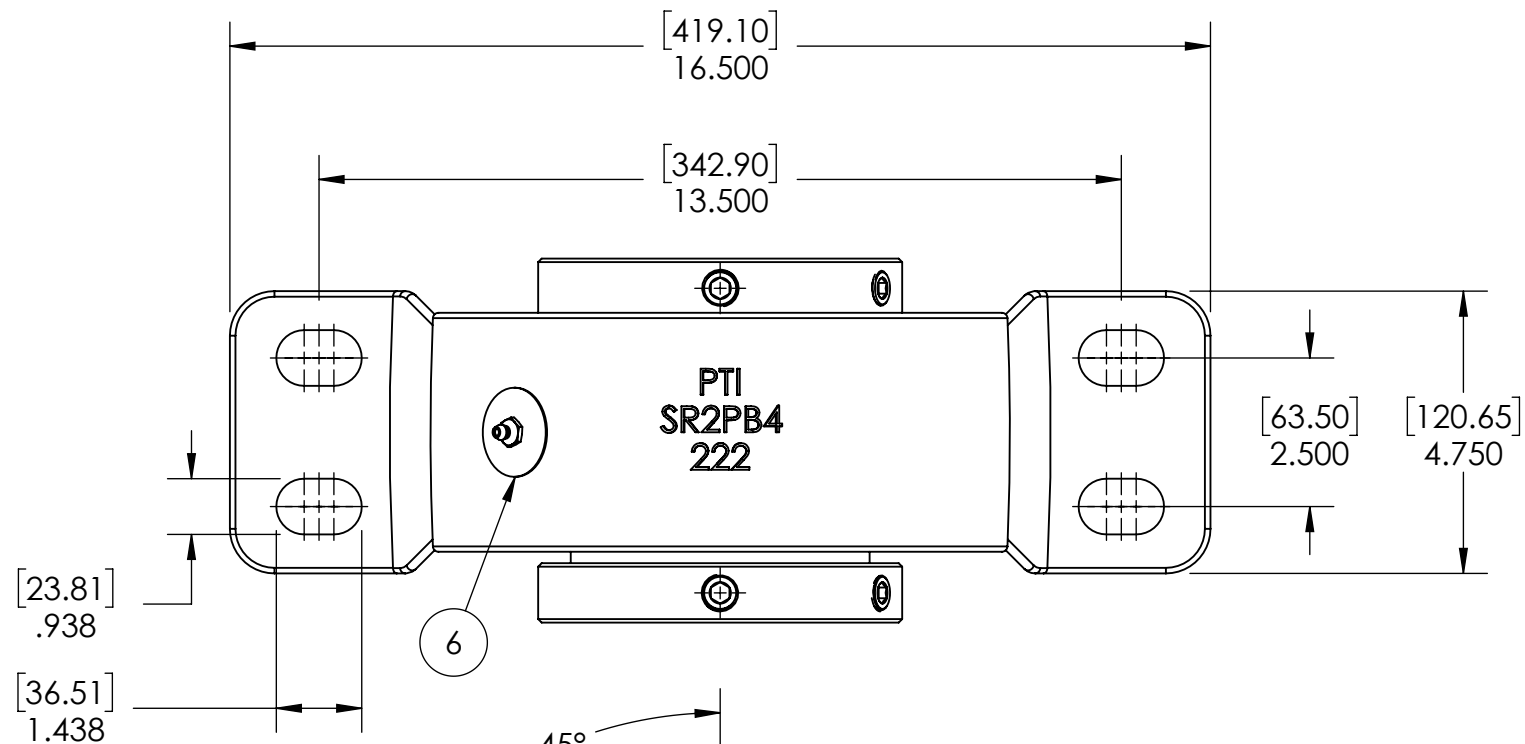

ITEM NO.	PART NUMBER	MATERIAL	COATING	QTY.
6	NP-SR2-EX	STEEL	N/A	1
5	1_8-27 ZERK	STEEL	ZINC PLATED	1
4	R3-476222	HNBR	N/A	2
3	OH200	STEEL	N/A	2
2	476222-407VSB	BEARING STEEL	N/A	1
1	SR2PB4-222	DUCTILE IRON	POWDER COAT	1

SPECIFICATIONS		SOLVE		WEIGHT	
UNITS	IN [mm]	INDUSTRIAL MOTION GROUP		81.66 LBS	
LOAD RATINGS	C 94420 LBS Co 134890LBS	PTI		MATERIAL SEE BOM	
SPEED RATING	1040 RPM	DWG. NO.		COATING SEE BOM	
GREASE TYPE	NLGI #2	PROPRIETARY AND CONFIDENTIAL		DRAWN SEC 03/19/2025	
GREASE FILL	40-60%	THE INFORMATION CONTAINED IN THIS DRAWING IS THE SOLE PROPERTY OF SOLVE IMG. ANY REPRODUCTION IN PART OR AS A WHOLE WITHOUT THE WRITTEN PERMISSION OF SOLVE IMG IS PROHIBITED.		CHECKED FP 04/15/2025	
OPERATING TEMP	-22°F - 290°F	THIRD ANGLE PROJECTION		APPROVED	
SET SCREW SIZE	5/8-18UNF-7/8	DATE		BY	
SET SCREW TORQUE	1325 IN-LBS	REVISION DESCRIPTION		REV	
SET SCREW AXIAL RETENTION	1200 LBS	ITEM DESCRIPTION:		SCALE	

DATE	BY	REVISION DESCRIPTION	REV
		SR2-PB4-407R3XP	1
			1:7
			-

9 8 7 6 5 4 3 2 1

A B C D E F G