

9 8 7 6 5 4 3 2 1

G F E D C B A

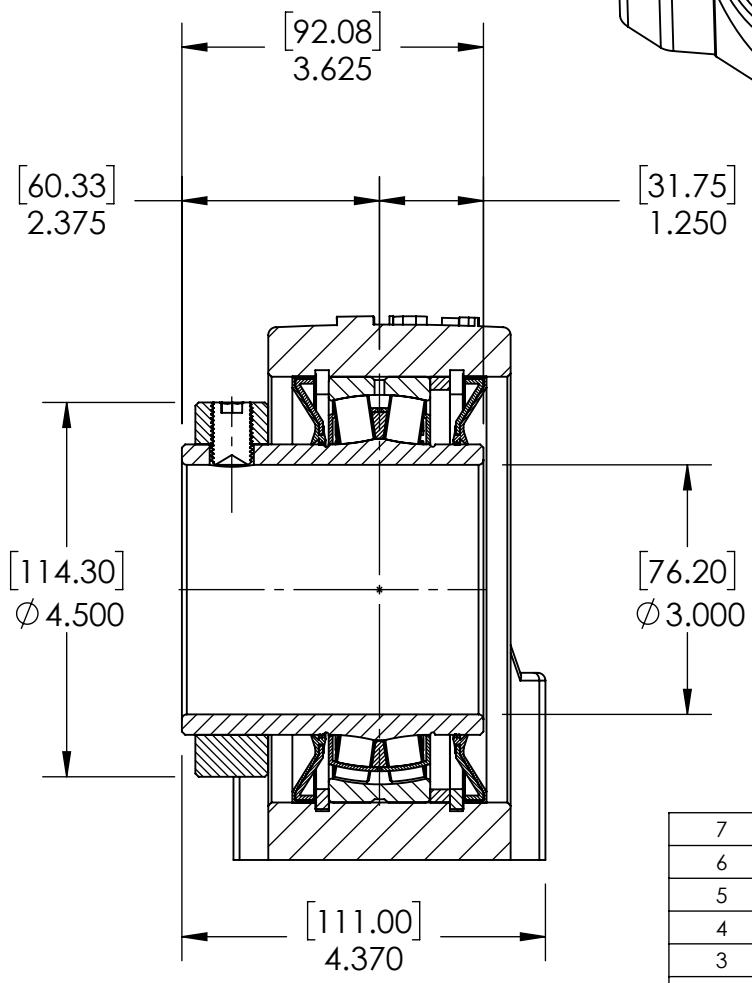
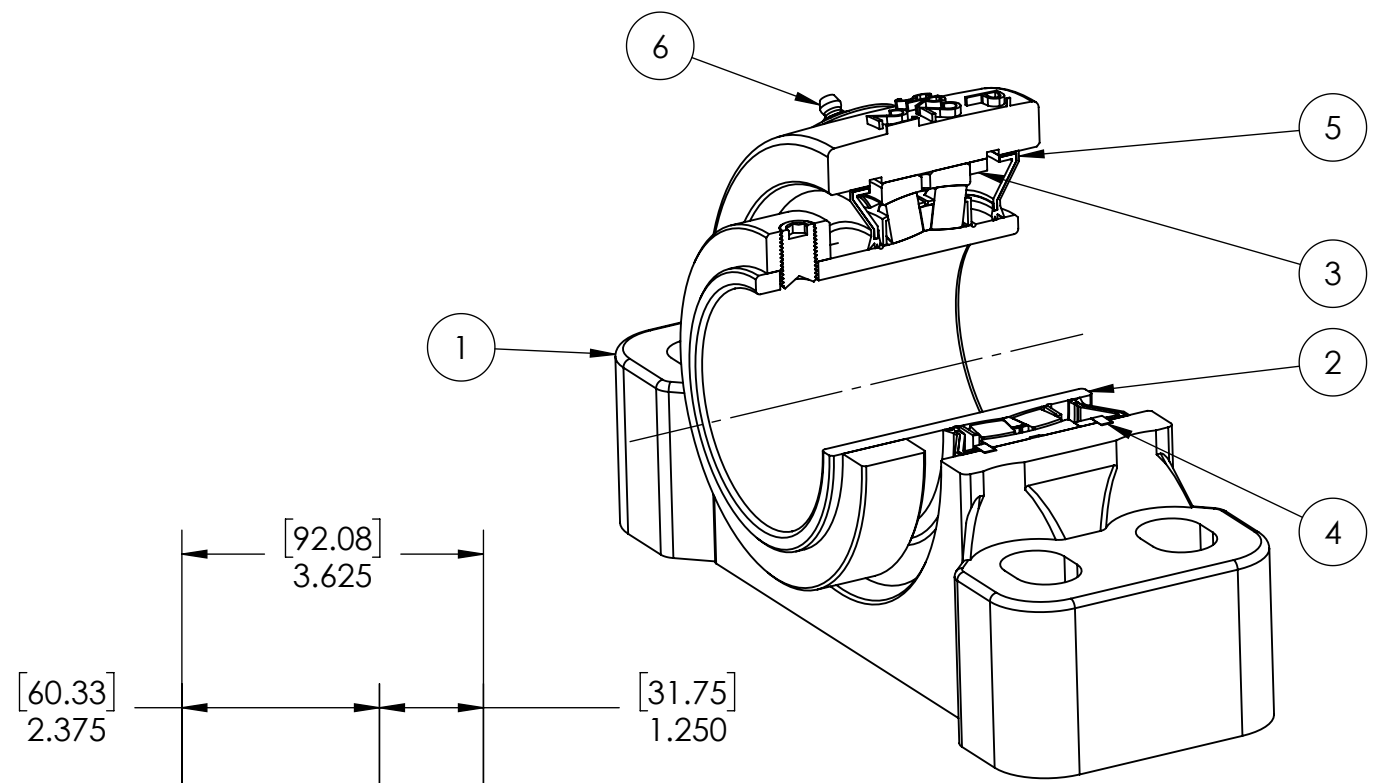
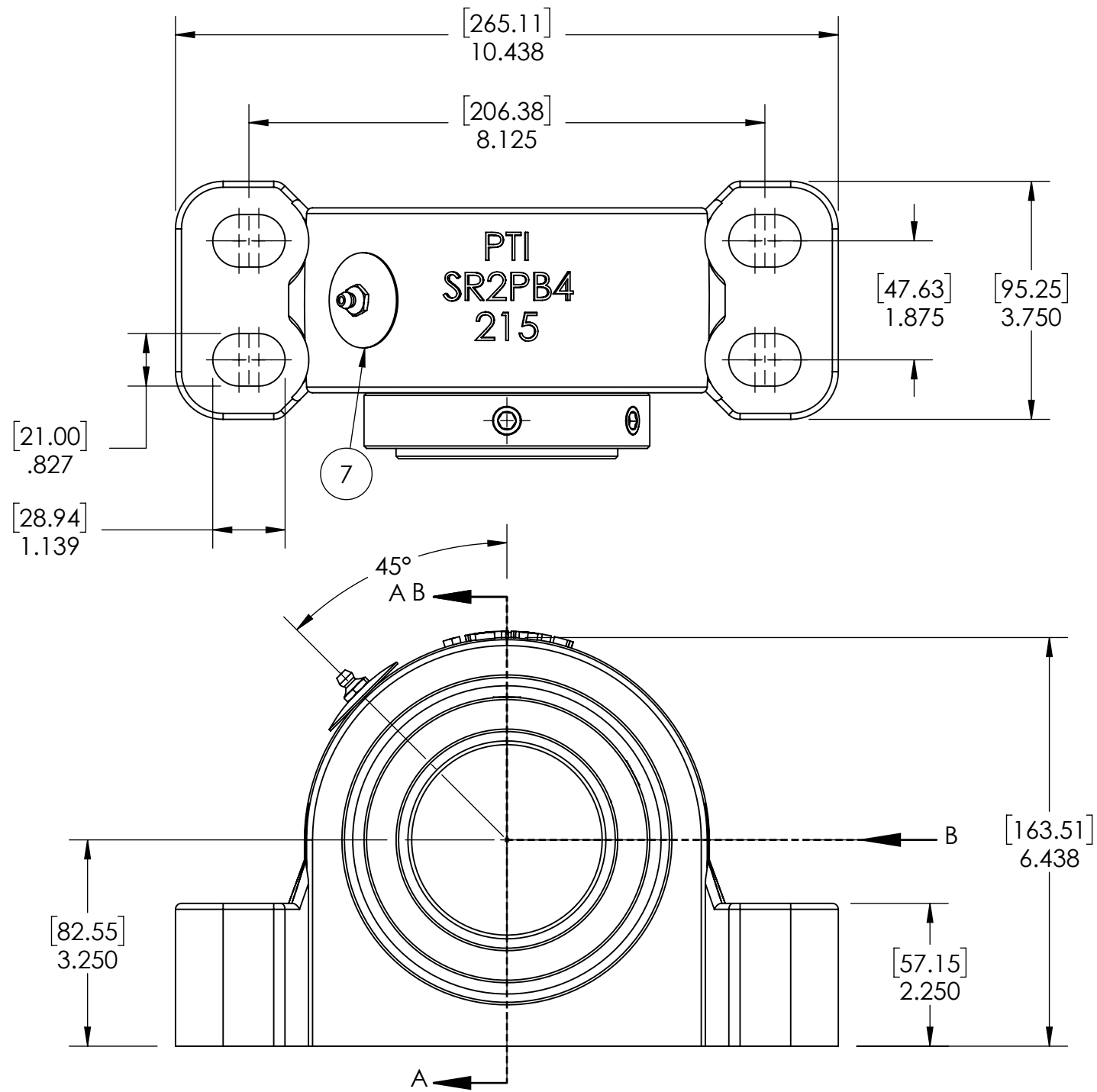

SECTION VIEW A-A

ITEM NO.	PART NUMBER	MATERIAL	COATING	QTY.
7	NP-SR2-NE	STEEL	N/A	1
6	1_8-27 ZERK	STEEL	ZINC PLATED	1
5	R3-476215	HNBR	N/A	2
4	OH130	STEEL	N/A	2
3	SR-FR130X6	STEEL	N/A	1
2	476215-300	BEARING STEEL	N/A	1
1	SR2PB4-215	DUCTILE IRON	POWDER COAT	1

SPECIFICATIONS		SOLVE INDUSTRIAL MOTION GROUP		WEIGHT	25.18 LBS		
UNITS	IN [mm]	B PTI		MATERIAL	SEE BOM		
LOAD RATINGS	C 41590 LBS Co 52830 LBS			COATING	SEE BOM		
SPEED RATING	1500 RPM	SIZE	B	DRAWN	SEC 03/19/2025		
GREASE TYPE	NLGI #2	DWG. NO.		CHECKED	FP 04/11/2025		
GREASE FILL	40-60%			APPROVED			
OPERATING TEMP	-22°F - 290°F	PROPRIETARY AND CONFIDENTIAL THE INFORMATION CONTAINED IN THIS DRAWING IS THE SOLE PROPERTY OF SOLVE IMG. ANY REPRODUCTION IN PART OR AS A WHOLE WITHOUT THE WRITTEN PERMISSION OF SOLVE IMG IS PROHIBITED.		DATE	BY	REVISION DESCRIPTION	REV
SET SCREW SIZE	1/2-20UNF-3/4			SR2-PB4-300R3NE		SCALE	1:10
SET SCREW TORQUE	620 IN-LBS			REV		-	
SET SCREW AXIAL RETENTION	900 LBS						

A B C D E F G

9 8 7 6 5 4 3 2 1