

9 8 7 6 5 4 3 2 1

G
F
E
D
C
B
A

G
F
E
D
C
B
A

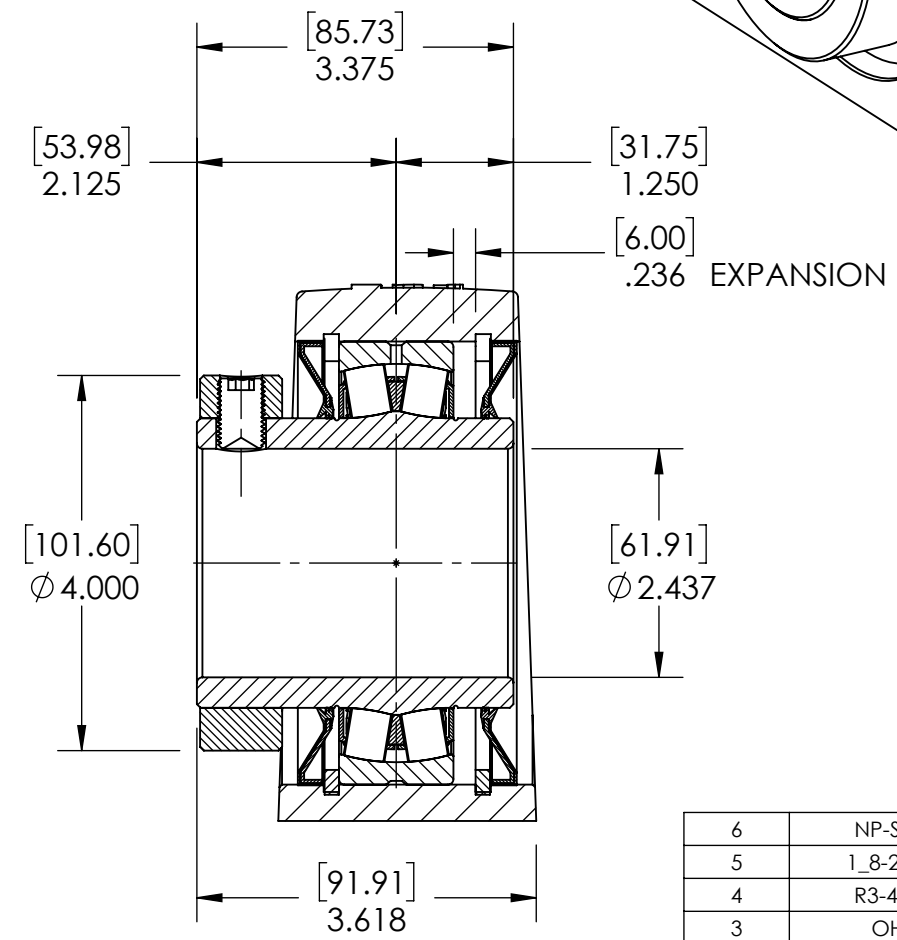
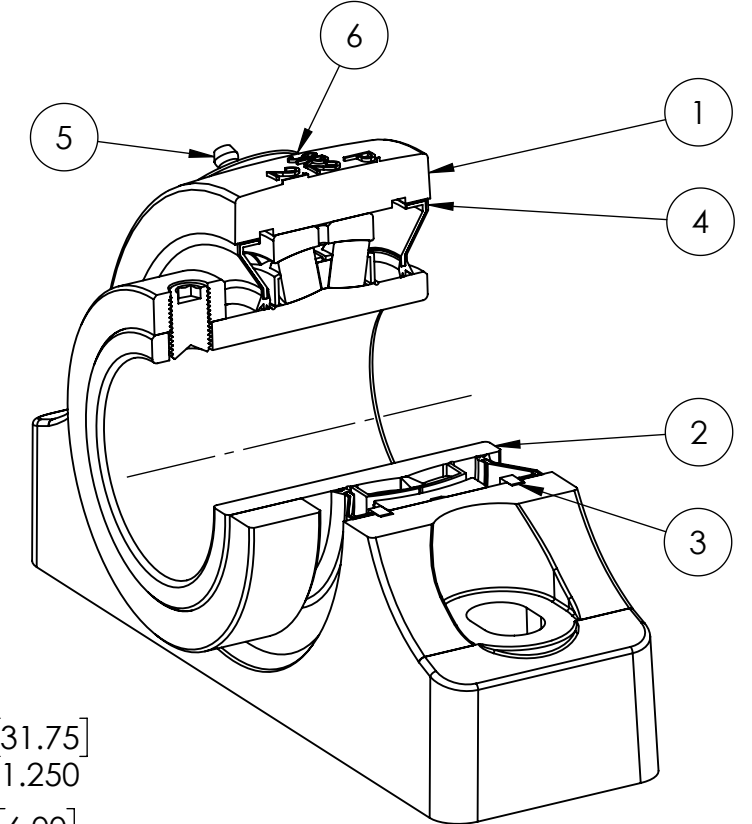
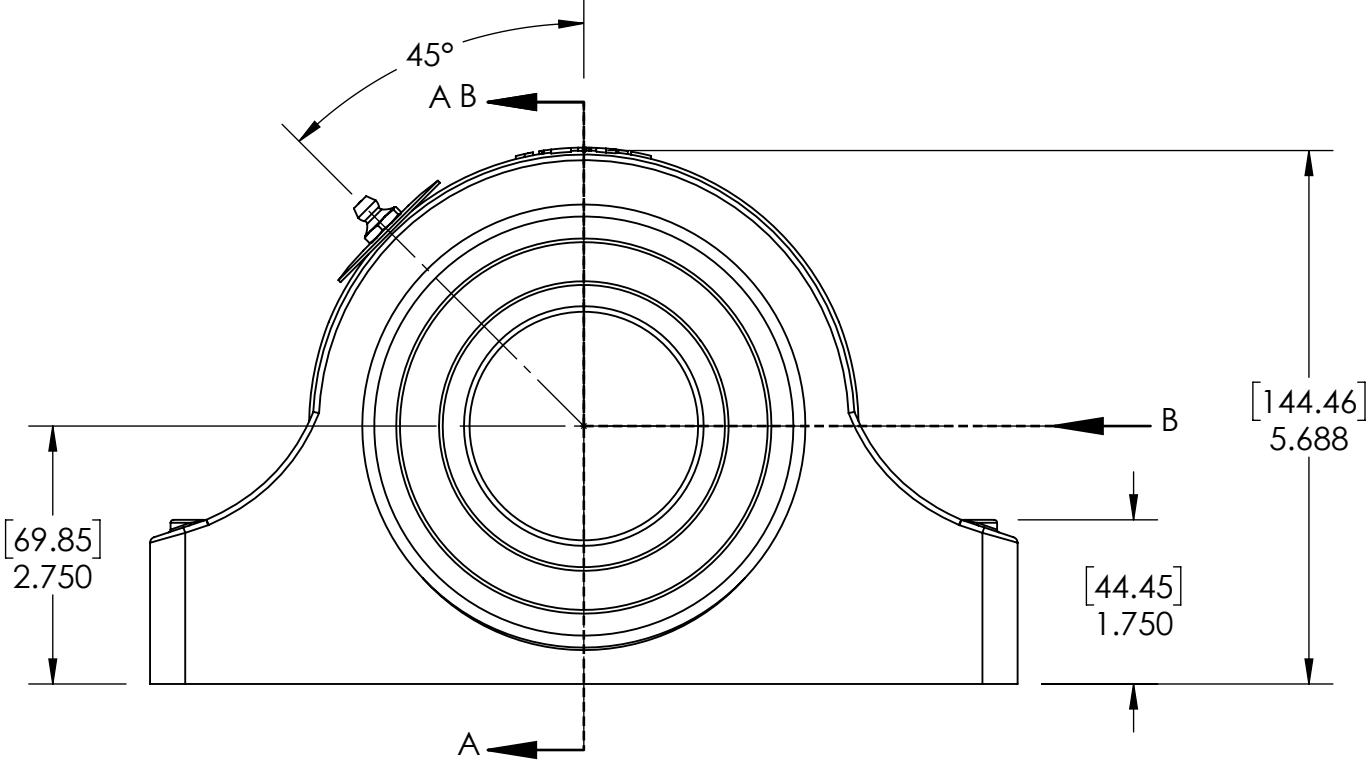
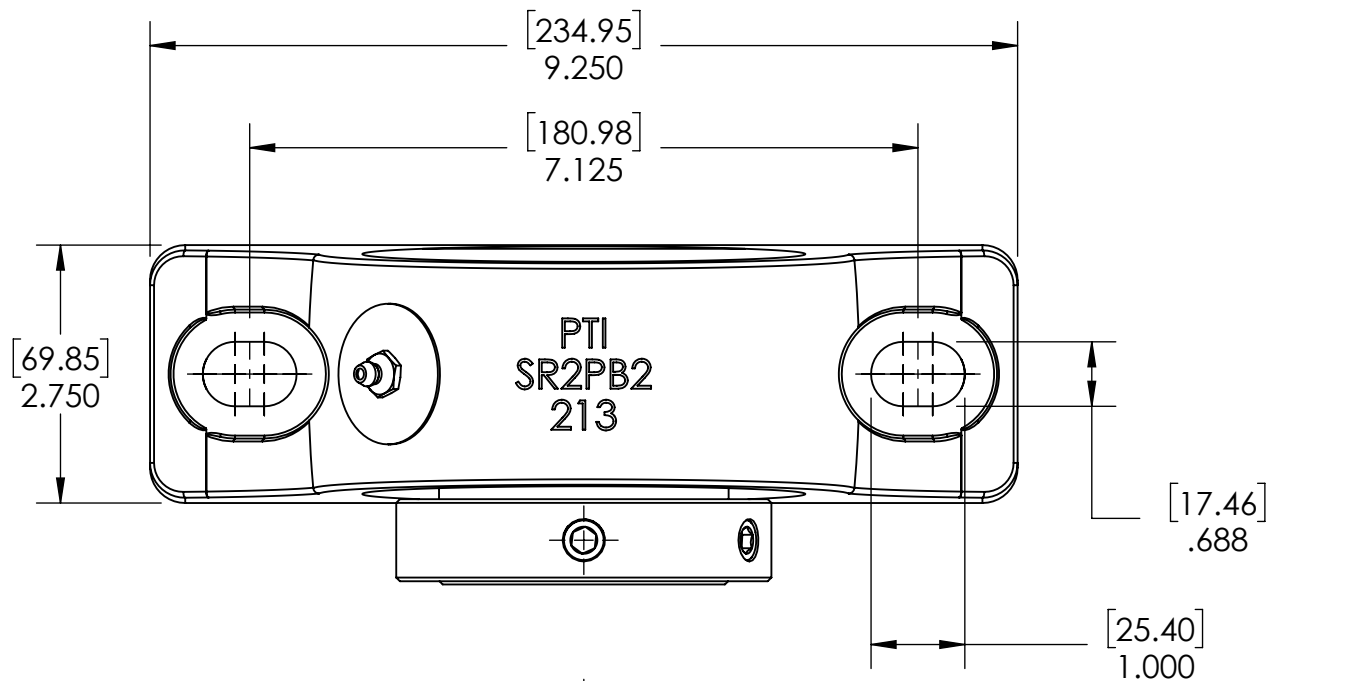

SECTION VIEW A-A

ITEM NO.	PART NUMBER	MATERIAL	COATING	QTY.
6	NP-SR2-EX	STEEL	N/A	1
5	1_8-27 ZERK	STEEL	ZINC PLATED	1
4	R3-476213	HNBR	N/A	2
3	OH120	STEEL	N/A	2
2	476213-207	BEARING STEEL	N/A	1
1	SR2PB2-213	DUCTILE IRON	POWDER COAT	1

SPECIFICATIONS		SOLVE		WEIGHT	
UNITS	IN [mm]	INDUSTRIAL MOTION GROUP		18.35 LBS	
LOAD RATINGS	C 37090 LBS Co 46090 LBS	PTI		MATERIAL SEE BOM	
SPEED RATING	1700 RPM	DWG. NO.		COATING SEE BOM	
GREASE TYPE	NLGI #2	PROPRIETARY AND CONFIDENTIAL		DRAWN SEC 04/15/2025	
GREASE FILL	40-60%	THE INFORMATION CONTAINED IN THIS DRAWING IS THE SOLE PROPERTY OF SOLVE IMAGING. ANY REPRODUCTION IN PART OR AS A WHOLE WITHOUT THE WRITTEN PERMISSION OF SOLVE IMAGING IS PROHIBITED.		CHECKED FP 04/15/2025	
OPERATING TEMP	-22°F - 290°F	DATE		BY	
SET SCREW SIZE	1/2-20UNF-3/4	REVISION DESCRIPTION		REV	
SET SCREW TORQUE	620 IN-LBS	SR2-PB2-207R3XP		SCALE 1:11	
SET SCREW AXIAL RETENTION	900 LBS			REV -	

9 8 7 6 5 4 3 2 1