

9 8 7 6 5 4 3 2 1

G F E D C B A

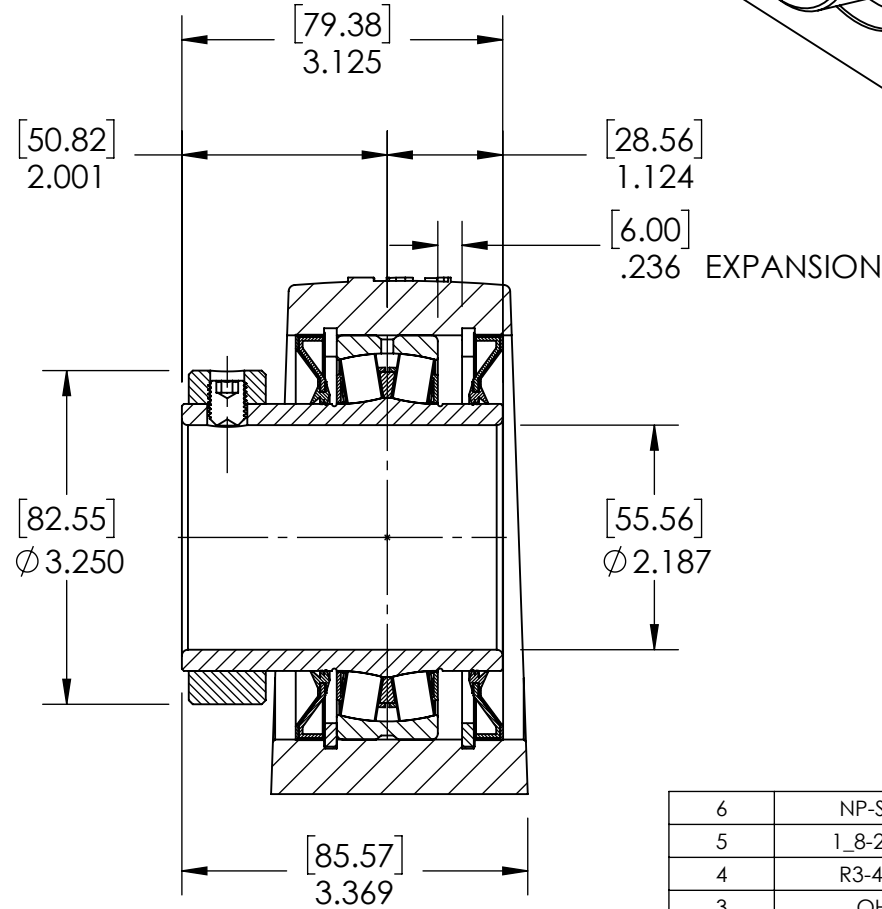
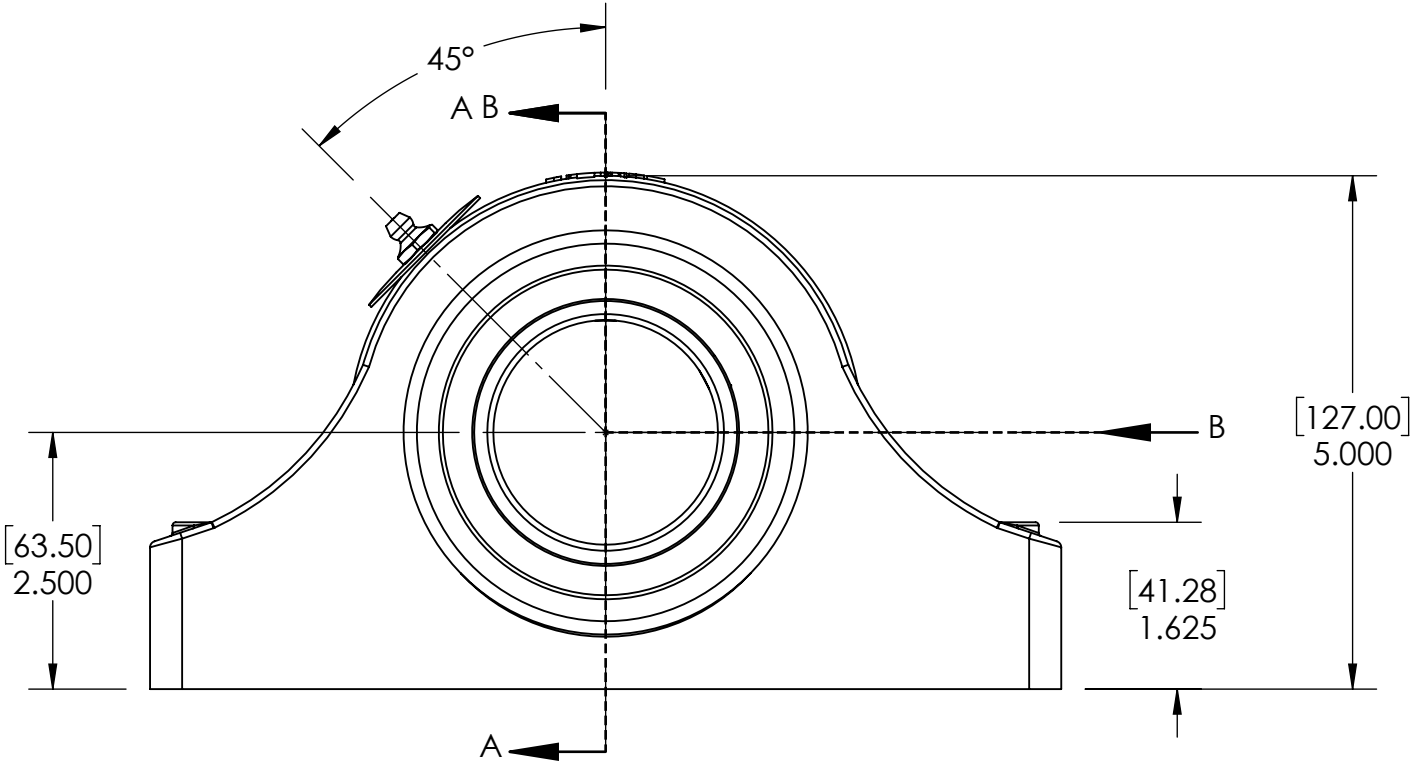
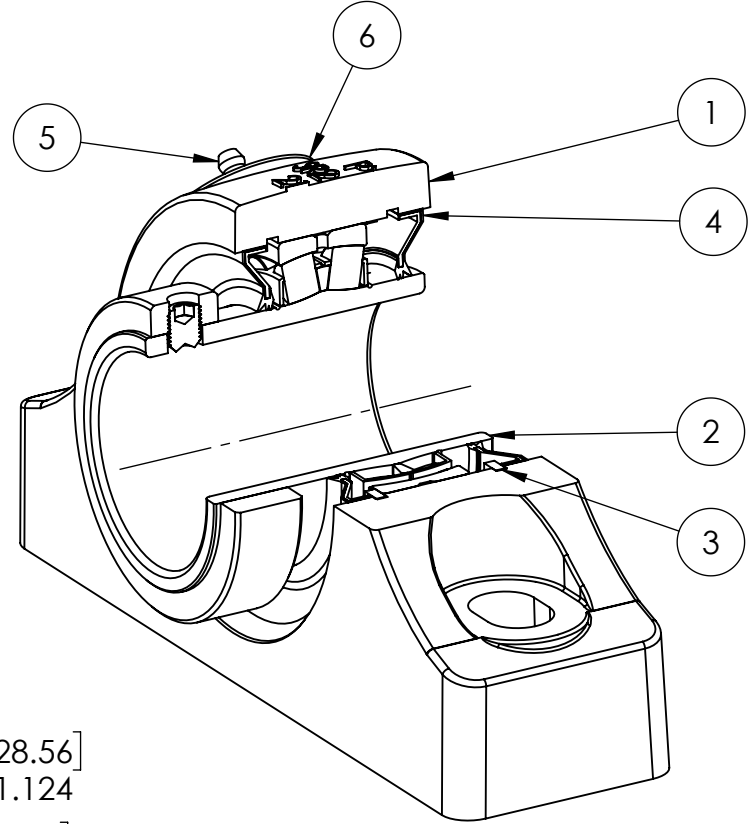
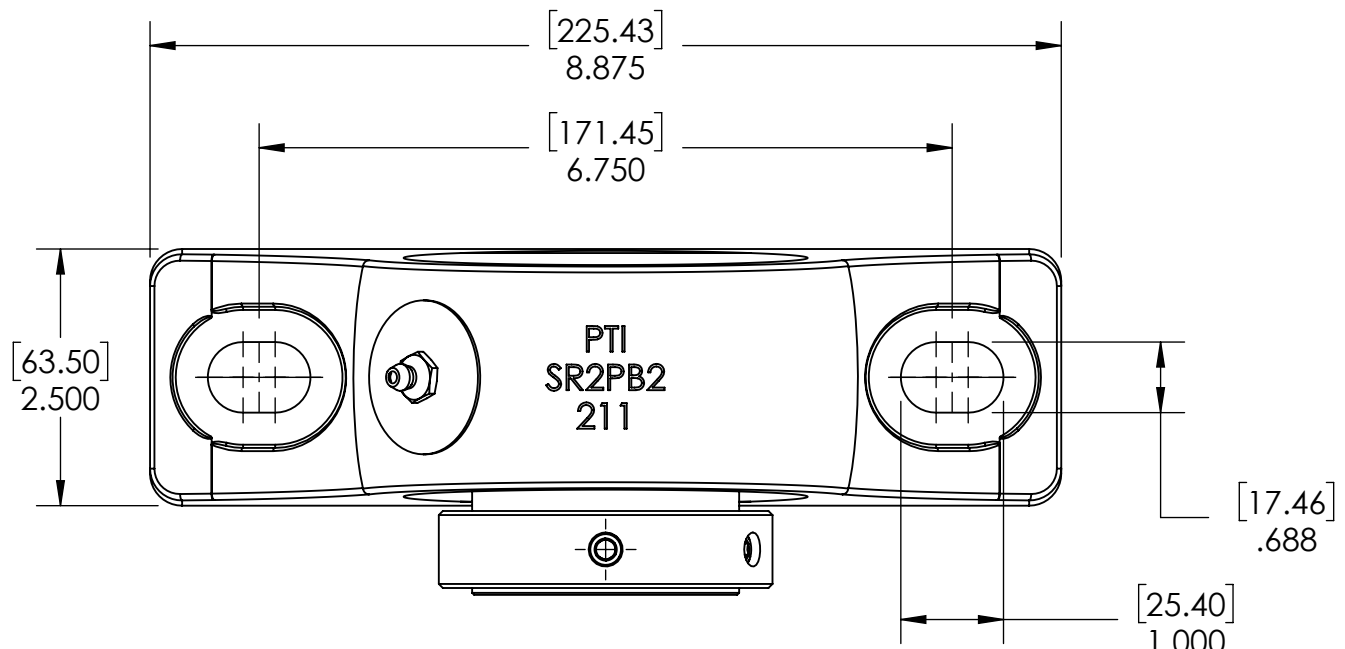

SECTION VIEW A-A

ITEM NO.	PART NUMBER	MATERIAL	COATING	QTY.
6	NP-SR2-EX	STEEL	N/A	1
5	1_8-27 ZERK	STEEL	ZINC PLATED	1
4	R3-476211	HNBR	N/A	2
3	OH100	STEEL	N/A	2
2	476211-203	BEARING STEEL	N/A	1
1	SR2PB2-211	DUCTILE IRON	POWDER COAT	1

SPECIFICATIONS	
UNITS	IN [mm]
LOAD RATINGS	C 23600 LBS Co 28100 LBS
SPEED RATING	2000 RPM
GREASE TYPE	NLGI #2
GREASE FILL	40-60%
OPERATING TEMP	-22°F - 290°F
SET SCREW SIZE	3/8-24UNF-1/2
SET SCREW TORQUE	250 IN-LBS
SET SCREW AXIAL RETENTION	515 LBS



WEIGHT	13.40 LBS
MATERIAL	SEE BOM
COATING	SEE BOM
DRAWN	SEC 03/18/2025
CHECKED	FP 04/15/2025
APPROVED	
THIRD ANGLE PROJECTION	

DATE	BY	REVISION DESCRIPTION	REV
ITEM DESCRIPTION: SR2-PB2-203R3XP			SCALE 1:12
			REV -

9 8 7 6 5 4 3 2 1

A B C D E F G