

9 8 7 6 5 4 3 2 1

G
F
E
D
C
B
A

G
F
E
D
C
B
A

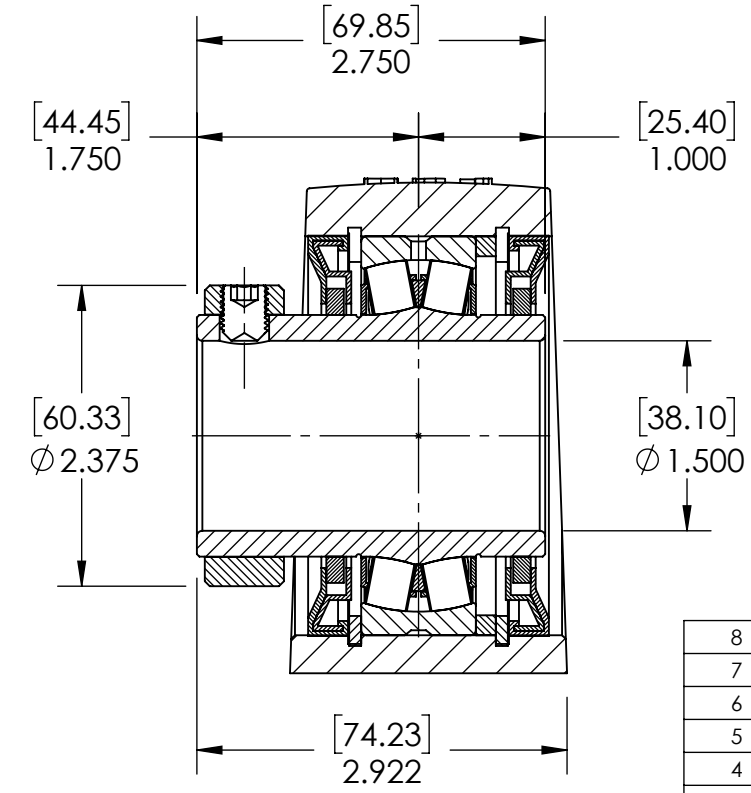
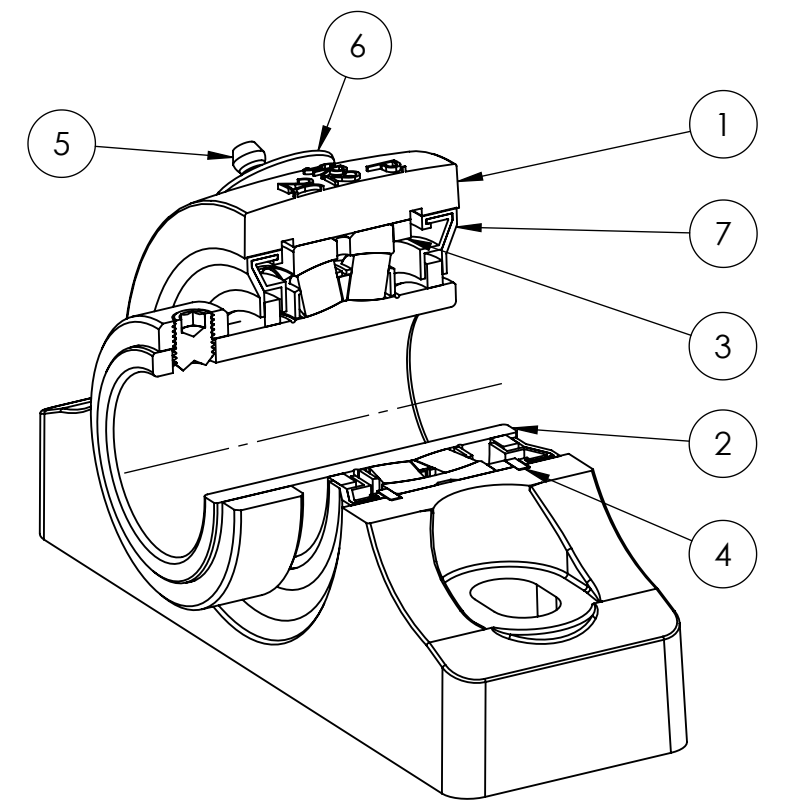
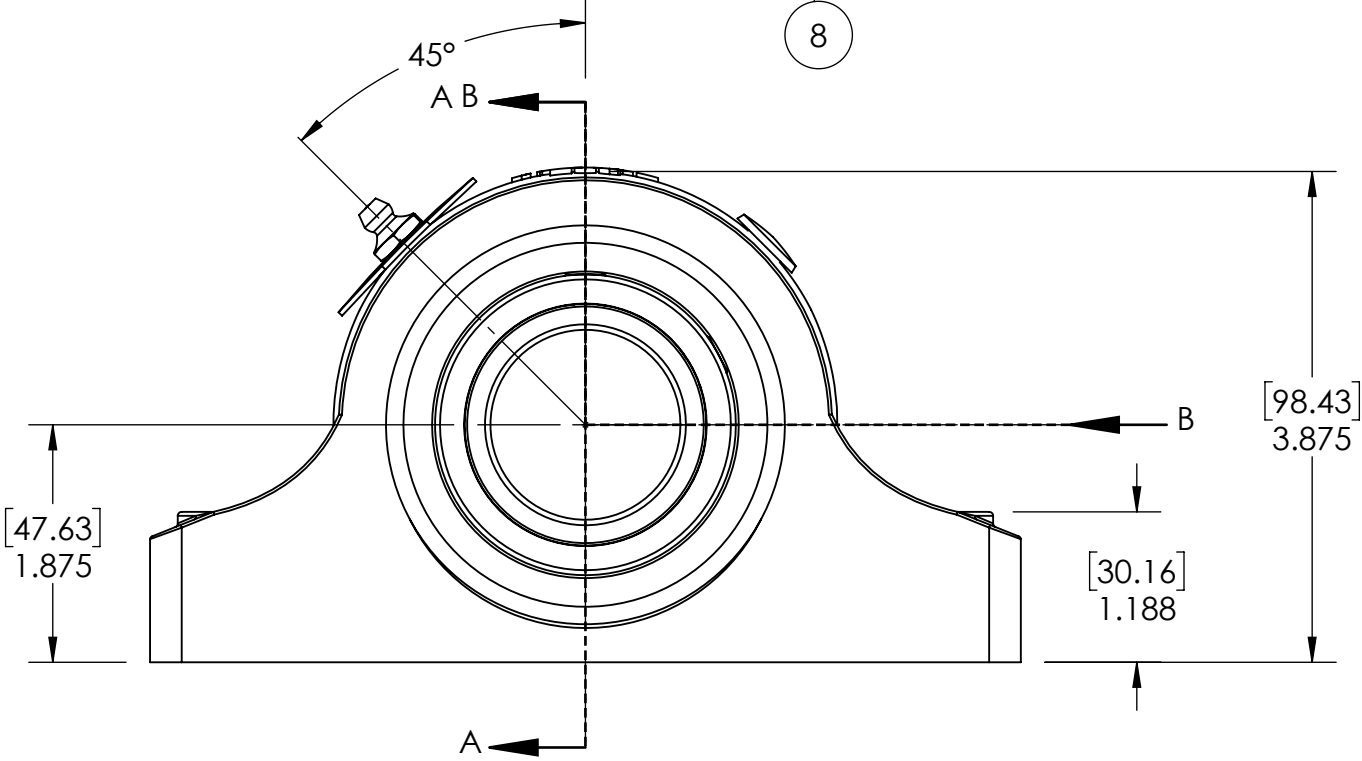
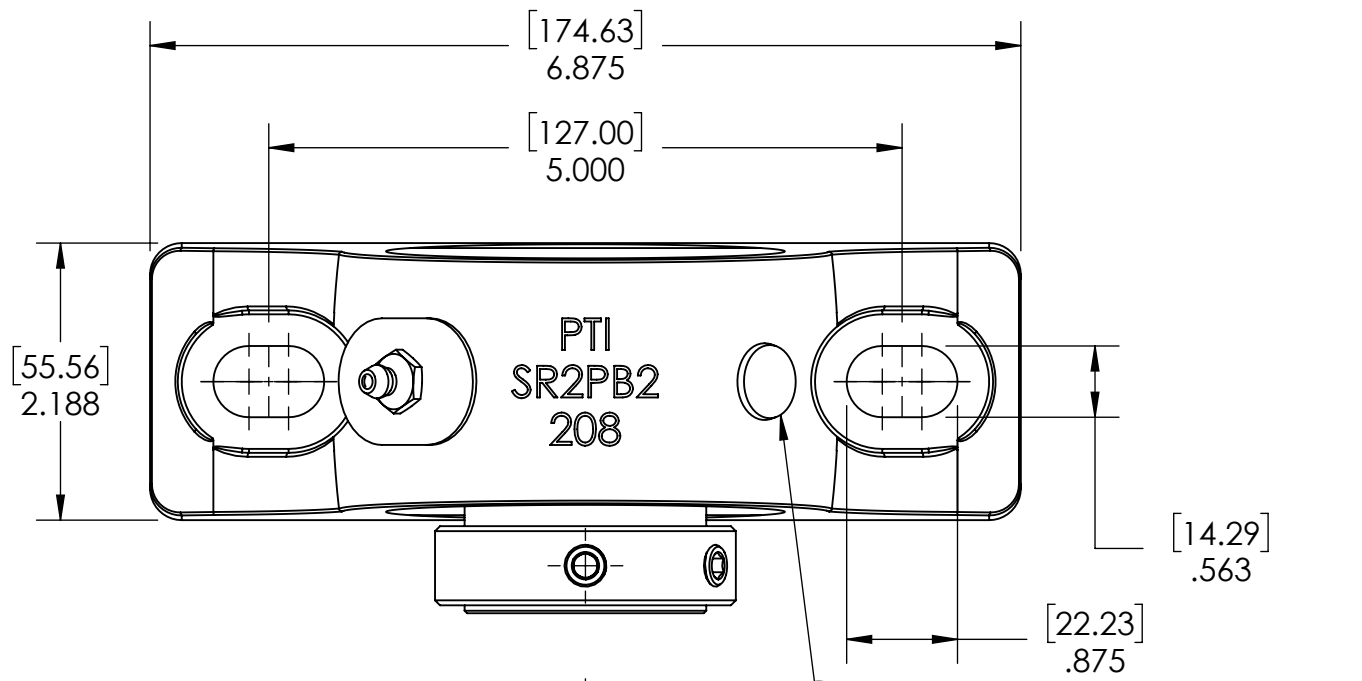

SECTION VIEW A-A

ITEM NO.	PART NUMBER	MATERIAL	COATING	QTY.
8	9mm SCREW CAP	PLASTIC	N/A	1
7	TL-476208	TEFLON	N/A	2
6	NPS-SR2-NE	STEEL	N/A	1
5	1_8-27 ZERK	STEEL	ZINC PLATED	1
4	OH80	STEEL	N/A	2
3	SR-FR80X4	STEEL	N/A	1
2	476208-108	BEARING STEEL	N/A	1
1	SR2PB2-208	DUCTILE IRON	POWDER COAT	1

SPECIFICATIONS	
UNITS	IN [mm]
LOAD RATINGS	C 17540 LBS Co 20230 LBS
SPEED RATING	3600 RPM
GREASE TYPE	NLGI #2
GREASE FILL	40-60%
OPERATING TEMP	-100°F - 400°F
SET SCREW SIZE	3/8-24UNF-1/2
SET SCREW TORQUE	250 IN-LBS
SET SCREW AXIAL RETENTION	515 LBS

SOLVE INDUSTRIAL MOTION GROUP
PTI
 DWG. NO.

WEIGHT	7.19 LBS
MATERIAL	SEE BOM
COATING	SEE BOM
DRAWN	SEC 03/12/2025
CHECKED	FP 04/15/2025
APPROVED	

DATE	BY	REVISION DESCRIPTION	REV
ITEM DESCRIPTION: SR2-PB2-108TLNE			SCALE 1:15
			REV -

9 8 7 6 5 4 3 2 1