

9 8 7 6 5 4 3 2 1

G F E D C B A

A B C D E F G

9 8 7 6 5 4 3 2 1

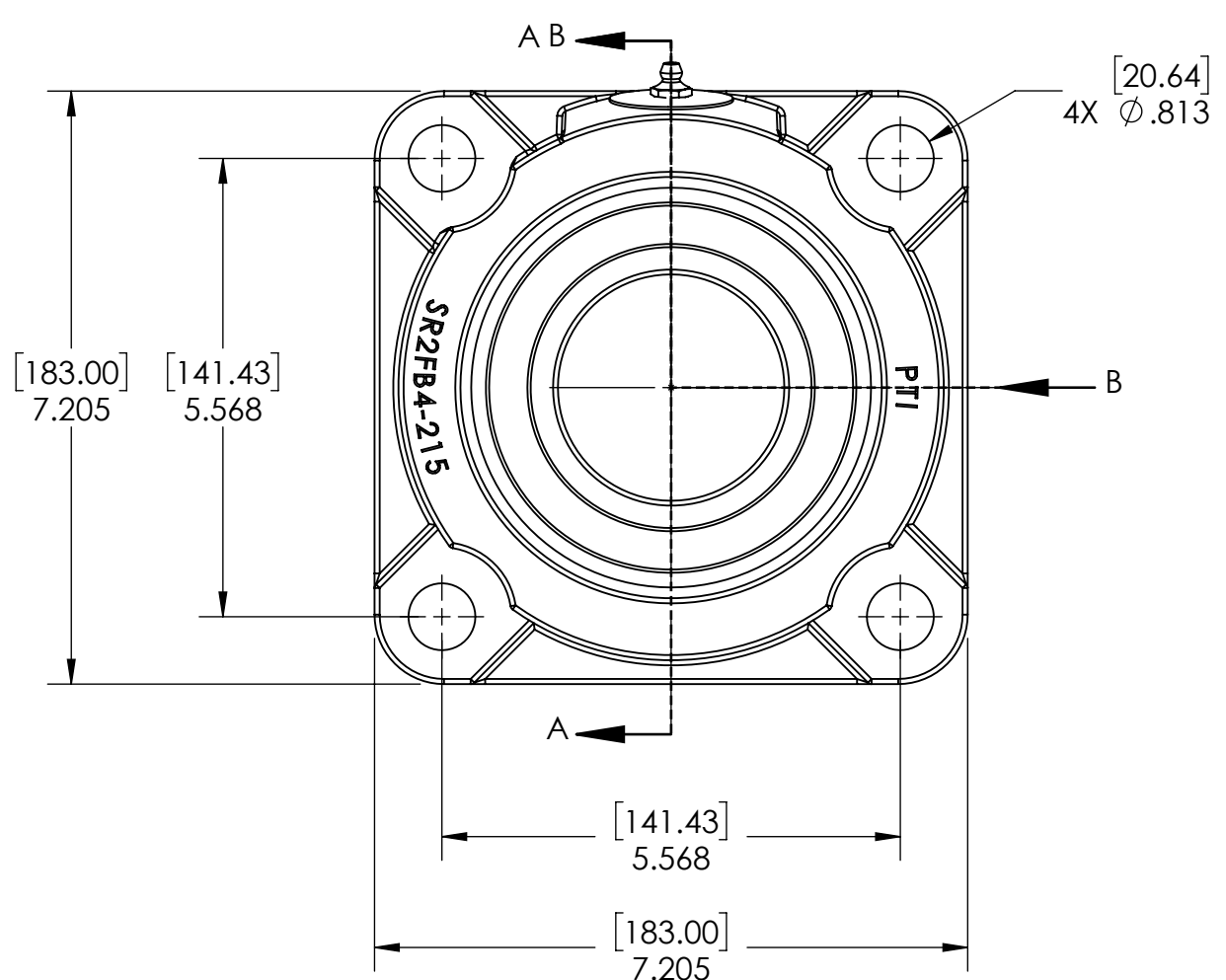
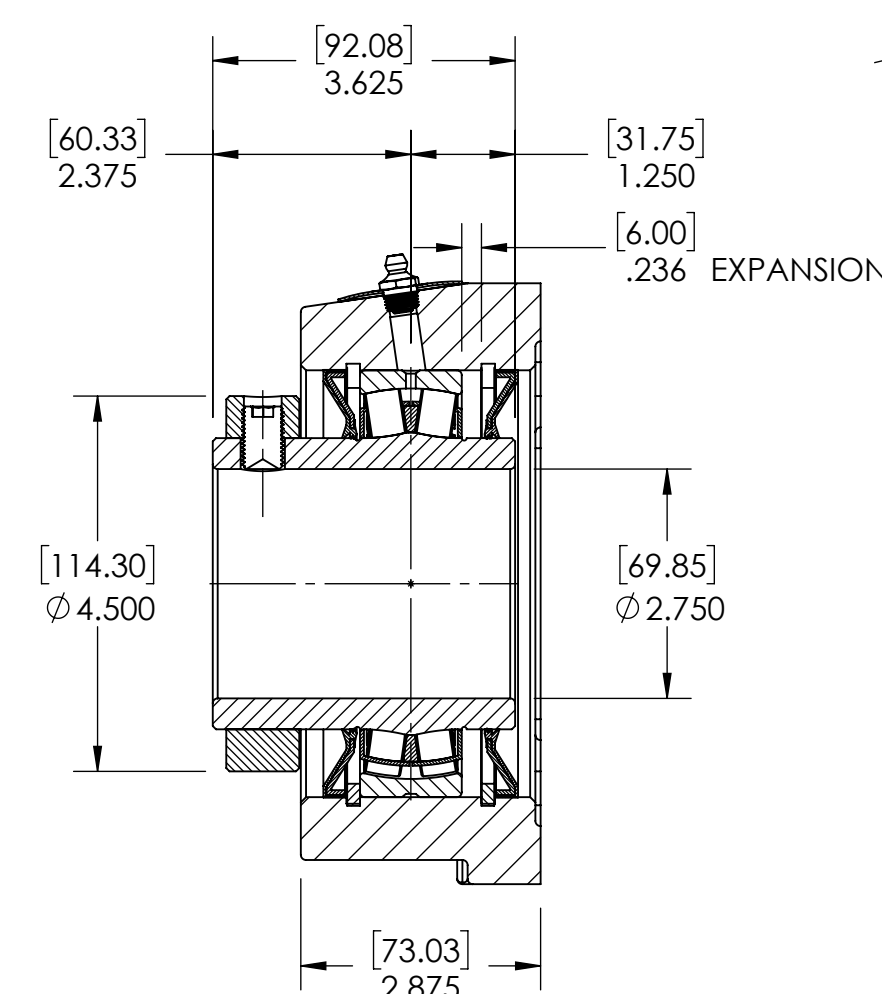
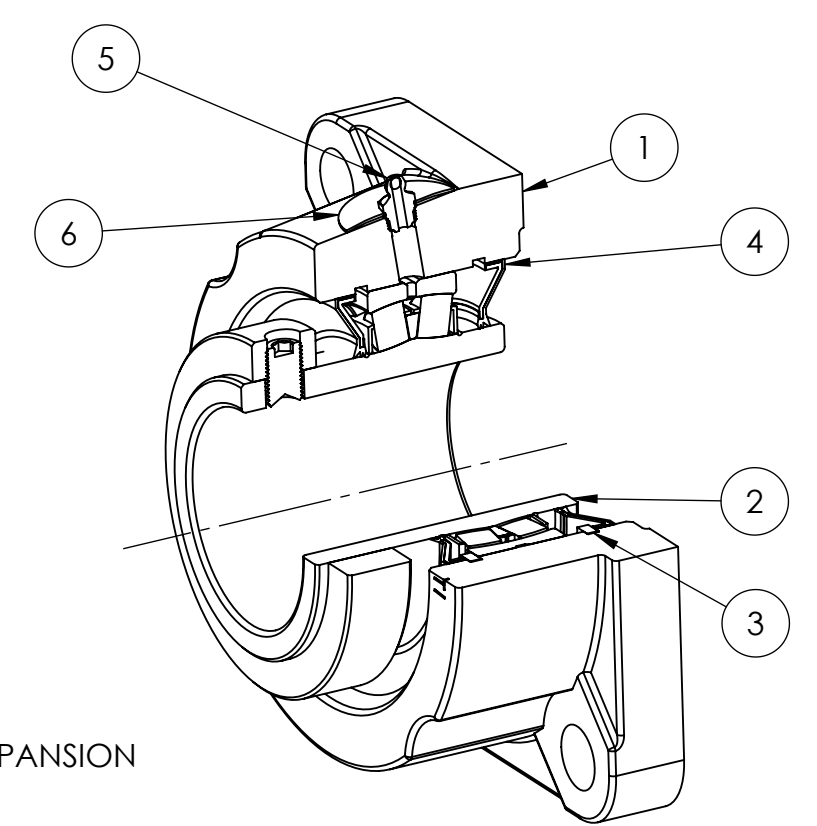
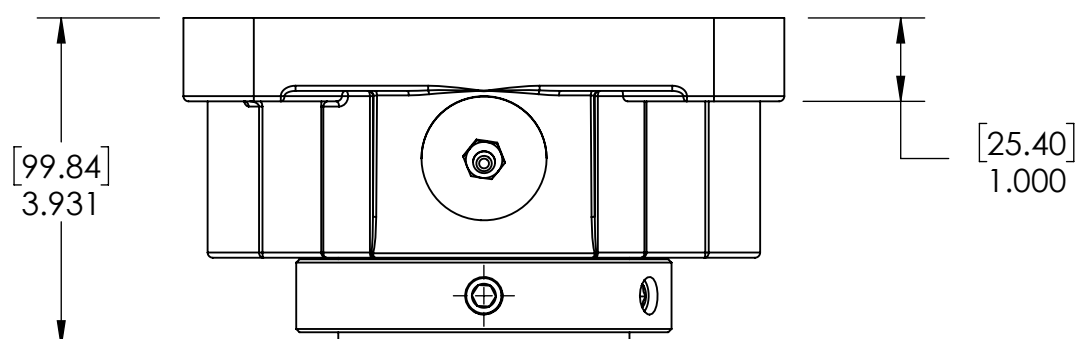

SECTION VIEW A-A

ITEM NO.	PART NUMBER	MATERIAL	COATING	QTY.
6	NP-SR2-EX	STEEL	N/A	1
5	1_8-27 ZERK	STEEL	ZINC PLATED	1
4	R3-476215	HNBR	N/A	2
3	OH130	STEEL	N/A	2
2	476215-212	BEARING STEEL	N/A	1
1	SR2FB4-215	DUCTILE IRON	POWDER COAT	1

SPECIFICATIONS		WEIGHT	
UNITS	IN [mm]		22.22 LBS
LOAD RATINGS	C 41590 LBS Co 52830 LBS	MATERIAL	SEE BOM
SPEED RATING	1500 RPM	COATING	SEE BOM
GREASE TYPE	NLGI #2	DRAWN	SEC 04/15/2025
GREASE FILL	40-60%	CHECKED	FP 04/15/2025
OPERATING TEMP	-22°F - 290°F	APPROVED	
SET SCREW SIZE	1/2-20UNF-3/4	THIRD ANGLE PROJECTION	
SET SCREW TORQUE	620 IN-LBS		
SET SCREW AXIAL RETENTION	900 LBS		



PROPRIETARY AND CONFIDENTIAL
THE INFORMATION CONTAINED IN THIS DRAWING IS THE SOLE PROPERTY OF SOLVE IMG. ANY REPRODUCTION IN PART OR AS A WHOLE WITHOUT THE WRITTEN PERMISSION OF SOLVE IMG IS PROHIBITED.

DATE	BY	REVISION DESCRIPTION	REV
		ITEM DESCRIPTION: SR2-FB4-212R3XP	SCALE 1:11
			REV -