

9 8 7 6 5 4 3 2 1

G F E D C B A

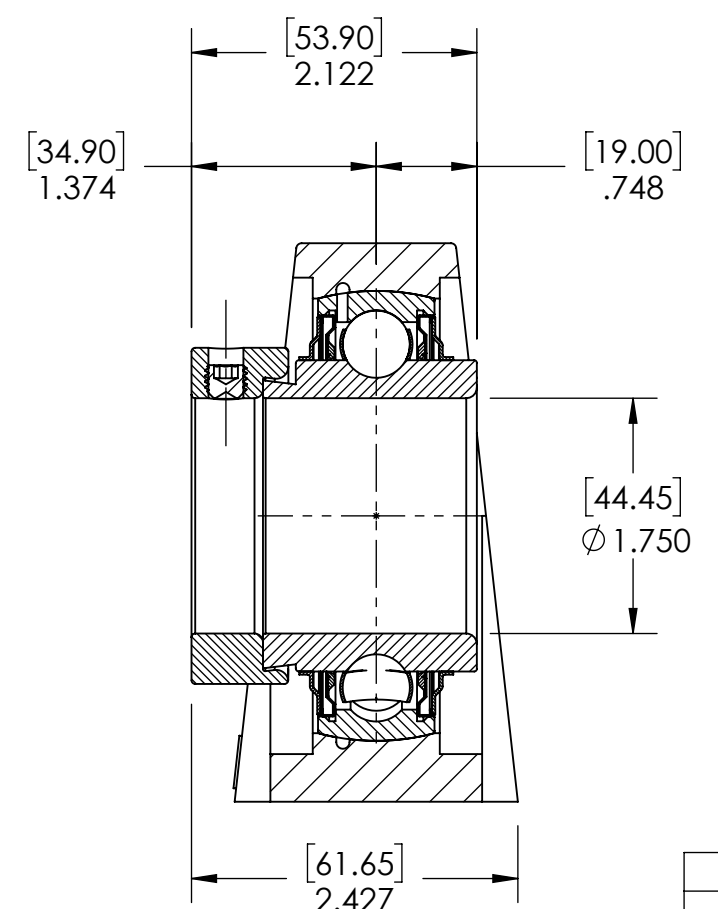
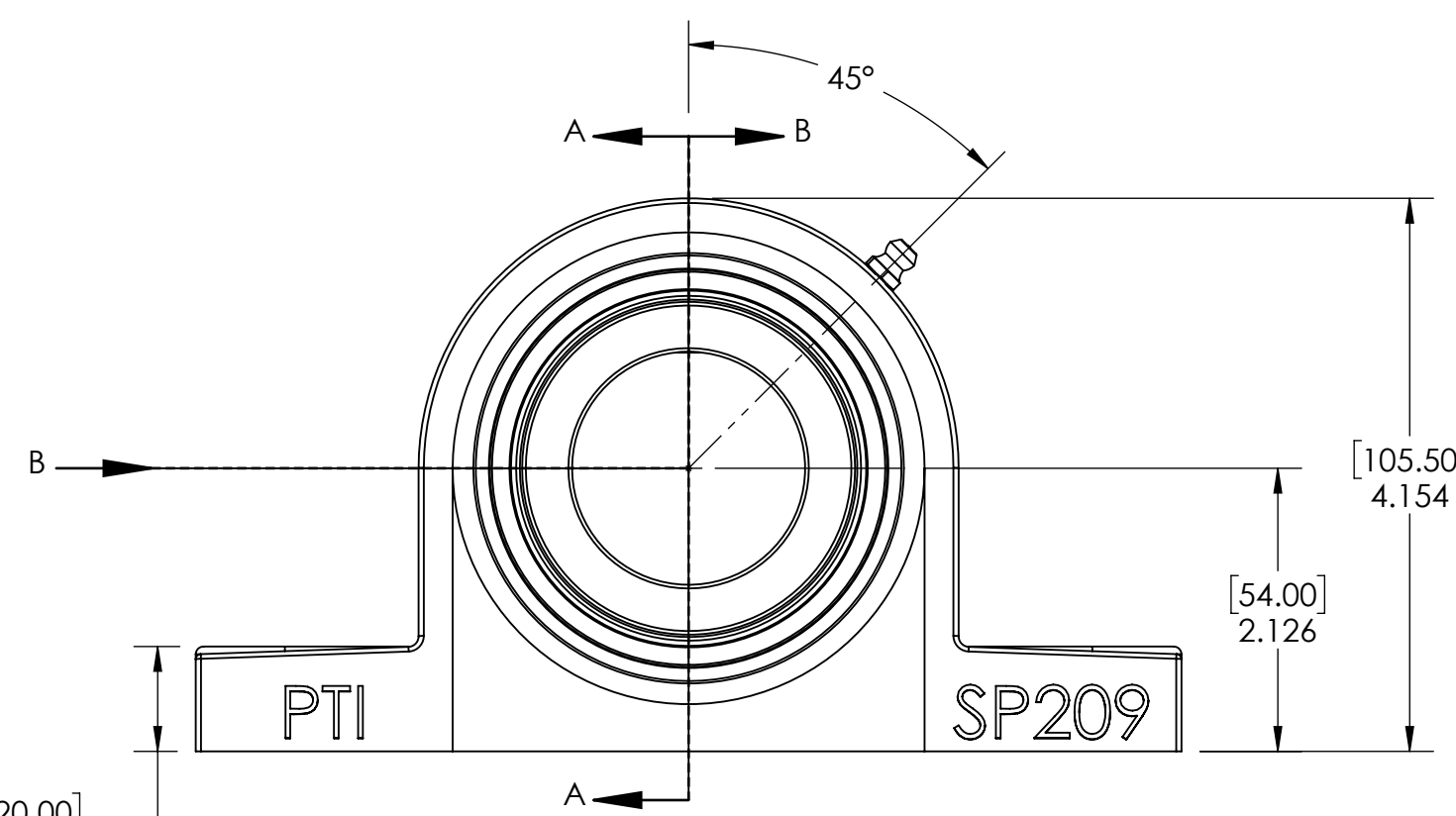
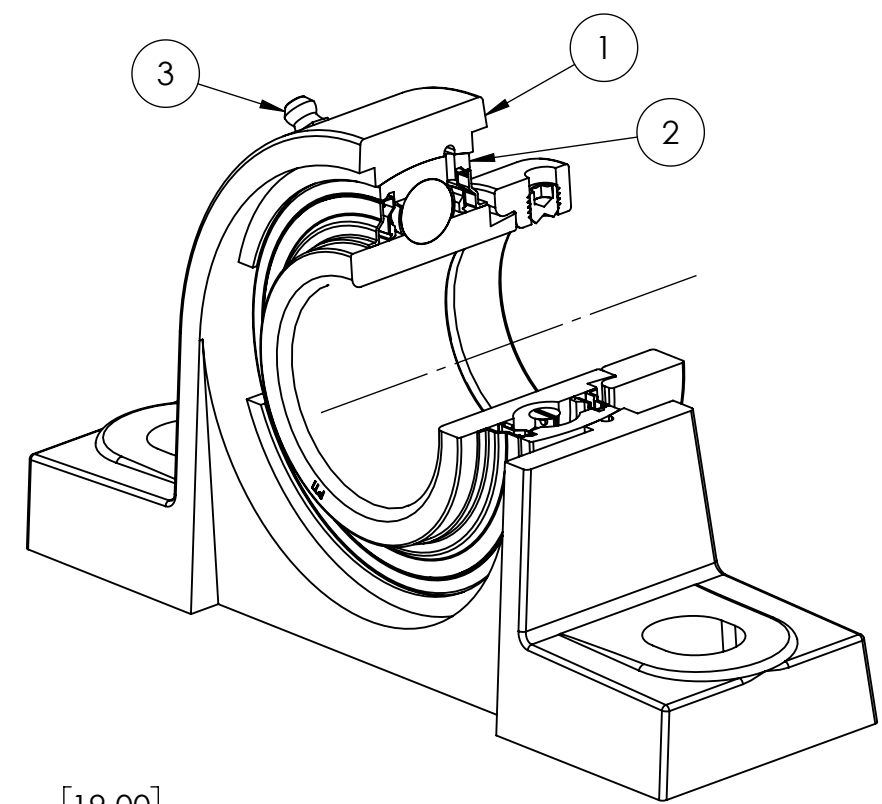
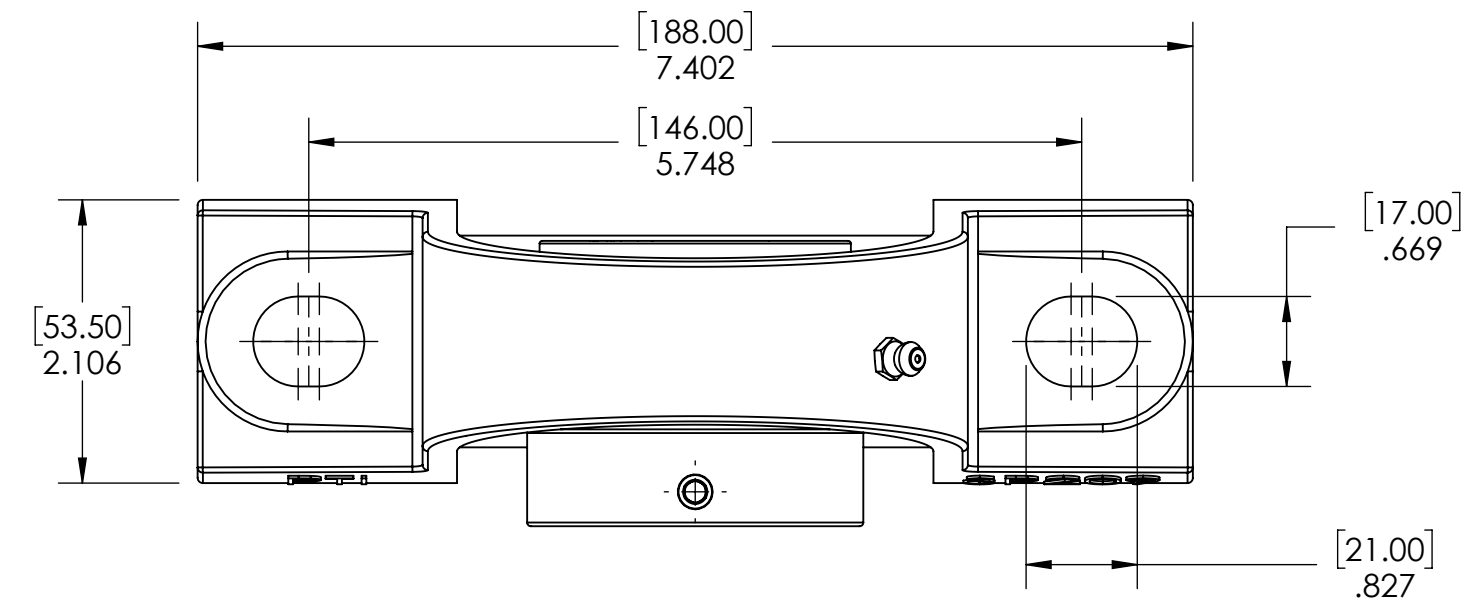

SECTION VIEW A-A

ITEM NO.	PART NUMBER	MATERIAL	COATING	QTY.
3	M6 ZERK	STAINLESS STEEL	N/A	1
2	SHC209-28	STAINLESS STEEL	N/A	1
1	SP209	STAINLESS STEEL	N/A	1

SPECIFICATIONS		WEIGHT	
UNITS:	IN (mm)		5.61 LBS
LOAD RATINGS	C: 6,200 LBS Co: 3,600 LBS	MATERIAL	SEE BOM
SPEED RATING	3700 RPM	COATING	SEE BOM
GREASE TYPE	FM222	DRAWN	SEC 12/26/2024
GREASE FILL	40%	CHECKED	AK 01/09/2025
OPERATING TEMP	-10°F - 250°F	APPROVED	
SEAL TYPE	K-TYPE		
INTERNAL CLEARANCE	C3		
TORQUE SETTING ON SET SCREWS			



DATE BY REVISION DESCRIPTION
 ITEM DESCRIPTION: SHCSP209-28

DATE	BY	REVISION DESCRIPTION	REV
			SCALE 1:8
			REV -

9 8 7 6 5 4 3 2 1

A B C D E F G