

9 8 7 6 5 4 3 2 1

G
F
E
D
C
B
A

G
F
E
D
C
B
A

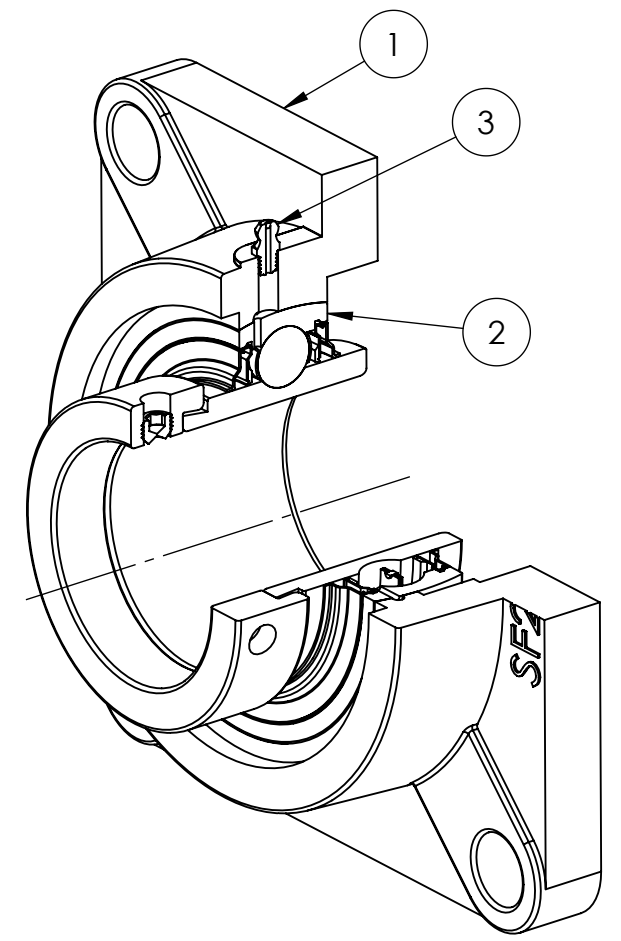
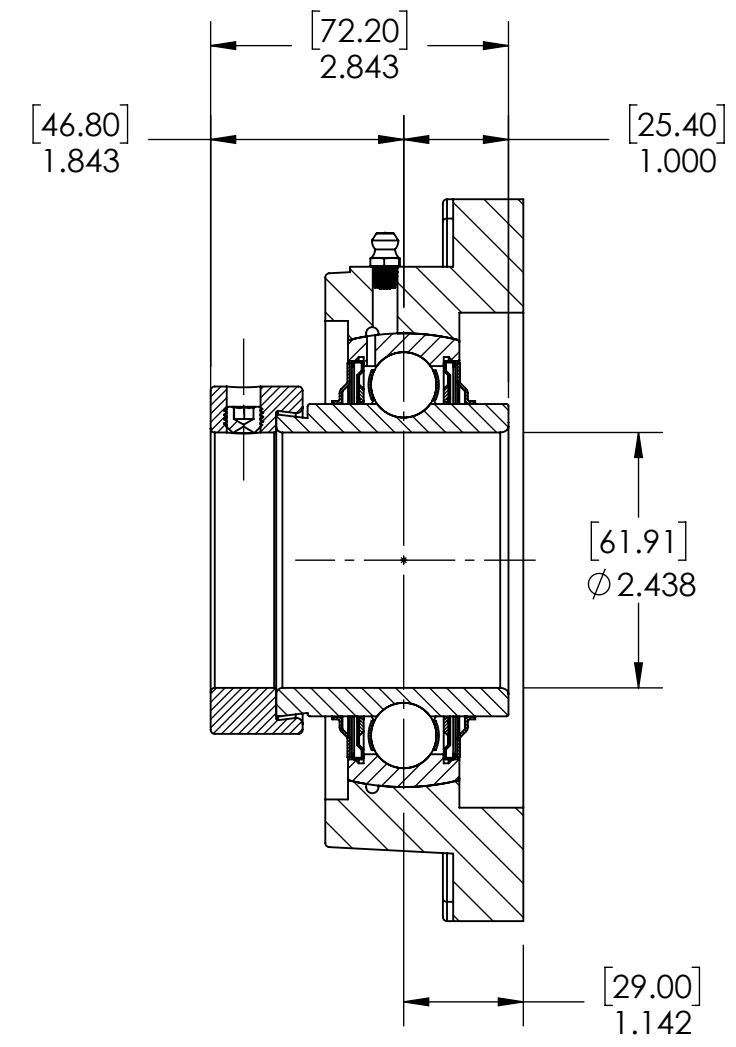
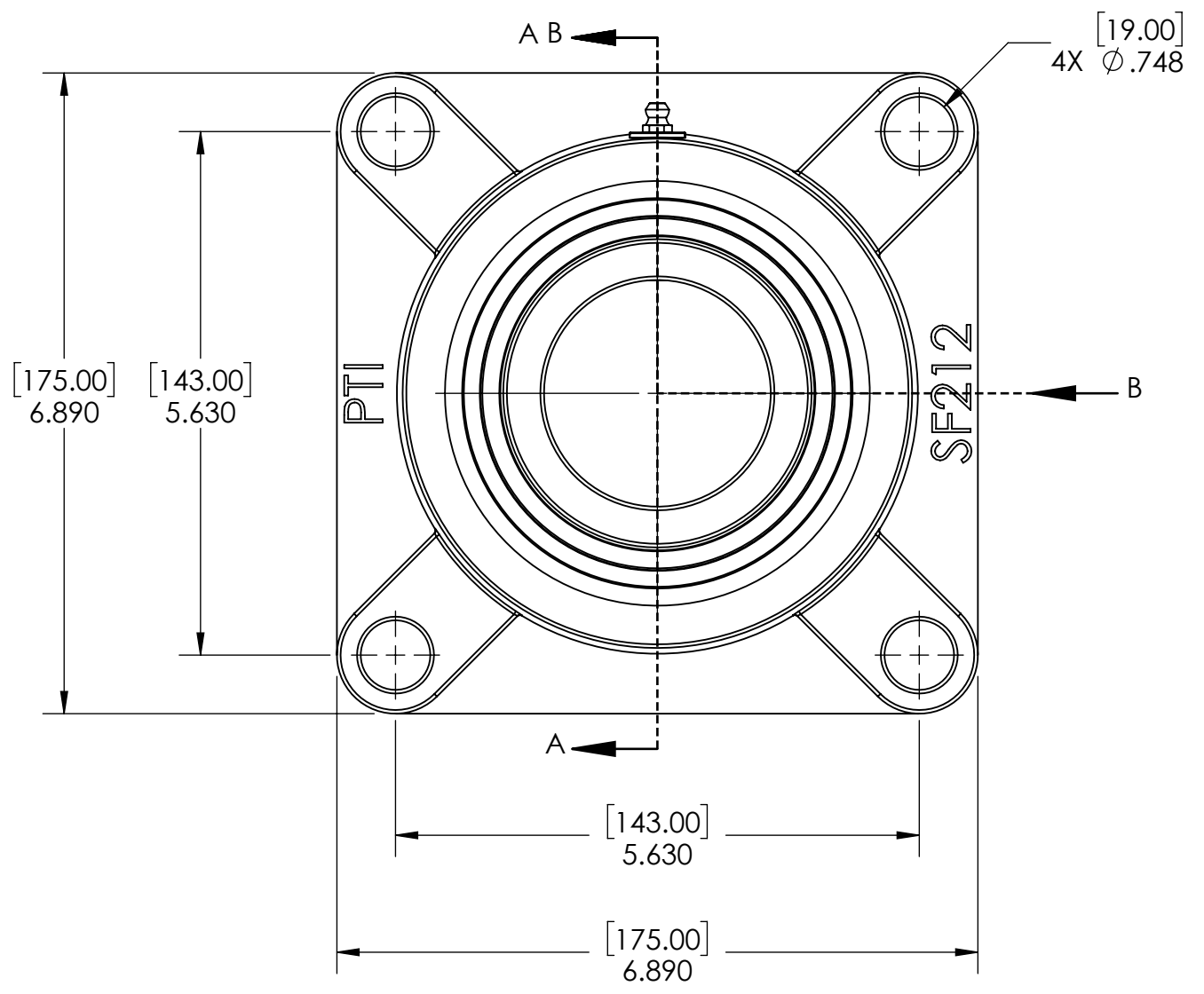
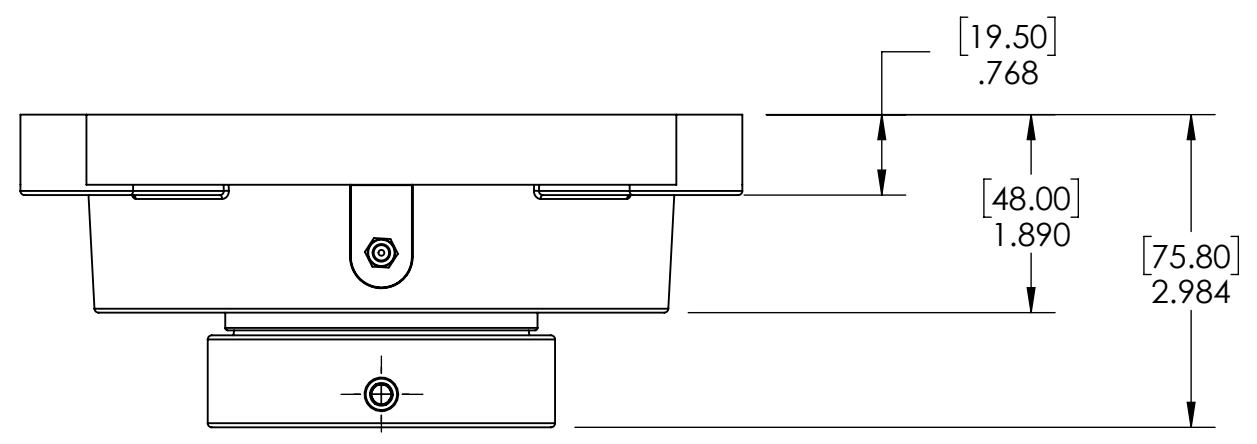

ITEM NO.	PART NUMBER	MATERIAL	COATING	QTY.
3	M6 ZERK	STAINLESS STEEL	N/A	1
2	SHC212-39	STAINLESS STEEL	N/A	1
1	SF212	STAINLESS STEEL	N/A	1

SPECIFICATIONS		WEIGHT	
UNITS:	IN (mm)		11.96 LBS
LOAD RATINGS	C: 9,000 LBS Co: 6,900 LBS	MATERIAL	SEE BOM
SPEED RATING	2800 RPM	COATING	SEE BOM
GREASE TYPE	FM222	DRAWN	SEC 01/09/2025
GREASE FILL	40%	CHECKED	SEC 01/09/2025
OPERATING TEMP	-10°F - 250°F	APPROVED	
SEAL TYPE	K-TYPE		
INTERNAL CLEARANCE	C3		
TORQUE SETTING ON SET SCREWS			



DATE BY REVISION DESCRIPTION
 ITEM DESCRIPTION: SHCSF212-39
 DWG. NO. PROPRIETARY AND CONFIDENTIAL
 THE INFORMATION CONTAINED IN THIS DRAWING IS THE SOLE PROPERTY OF SOLVE IMG. ANY REPRODUCTION IN PART OR AS A WHOLE WITHOUT THE WRITTEN PERMISSION OF SOLVE IMG IS PROHIBITED.

DATE	BY	REVISION DESCRIPTION	REV

9 8 7 6 5 4 3 2 1