

9 8 7 6 5 4 3 2 1

G F E D C B A

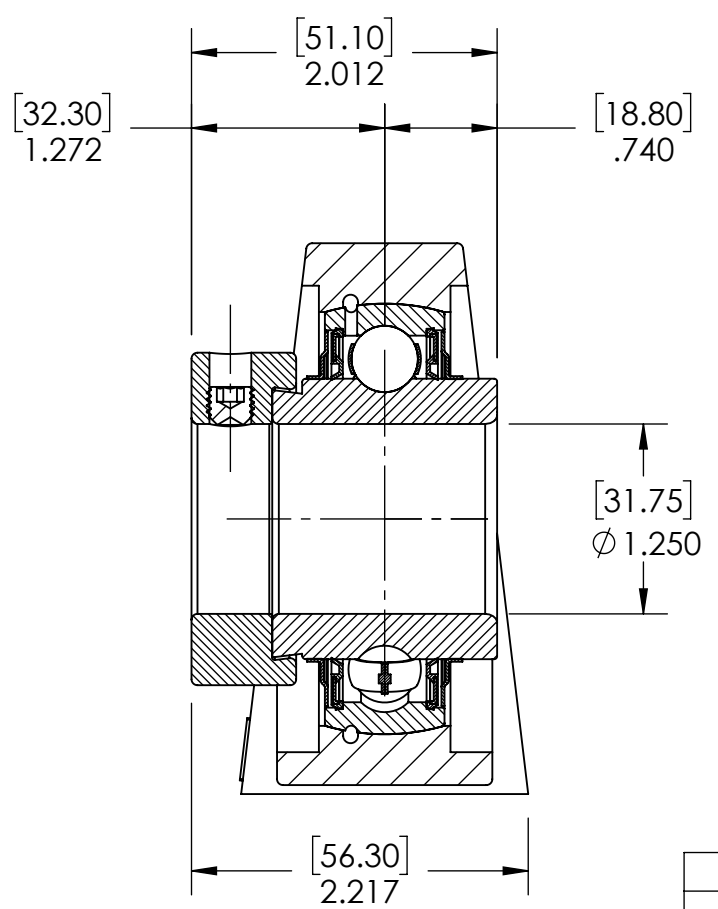
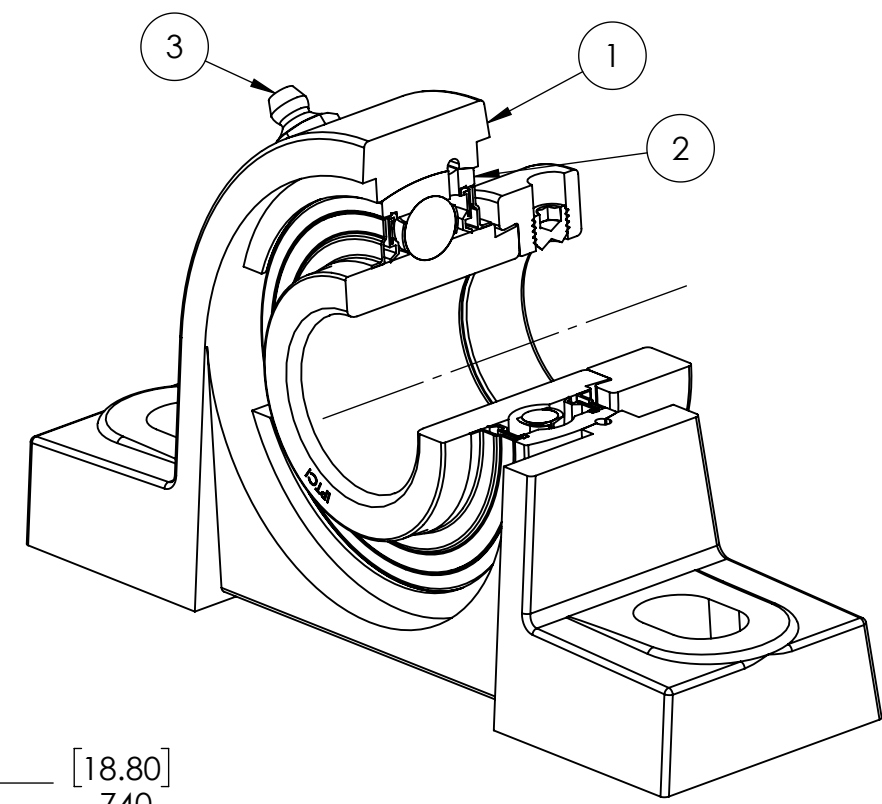
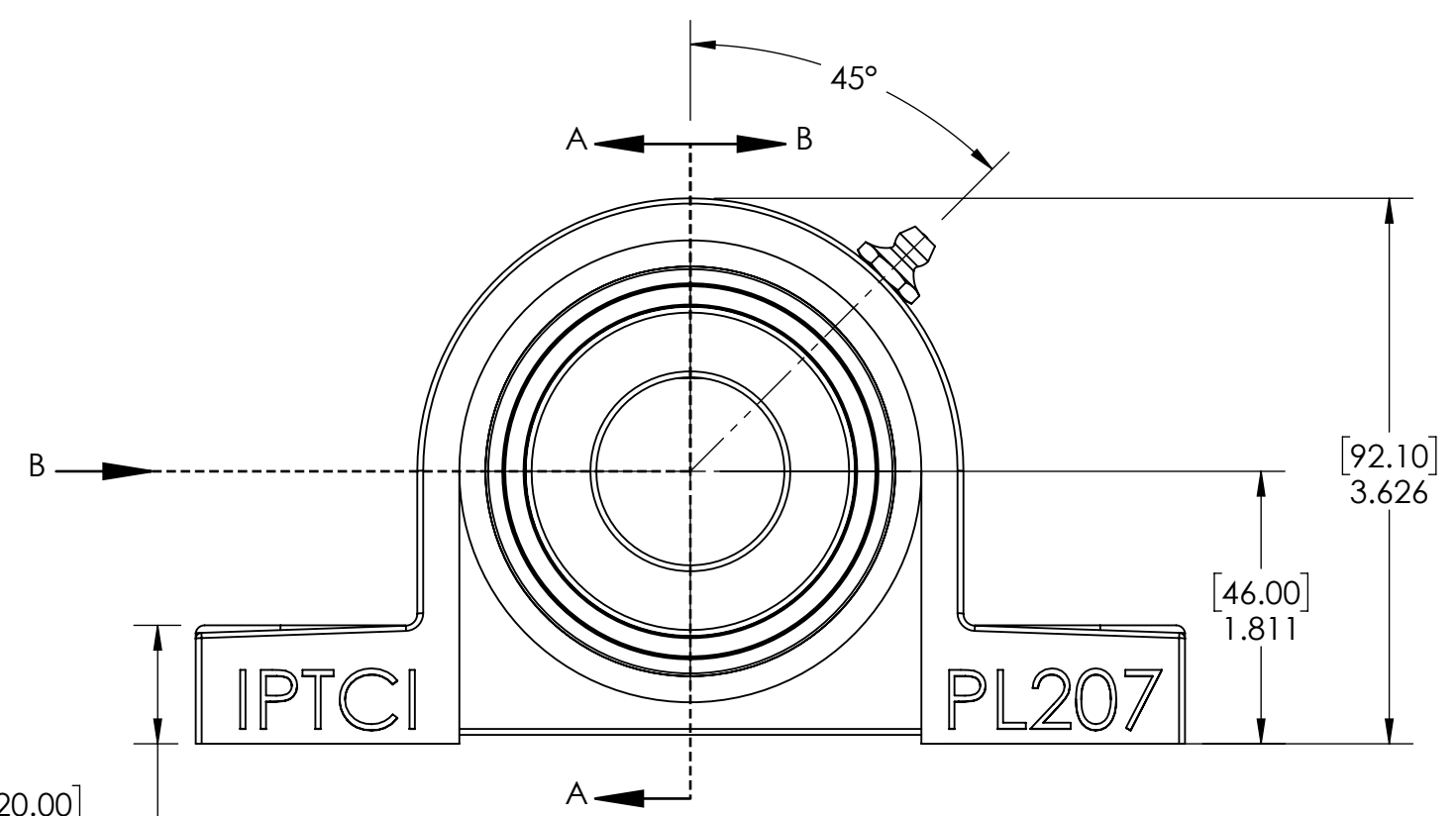
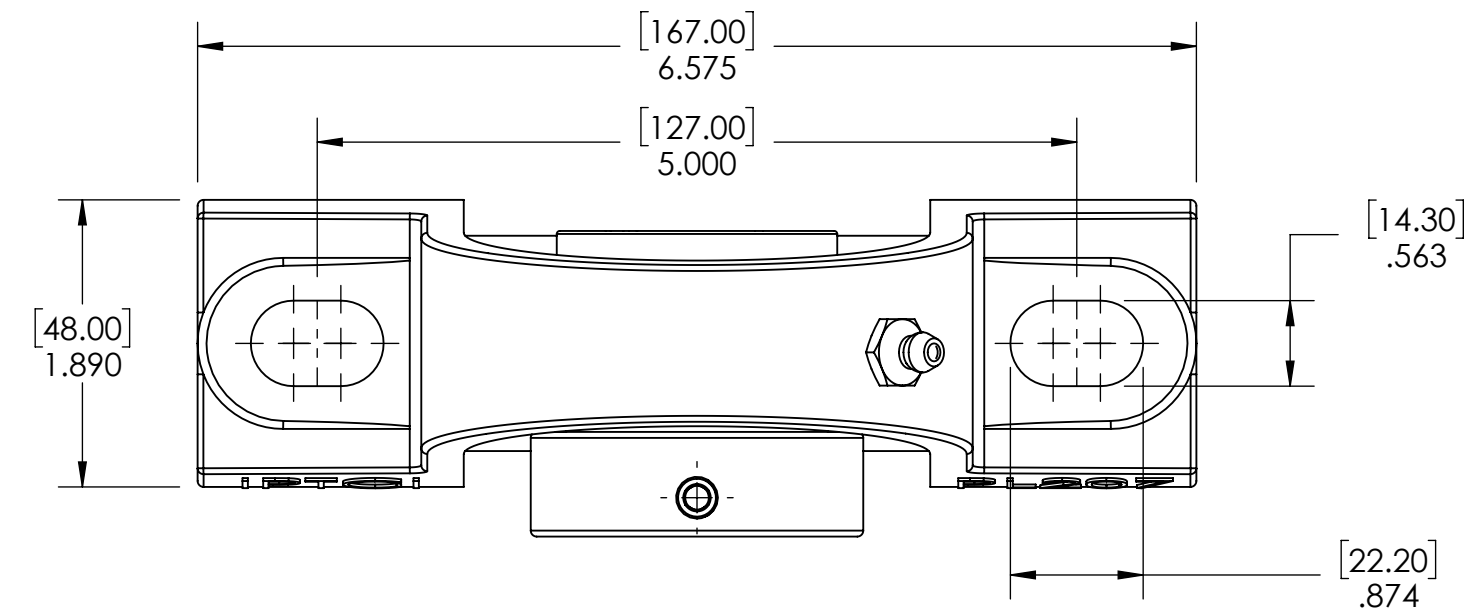

SECTION VIEW A-A

ITEM NO.	PART NUMBER	MATERIAL	COATING	QTY.
3	1/8-27	STEEL	ZINC PLATED	1
2	NA207-20	BEARING STEEL	N/A	1
1	PL207	CAST IRON	POWDER COAT	1

SPECIFICATIONS	
UNITS:	IN (mm)
LOAD RATINGS	C: 5.535 LBS Co: 3.340 LBS
SPEED RATING	4300 RPM
GREASE TYPE	NLGI #2
GREASE FILL	45%
OPERATING TEMP	32°F - 200°F
SEAL TYPE	B-TYPE
INTERNAL CLEARANCE	C3
TORQUE SETTING ON SET SCREWS	

**SOLVE**  
INDUSTRIAL MOTION GROUP

SIZE **B**  
**IPTCI**  
BEARINGS

DWG. NO.

WEIGHT	4.10
MATERIAL	SEE NOTES
COATING	SEE NOTES
DRAWN	SEC 12/16/2024
CHECKED	SEC 04/14/2025
APPROVED	
THIRD ANGLE PROJECTION	

DATE	BY	REVISION DESCRIPTION	REV
ITEM DESCRIPTION: NAPL207-20			SCALE 1:9
			REV -

9 8 7 6 5 4 3 2 1

A B C D E F G