

9 8 7 6 5 4 3 2 1

G
F
E
D
C
B
A

G
F
E
D
C
B
A

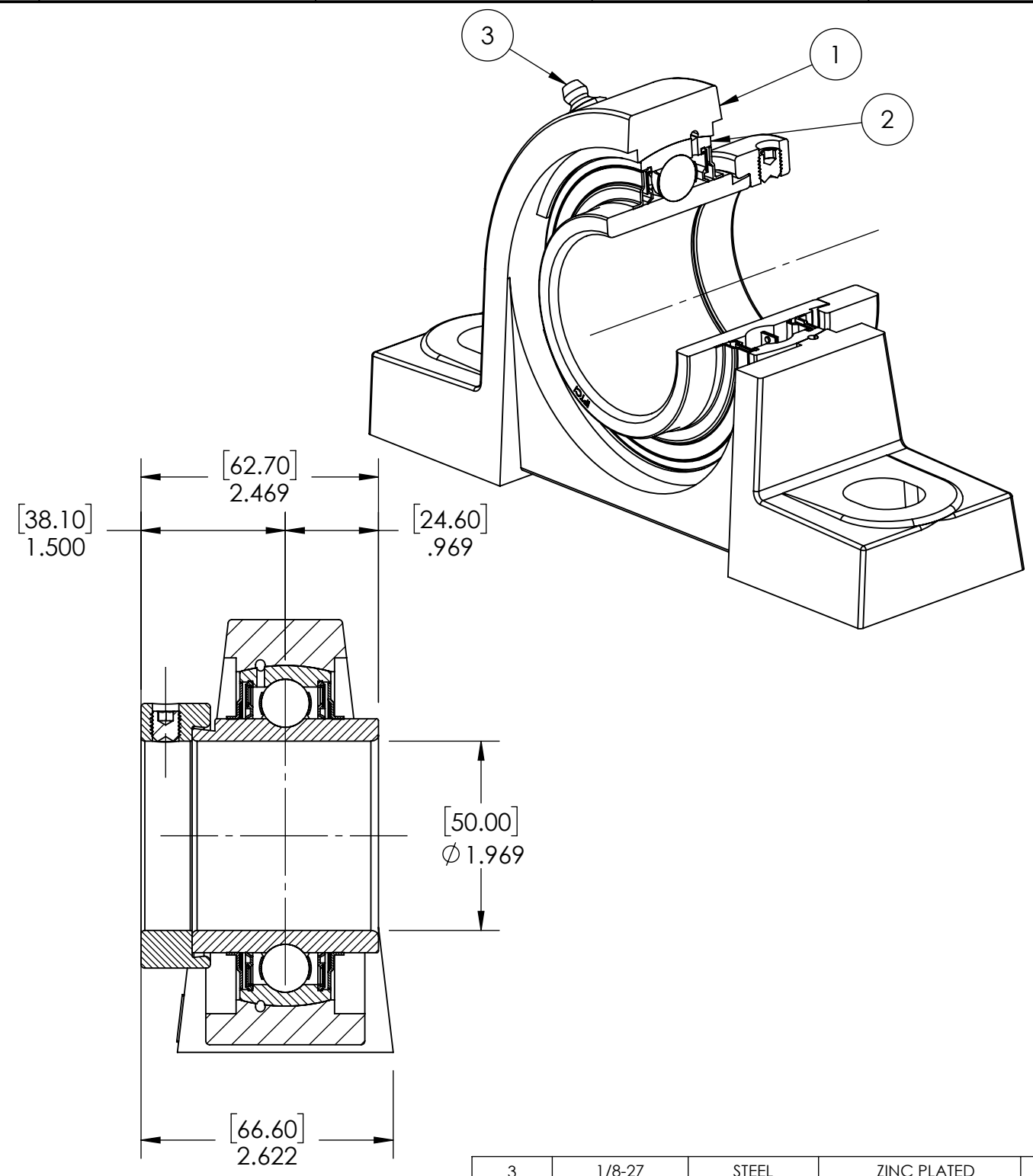
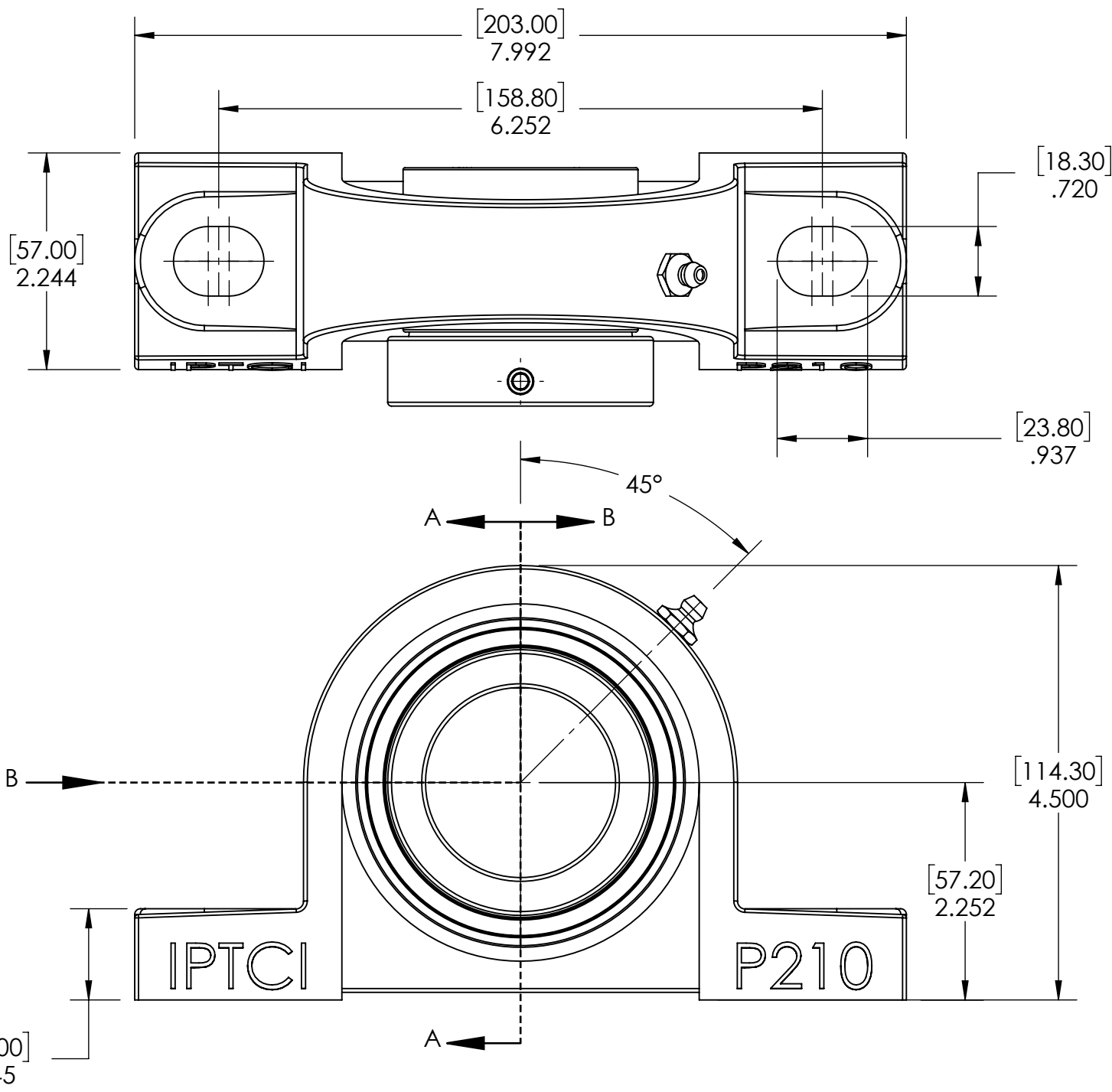

SECTION VIEW A-A

ITEM NO.	PART NUMBER	MATERIAL	COATING	QTY.
3	1/8-27	STEEL	ZINC PLATED	1
2	NA210-50MM	BEARING STEEL	N/A	1
1	P210	CAST IRON	POWDER COAT	1

SPECIFICATIONS	
UNITS:	IN (mm)
LOAD RATINGS	C: 7,400 LBS Co: 4,910 LBS
SPEED RATING	3300 RPM
GREASE TYPE	NLGI #2
GREASE FILL	45%
OPERATING TEMP	32°F - 200°F
SEAL TYPE	B-TYPE
INTERNAL CLEARANCE	C3
TORQUE SETTING ON SET SCREWS	

SOLVE
INDUSTRIAL MOTION GROUP

SIZE **B**
IPTCI
BEARINGS

DWG. NO.

WEIGHT	6.84
MATERIAL	SEE NOTES
COATING	SEE NOTES
DRAWN	SEC 12/16/2024
CHECKED	SEC 04/14/2025
APPROVED	
THIRD ANGLE PROJECTION	
PROPRIETARY AND CONFIDENTIAL	
THE INFORMATION CONTAINED IN THIS DRAWING IS THE SOLE PROPERTY OF SOLVE IMG. ANY REPRODUCTION IN PART OR AS A WHOLE WITHOUT THE WRITTEN PERMISSION OF SOLVE IMG IS PROHIBITED.	

DATE	BY	REVISION DESCRIPTION	REV
ITEM DESCRIPTION: NAP210-50MM			SCALE 1:7
			REV -

9 8 7 6 5 4 3 2 1