

**C QD Sheaves**

 Cast Iron Sheaves - Heavy Duty  
 Bushed, Three and Four Groove

For C &amp; CX V-Belts. See pages 118-119.

Order part number size

Example: 3C60SD

Order QD bushings separately

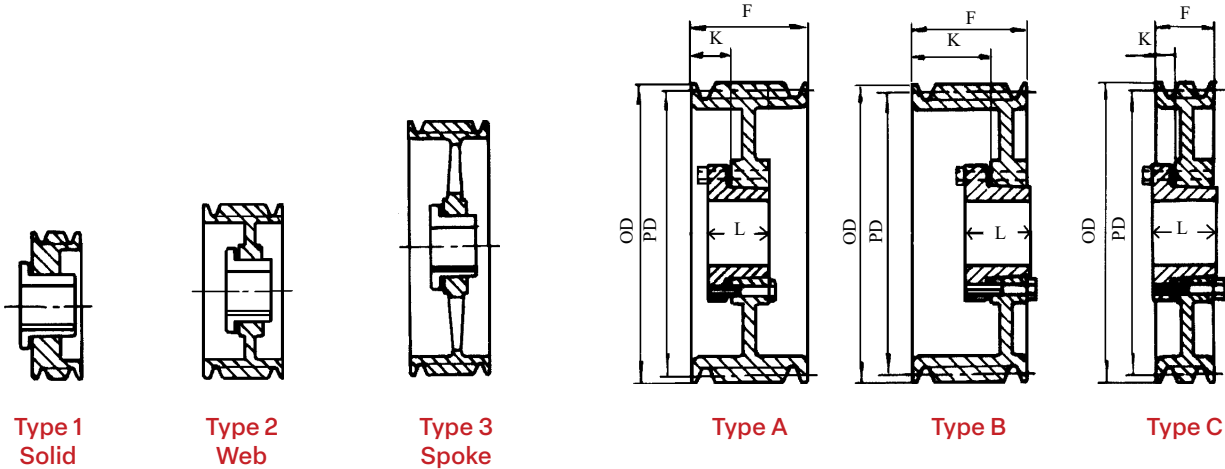
**Stock Bushings Located on Pages 84-85.**

Diameters		3 Groove F = 3 3/8						4 Groove F = 4 3/8					
O.D.	P.D.	Part No.	Bushing#	Type	K	L	WT.	Part No.	Bushing#	Type	K	L	WT.
5.40	5.00	3C50SD	SD	A-1	1 1/4	1 13/16	8.4	4C50SD	SD	A-1	1 1/4	1 13/16	10.2
5.40	5.00	^3C50SK	SK	A-1	0	1 15/16	8.4	^4C50SK	SK	A-1	0	1 15/16	10.2
5.80	5.40	3C54SD	SD	A-1	1 5/16	1 13/16	10.4	4C54SD	SD	A-1	1 5/16	1 13/16	11.8
5.90	5.50	3C55SD	SD	A-1	1 5/16	1 13/16	10.9	4C55SD	SD	A-1	1 5/16	1 13/16	13.5
5.90	5.50							^4C55SK	SK	A-1	0	1 15/16	13.0
6.00	5.60	3C56SD	SD	A-1	1 5/16	1 13/16	11.2	4C56SD	SD	A-1	1 5/16	1 13/16	13.9
6.40	6.00	3C60SF	SF	A-1	7/8	2 1/16	10.1	4C60SF	SF	A-1	7/8	2 1/16	12.0
6.90	6.50	*3C65SF	SF	A-1	0	2 1/16	10.8	*4C65SF	SF	A-1	13/16	2 1/16	12.2
7.40	7.00	3C70SF	SF	A-1	1 5/16	2 1/16	15.9	4C70SF	SF	A-1	1 9/16	2 1/16	18.0
7.90	7.50	3C75SF	SF	A-1	1 5/16	2 1/16	18.0	4C75SF	SF	A-1	1 9/16	2 1/16	20.5
8.40	8.00	3C80E	E	B-1	1 3/4	2 3/4	20.9	4C80E	E	A-1	2	2 3/4	24.0
8.90	8.50	3C85E	E	B-1	1 3/4	2 3/4	24.5	4C85E	E	A-1	2	2 3/4	27.3
9.40	9.00	3C90E	E	B-1	1 3/4	2 3/4	27.1	4C90E	E	A-1	2	2 3/4	30.7
9.90	9.50	3C95E	E	B-1	1 3/4	2 3/4	29.1	4C95E	E	A-1	2	2 3/4	34.9
10.40	10.00	3C100E	E	B-2	1 3/4	2 3/4	30.1	4C100E	E	A-2	2	2 3/4	38.1
10.90	10.50	3C105E	E	B-2	1 3/4	2 3/4	30.8	4C105E	E	A-2	2	2 3/4	35.8
11.40	11.00	3C110E	E	B-3	1 3/4	2 3/4	32.9	4C110E	E	A-3	2	2 3/4	38.4
12.40	12.00	3C120E	E	B-3	1 3/4	2 3/4	38.4	4C120E	E	A-3	2	2 3/4	43.6
13.40	13.00	3C130E	E	B-3	1 3/4	2 3/4	42.4	4C130E	E	A-3	2	2 3/4	49.4
14.40	14.00	3C140E	E	B-3	1 3/4	2 3/4	41.7	4C140E	E	A-3	2	2 3/4	50.7
15.40	15.00	3C150E	E	B-3	1 3/4	2 3/4	45.0	4C150E	E	A-3	2	2 3/4	52.0
16.40	16.00	3C160E	E	B-3	1 3/4	2 3/4	49.8	4C160E	E	A-3	2	2 3/4	60.2
18.40	18.00	3C180E	E	B-3	1 3/4	2 3/4	58.6	4C180E	E	A-3	2	2 3/4	68.6
20.40	20.00	3C200E	E	A-3	1	2 3/4	62.6	4C200E	E	A-3	1 1/2	2 3/4	76.9
24.40	24.00	3C240E	E	A-3	1	2 3/4	78.7	4C240F	F	A-3	1 5/16	3 3/4	100.4
27.40	27.00	3C270F	F	C-3	7/8	3 3/4	103.0	4C270F	F	A-3	1 5/16	3 3/4	116.8
30.40	30.00	3C300F	F	C-3	7/8	3 3/4	115.4	4C300F	F	A-3	1 5/16	3 3/4	136.1
36.40	36.00	3C360F	F	C-3	7/8	3 3/4	161.7	4C360F	F	A-3	1 5/16	3 3/4	194.2
44.40	44.00	3C440F	F	C-3	13/16	3 3/4	242.8	4C440J	J	A-3	1 9/16	4 5/8	270.4
50.40	50.00	3C500F	F	C-3	13/16	3 3/4	275.0	4C500J	J	A-3	1 9/16	4 5/8	337.4

**Note:** Cast iron sheaves may not exceed 6500 FPM. This speed **DOES NOT** specify if dynamic balancing (2 plane) is required. Contact customer service to verify whether dynamic balancing is required.

\* = Can only be mounted from one direction.  
 ^ = Small O.D. sheaves used heavily in the oil industry.  
 Can only be mounted from one direction.