

**A-B QD Sheaves**

 Cast Iron Sheaves - Heavy Duty  
 Bushed, Ten Groove

**For A, AX, B & BX V-Belts. See pages 111-117.**

Order part number size

Example: 10B34SH

Order QD bushings separately

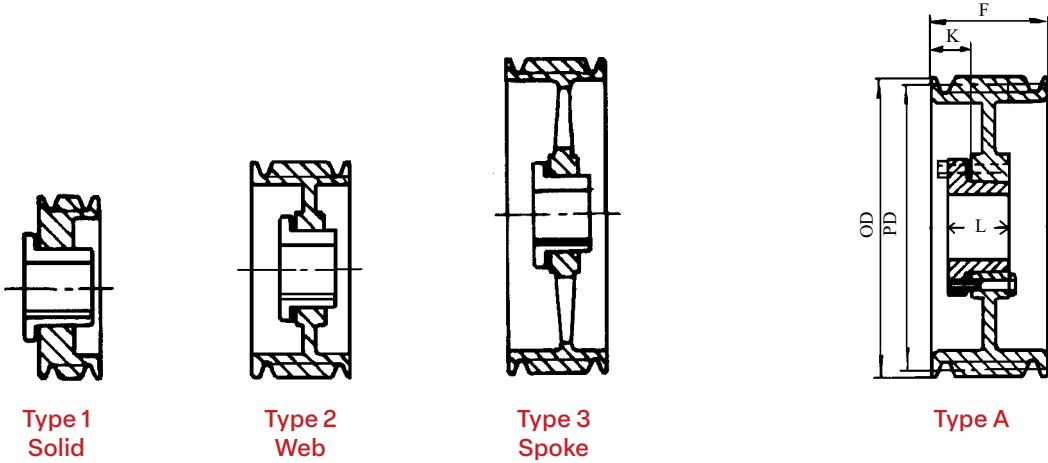
**Stock Bushings Located on Pages 84-85.**

O.D.	P.D.		10 Groove F = 7 3/4					WT.
	A	B		Bush	Type	K	L	
5.75	5.00	5.40	<b>10B54SK</b>	SK	A-1	2 9/16	1 15/16	18.5
5.95	5.20	5.60	<b>10B56SK</b>	SK	A-1	2 9/16	1 15/16	19.8
6.15	5.40	5.80	<b>10B58SK</b>	SK	A-1	2 9/16	1 15/16	21.2
6.35	5.60	6.00	<b>10B60SK</b>	SK	A-1	2 9/16	1 15/16	22.3
6.55	5.80	6.20	<b>10B62SF</b>	SF	A-1	2 9/16	2 1/16	22.8
6.75	6.00	6.40	<b>10B64SF</b>	SF	A-1	2 9/16	2 1/16	24.2
6.95	6.20	6.60	<b>10B66SF</b>	SF	A-1	2 9/16	2 1/16	25.6
7.15	6.40	6.80	<b>10B68SF</b>	SF	A-1	2 9/16	2 1/16	26.8
7.35	6.60	7.00	<b>10B70SF</b>	SF	A-1	2 9/16	2 1/16	28.3
7.75	7.00	7.40	<b>10B74SF</b>	SF	A-1	2 9/16	2 1/16	31.4
8.95	8.20	8.60	<b>10B86E</b>	E	A-1	3 1/8	2 3/4	41.0
9.75	9.00	9.40	<b>10B94E</b>	E	A-2	3 1/8	2 3/4	47.8
11.35	10.60	11.00	<b>10B110E</b>	E	A-2	3 1/8	2 3/4	58.0
12.75	12.00	12.40	<b>10B124E</b>	E	A-3	3 1/8	2 3/4	65.0
13.95	13.20	13.60	<b>10B136F</b>	F	A-3	2 1/16	3 3/4	80.0
15.75	15.00	15.40	<b>10B154F</b>	F	A-3	2 1/16	3 3/4	87.0
16.35	15.60	16.00	<b>10B160F</b>	F	A-3	2 1/16	3 3/4	89.0
18.75	18.00	18.40	<b>10B184F</b>	F	A-3	2 1/16	3 3/4	102.0
20.35	19.60	20.00	<b>10B200F</b>	F	A-3	2 1/16	3 3/4	112.0
25.35	24.60	25.00	<b>10B250F</b>	F	A-3	2 1/16	3 3/4	148.0
30.35	29.60	30.00	<b>10B300F</b>	F	A-3	2 1/16	3 3/4	188.0
38.35	37.60	38.00	<b>10B380J</b>	J	A-3	1 9/16	4 5/8	291.0

**Note:** Cast iron sheaves may not exceed 6500 FPM. This speed **DOES NOT** specify if dynamic balancing (2 plane) is required. Contact customer service to verify whether dynamic balancing is required.