

3V QD Sheaves

Cast Iron Sheaves - Heavy Duty
Bushed, Ten Groove

For 3V & 3VX V-Belts. See pages 120-121.

Order part number size

Example: 10/3V475SK

Order QD bushings separately

**Stock Bushings Located on
Pages 84-85.**

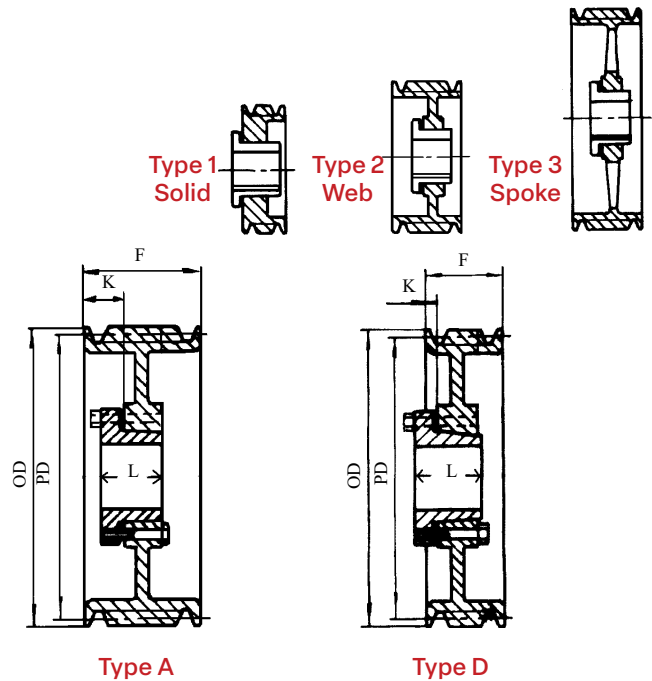

Diameters		10 Groove F = 4 11/32					
O.D.	P.D.	Part No.	Bush	Type	K	L	WT.
4.75	4.70	*10/3V475SK	SK	D-1	1/8	1 15/16	6.9
5.00	4.95	*10/3V500SK	SK	D-1	1/8	1 15/16	8.1
5.30	5.25	10/3V530SK	SK	A-1	1 7/16	1 15/16	8.8
5.60	5.55	10/3V560SK	SK	A-1	1 7/16	1 15/16	10.1
6.00	5.95	10/3V600SK	SK	A-1	1 7/16	1 15/16	13.8
6.50	6.45	10/3V650SK	SK	A-1	1 7/16	1 15/16	13.7
6.90	6.85	10/3V690SK	SK	A-2	1 7/16	1 15/16	14.1
8.00	7.95	10/3V800SF	SF	A-2	1 1/2	2 1/16	18.1
10.60	10.55	10/3V1060E	E	A-3	1 1/4	2 3/4	29.2
14.00	13.95	10/3V1400E	E	A-3	1 1/4	2 3/4	37.0
19.00	18.95	10/3V1900E	E	A-3	1 1/4	2 3/4	54.0
25.00	24.95	10/3V2500F	F	A-3	1 5/16	3 3/4	90.0
33.50	33.45	10/3V3350F	F	A-3	1 5/16	3 3/4	178.0

* = Can only be mounted from one direction.

Note: Cast iron sheaves may not exceed 6500 FPM. This speed **DOES NOT** specify if dynamic balancing (2 plane) is required. Contact customer service to verify whether dynamic balancing is required.