

### 5V QD Sheaves

Cast Iron Sheaves - Heavy Duty  
Bushed, Six and Seven Groove

For 5V & 5VX V-Belts. See pages 120, 122, & 123.



Order part number size

Example: 6/5V440SD

Order QD bushings separately  
**Stock Bushings Located on  
Pages 84-85.**

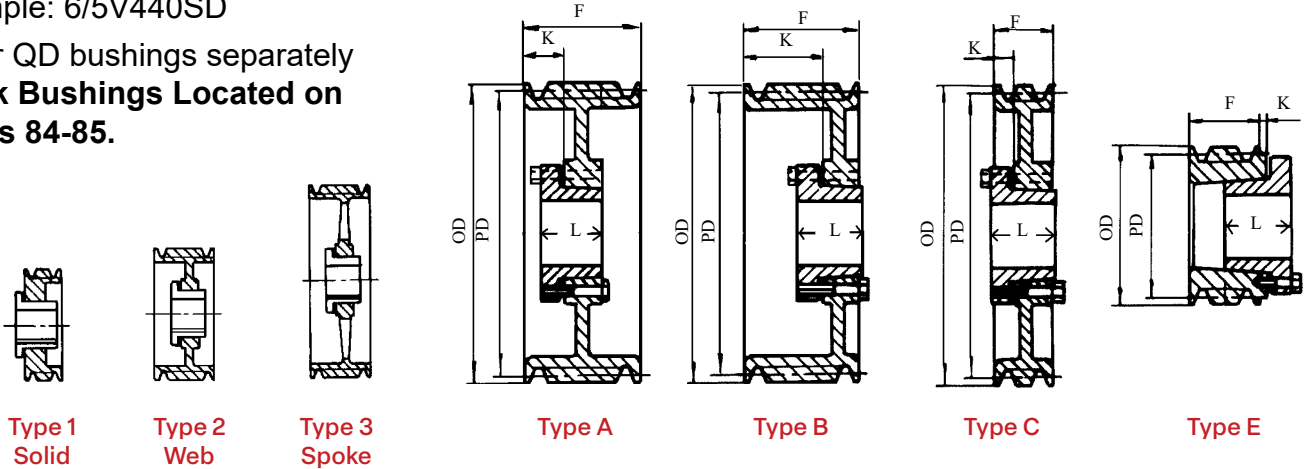

Type 1  
Solid

Type 2  
Web

Type 3  
Spoke

Type A

Type B

Type C

Type E

Diameters		6 Groove F = 4 7/16						7 Groove F = 5 1/8					
O.D.	P.D.	Part No.	Bush	Type	K	L	WT.	Part No.	Bush	Type	K	L	WT.
4.40	4.30	*6/5V440SD	SD	E-1	0	1 13/16	7.7						
4.65	4.55	*6/5V465SD	SD	E-1	0	1 13/16	8.1						
4.90	4.80	6/5V490SD	SD	A-1	1 5/16	1 13/16	8.1						
5.20	5.10	6/5V520SD	SD	A-1	1 5/16	1 13/16	10.5						
5.50	5.40	6/5V550SD	SD	A-1	1 5/16	1 13/16	12.0						
5.90	5.80	6/5V590SK	SK	A-1	1 5/16	1 15/16	12.6						
6.30	6.20	6/5V630SK	SK	A-1	1 5/16	1 15/16	14.5						
6.70	6.60	6/5V670SF	SF	A-1	1 5/8	2 1/16	15.4						
7.10	7.00	6/5V710SF	SF	A-1	1 5/8	2 1/16	17.4	7/5V710SF	SF	A-1	2 1/8	2 1/16	17.7
7.50	7.40	6/5V750SF	SF	A-1	1 5/8	2 1/16	19.4	7/5V750SF	SF	A-1	2 1/8	2 1/16	20.1
8.00	7.90	6/5V800E	E	A-1	2	2 3/4	22.7	7/5V800E	E	A-1	2 1/2	2 3/4	23.8
8.50	8.40	6/5V850E	E	A-1	2	2 3/4	26.0	7/5V850E	E	A-1	2 1/2	2 3/4	26.5
9.00	8.90	6/5V900E	E	A-1	2	2 3/4	29.4	7/5V900E	E	A-1	2 1/2	2 3/4	32.0
9.25	9.15	6/5V925E	E	A-1	2	2 3/4	30.8	7/5V925E	F	A-1	2 9/16	3 3/4	37.5
9.75	9.65	6/5V975E	E	A-2	2	2 3/4	35.0	7/5V975E	F	A-1	2 9/16	3 3/4	43.0
10.30	10.20	6/5V1030E	E	A-2	2	2 3/4	33.0	7/5V1030F	F	A-1	2 9/16	3 3/4	44.3
10.90	10.80	6/5V1090E	E	A-2	2	2 3/4	35.6	7/5V1090F	F	A-2	2 9/16	3 3/4	45.5
11.30	11.20	6/5V1130E	E	A-2	2	2 3/4	36.7	7/5V1130F	F	A-2	2 9/16	3 3/4	47.0
11.80	11.70	6/5V1180E	E	A-2	2	2 3/4	41.4	7/5V1180F	F	A-2	2 9/16	3 3/4	50.0
12.50	12.40	6/5V1250F	F	B-2	15/16	3 3/4	45.2	7/5V1250F	F	A-2	2 9/16	3 3/4	53.3
13.20	13.10	6/5V1320F	F	B-2	15/16	3 3/4	50.0	7/5V1320F	F	A-2	2 9/16	3 3/4	56.0
14.00	13.90	6/5V1400F	F	B-2	15/16	3 3/4	52.6	7/5V1400F	F	A-2	2 9/16	3 3/4	60.5
15.00	14.90	6/5V1500F	F	B-3	15/16	3 3/4	55.2	7/5V1500F	F	A-2	2 9/16	3 3/4	65.0
16.00	15.90	6/5V1600F	F	B-3	1 15/16	3 3/4	58.0	7/5V1600F	F	A-2	2 9/16	3 3/4	71.0
18.70	18.60	6/5V1870F	F	A-3	1 5/16	3 3/4	70.0						
21.20	21.10	6/5V2120F	F	A-3	1 5/16	3 3/4	81.0						
23.60	23.50	6/5V2360J	J	B-3	1 1/4	4 5/8	117.5						
28.00	27.90	6/5V2800J	J	B-3	1 1/4	4 5/8	125.0						
31.50	31.40	6/5V3150J	J	B-3	1 1/4	4 5/8	200.0						
37.50	37.40	6/5V3750J	J	B-3	1 1/4	4 5/8	235.0						
50.00	49.90	6/5V5000M	M	C-3	3/4	6 3/4	330.0						

**Note:** Cast iron sheaves may not exceed 6500 FPM. This speed **DOES NOT** specify if dynamic balancing (2 plane) is required. Contact customer service to verify whether dynamic balancing is required.

\* = Can only be mounted from one direction.