

2

1

B

B

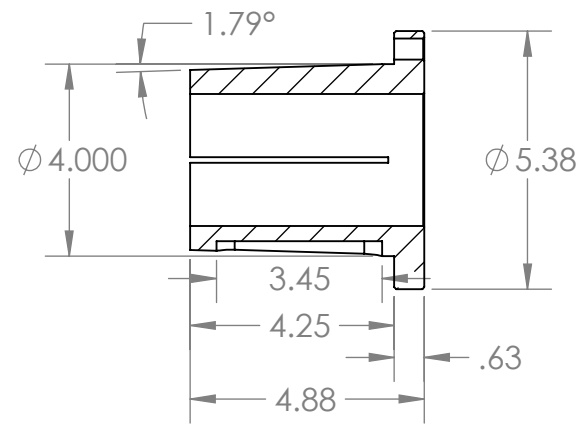
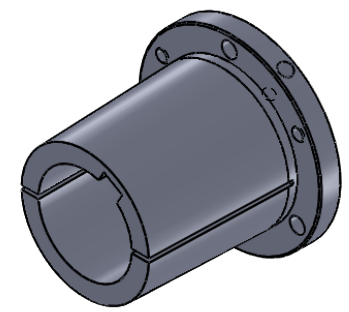

SECTION A-A

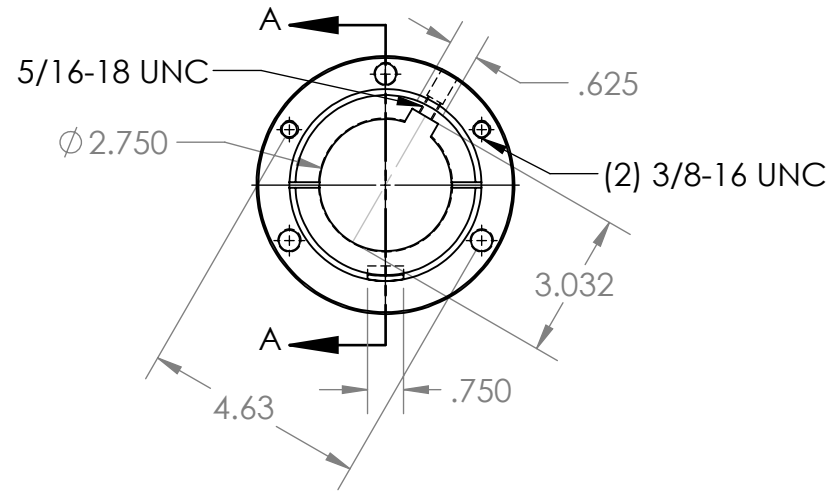

A

A

<p>PROPRIETARY AND CONFIDENTIAL THE INFORMATION CONTAINED IN THIS DRAWING IS THE SOLE PROPERTY OF MASTERDRIVE, INC. ANY REPRODUCTION IN PART OR AS A WHOLE WITHOUT THE WRITTEN PERMISSION OF MASTERDRIVE, INC. IS PROHIBITED.</p>					NAME	DATE	<p>MASTERDRIVE[®] POWER TRANSMISSION PRODUCTS</p> <p>TITLE: R2-2.3/4</p>		
					DRAWN	EDG 01/25/21			
					CHECKED				
					ENG APPR.				
					MFG APPR.				
					Q.A.				
					COMMENTS:				
							SIZE	DWG. NO.	REV
							A	R2-2.750	
							SCALE: 1:4	WEIGHT:	SHEET 1 OF 1

2

1

INTERPRET GEOMETRIC TOLERANCING PER:
MATERIAL
QT450-10 (Ductile Iron)
FINISH
Black Phosphate

NEXT ASSY

USED ON

APPLICATION

DO NOT SCALE DRAWING