

2

1

B

B

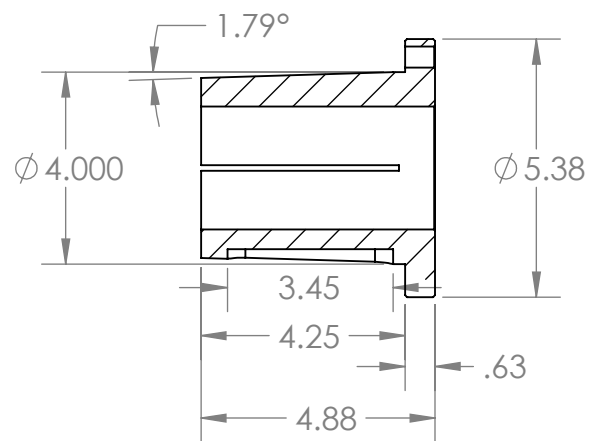
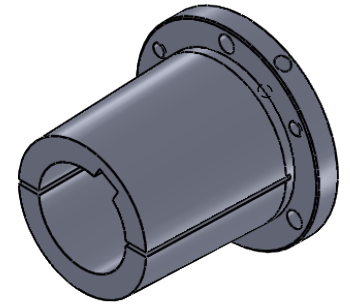

SECTION A-A

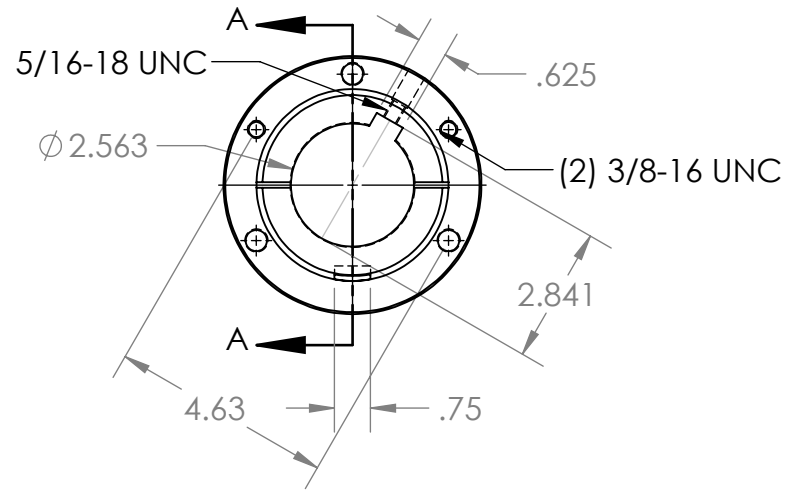

A

A

PROPRIETARY AND CONFIDENTIAL
 THE INFORMATION CONTAINED IN THIS DRAWING IS THE SOLE PROPERTY OF MASTERDRIVE, INC. ANY REPRODUCTION IN PART OR AS A WHOLE WITHOUT THE WRITTEN PERMISSION OF MASTERDRIVE, INC. IS PROHIBITED.

| | | | | | |
|-------------|---------|--------------------------------------|-------------------------|------|----------|
| | | | | NAME | DATE |
| | | | DRAWN | EDG | 01/25/21 |
| | | | CHECKED | | |
| | | | ENG APPR. | | |
| | | | MFG APPR. | | |
| | | | Q.A. | | |
| | | | COMMENTS: | | |
| | | INTERPRET GEOMETRIC TOLERANCING PER: | | | |
| | | MATERIAL | QT450-10 (Ductile Iron) | | |
| | | FINISH | Black Phosphate | | |
| NEXT ASSY | USED ON | | | | |
| APPLICATION | | DO NOT SCALE DRAWING | | | |



TITLE:
R2-2.9/16

SIZE **A** DWG. NO. **R2-2.563** REV

SCALE: 1:4 WEIGHT: SHEET 1 OF 1

2

1