

2

1

B

B

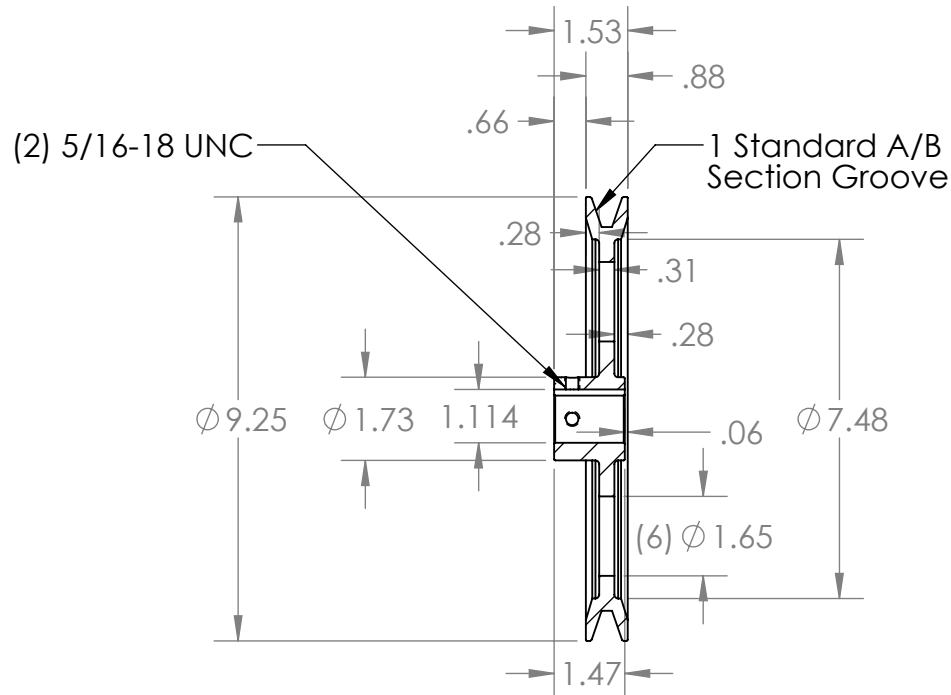

SECTION A-A

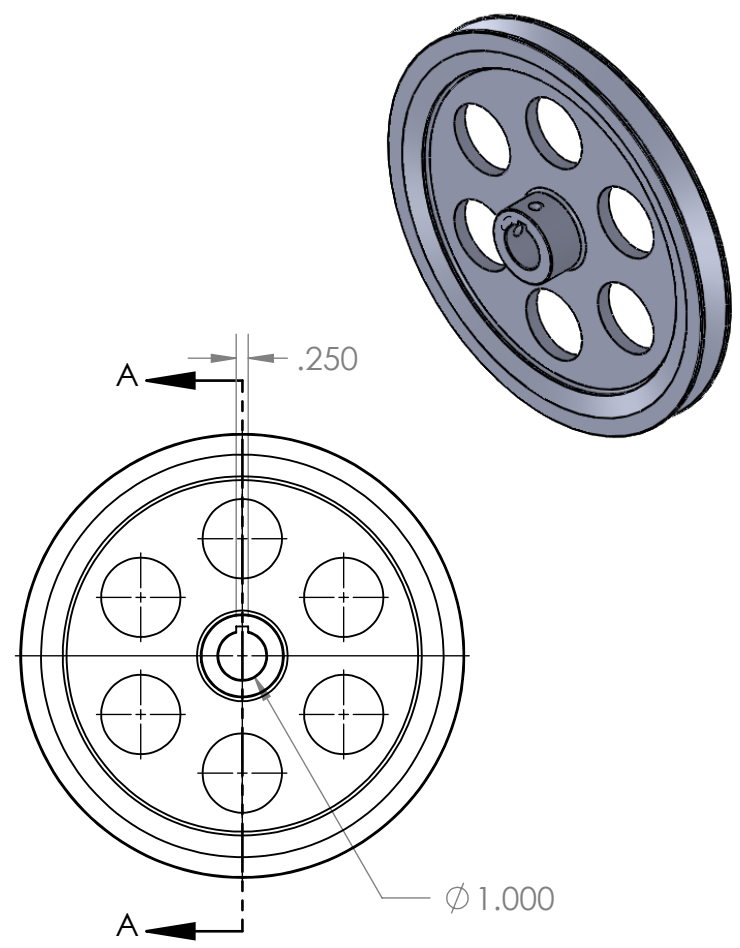

A

A

PROPRIETARY AND CONFIDENTIAL
 THE INFORMATION CONTAINED IN THIS DRAWING IS THE SOLE PROPERTY OF MASTERDRIVE, INC. ANY REPRODUCTION IN PART OR AS A WHOLE WITHOUT THE WRITTEN PERMISSION OF MASTERDRIVE, INC. IS PROHIBITED.

			INTERPRET GEOMETRIC TOLERANCING PER:	NAME	DATE
			MATERIAL	EDG	05/25/21
			HT200 (Cast Iron)		
			FINISH		
			Grey Paint		
NEXT ASSY	USED ON			COMMENTS:	
APPLICATION			DO NOT SCALE DRAWING		



TITLE:		
BK95-1		
SIZE	DWG. NO.	REV
A	BK95-1.000	
SCALE: 1:4	WEIGHT:	SHEET 1 OF 1

2

1