

2

1

B

B

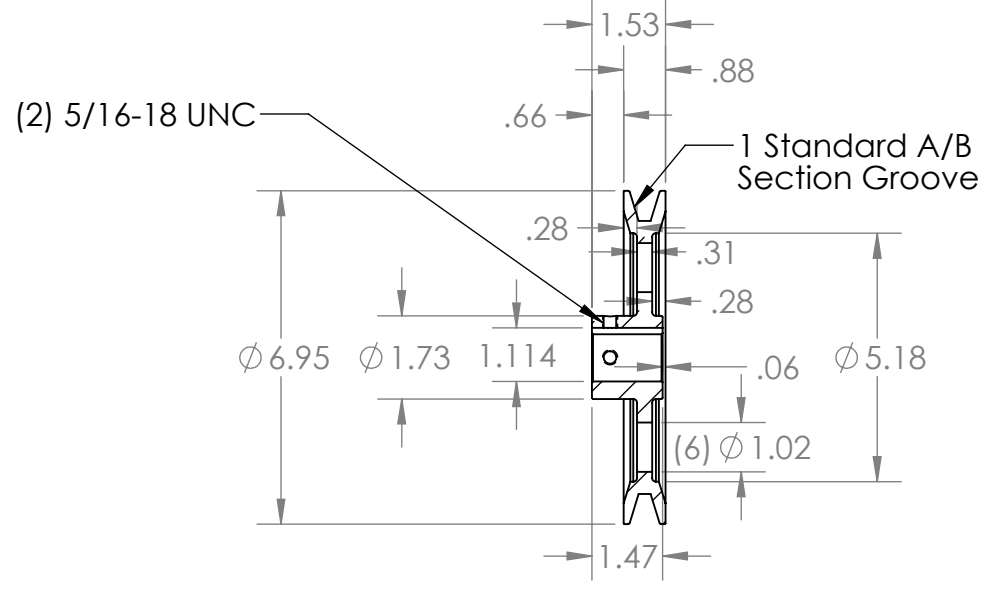
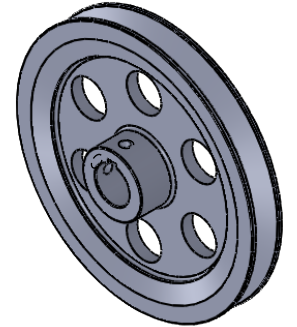

SECTION A-A

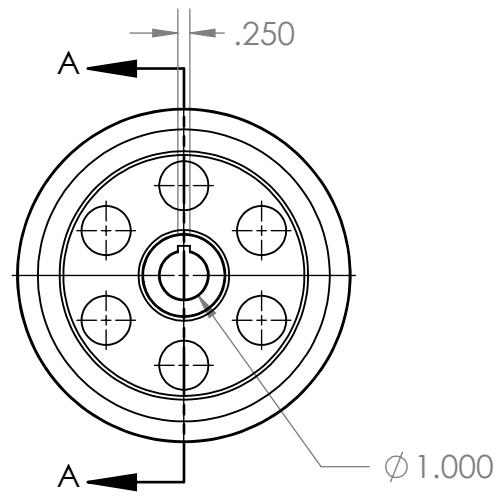

A

A

<p>PROPRIETARY AND CONFIDENTIAL THE INFORMATION CONTAINED IN THIS DRAWING IS THE SOLE PROPERTY OF MASTERDRIVE, INC. ANY REPRODUCTION IN PART OR AS A WHOLE WITHOUT THE WRITTEN PERMISSION OF MASTERDRIVE, INC. IS PROHIBITED.</p>					NAME	DATE			
					DRAWN	EDG 05/19/21			
					CHECKED			TITLE:	
					ENG APPR.			BK72-1	
					MFG APPR.			SIZE	DWG. NO.
					Q.A.		A	BK72-1.000	
					COMMENTS:		SCALE: 1:4	WEIGHT:	SHEET 1 OF 1
	NEXT ASSY	USED ON	FINISH	INTERPRET GEOMETRIC TOLERANCING PER:					
			Grey Paint	MATERIAL					
				HT200 (Cast Iron)					
	APPLICATION		DO NOT SCALE DRAWING						

2

1