

4

3

2

1

B

B

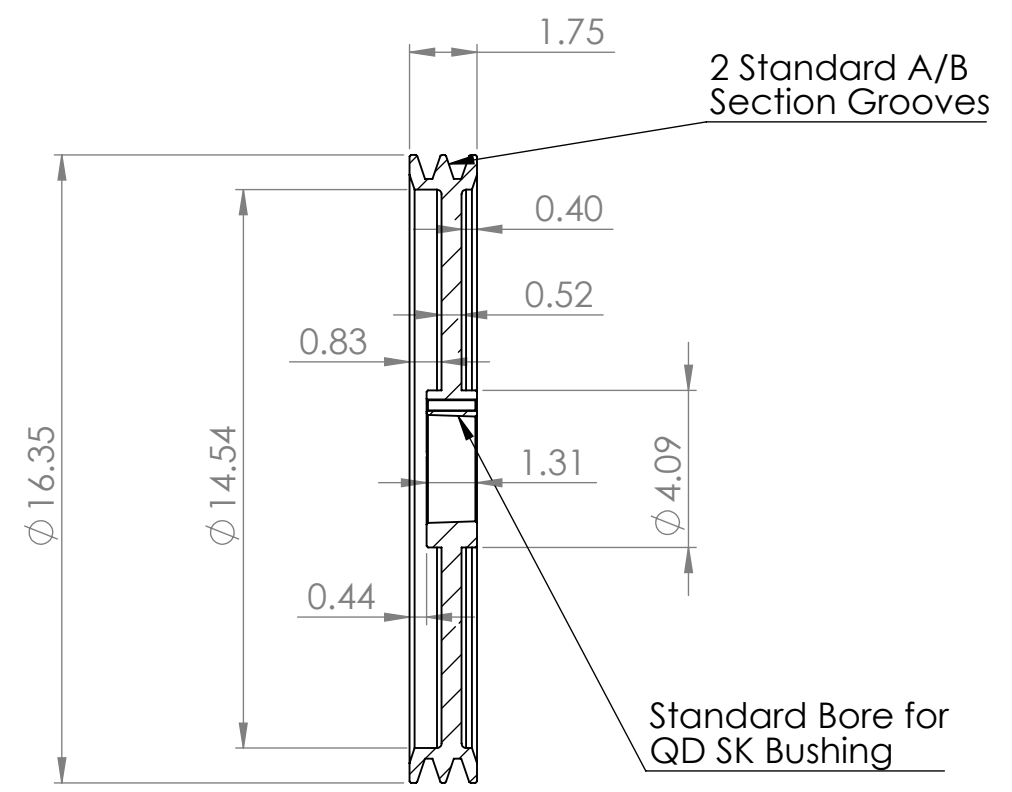

SECTION A-A

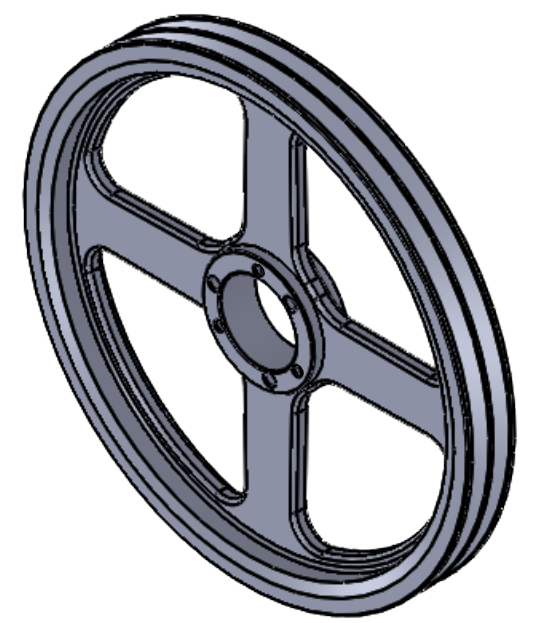
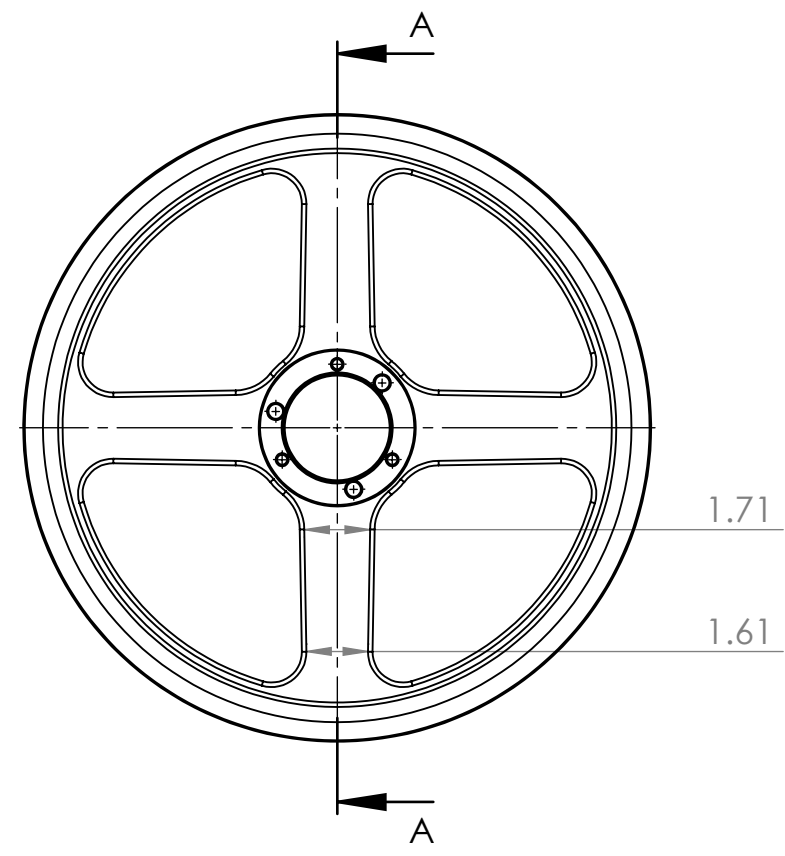

A

A

PROPRIETARY AND CONFIDENTIAL
 THE INFORMATION CONTAINED IN THIS DRAWING IS THE SOLE PROPERTY OF MASTERDRIVE, INC. ANY REPRODUCTION IN PART OR AS A WHOLE WITHOUT THE WRITTEN PERMISSION OF MASTERDRIVE, INC. IS PROHIBITED.

			NAME	DATE			
			DRAWN	EDG 08/24/18			
			CHECKED				
			ENG APPR.				
			MFG APPR.				
			Q.A.		TITLE:		
			COMMENTS:		2B160SK		
			INTERPRET GEOMETRIC TOLERANCING PER:		SIZE	DWG. NO.	REV
			MATERIAL		B	2B160SK	
			FINISH		SCALE: 1:5	WEIGHT:	SHEET 1 OF 1
			Grey Paint				
			APPLICATION	DO NOT SCALE DRAWING			

4

3

2

1