

B

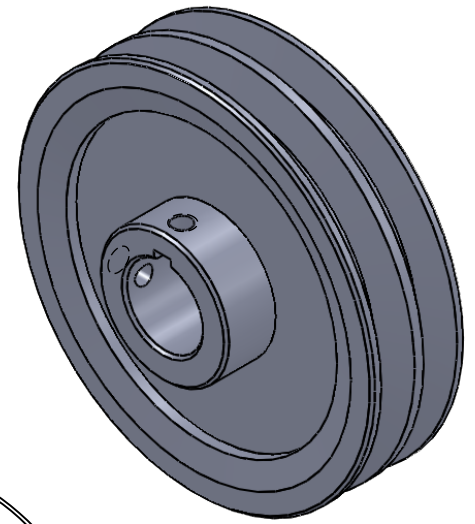
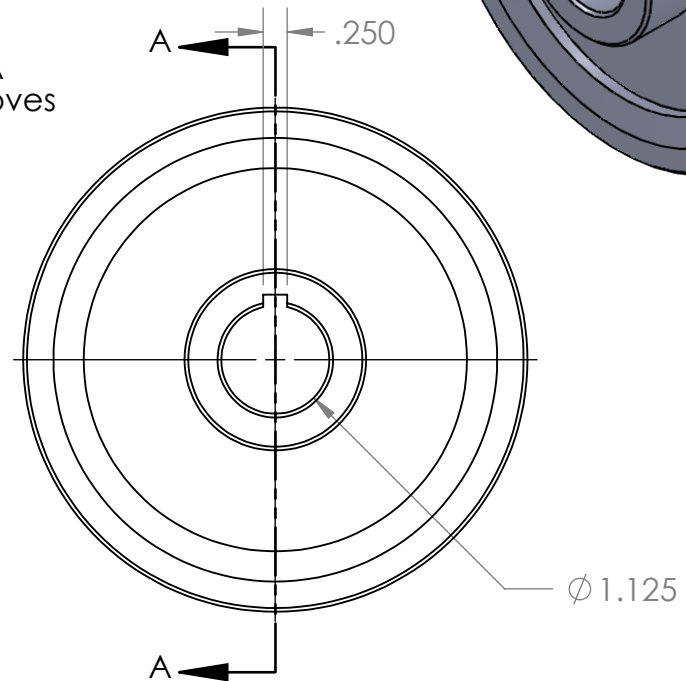
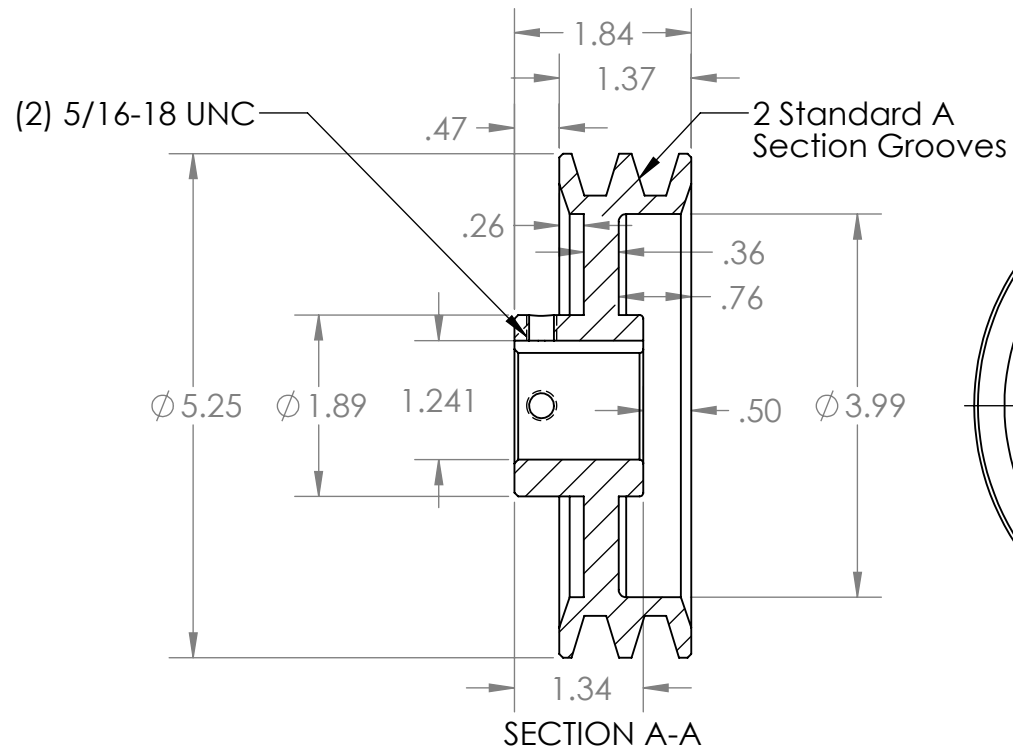

B

A

A

**PROPRIETARY AND CONFIDENTIAL**  
 THE INFORMATION CONTAINED IN THIS DRAWING IS THE SOLE PROPERTY OF MASTERDRIVE, INC. ANY REPRODUCTION IN PART OR AS A WHOLE WITHOUT THE WRITTEN PERMISSION OF MASTERDRIVE, INC. IS PROHIBITED.

NEXT ASSY

USED ON

APPLICATION

INTERPRET GEOMETRIC TOLERANCING PER:

MATERIAL  
HT200 (Cast Iron)FINISH  
Grey Paint

DO NOT SCALE DRAWING

DRAWN

CHECKED

ENG APPR.

MFG APPR.

Q.A.

COMMENTS:

NAME

EDG

DATE

04/13/21

**MASTERDRIVE**  
 POWER TRANSMISSION PRODUCTS

TITLE:

2AK54-1-1/8

SIZE

A

DWG. NO.

2AK54-1.125

REV

SCALE: 1:2

WEIGHT:

SHEET 1 OF 1

2

1