

2

1

B

B

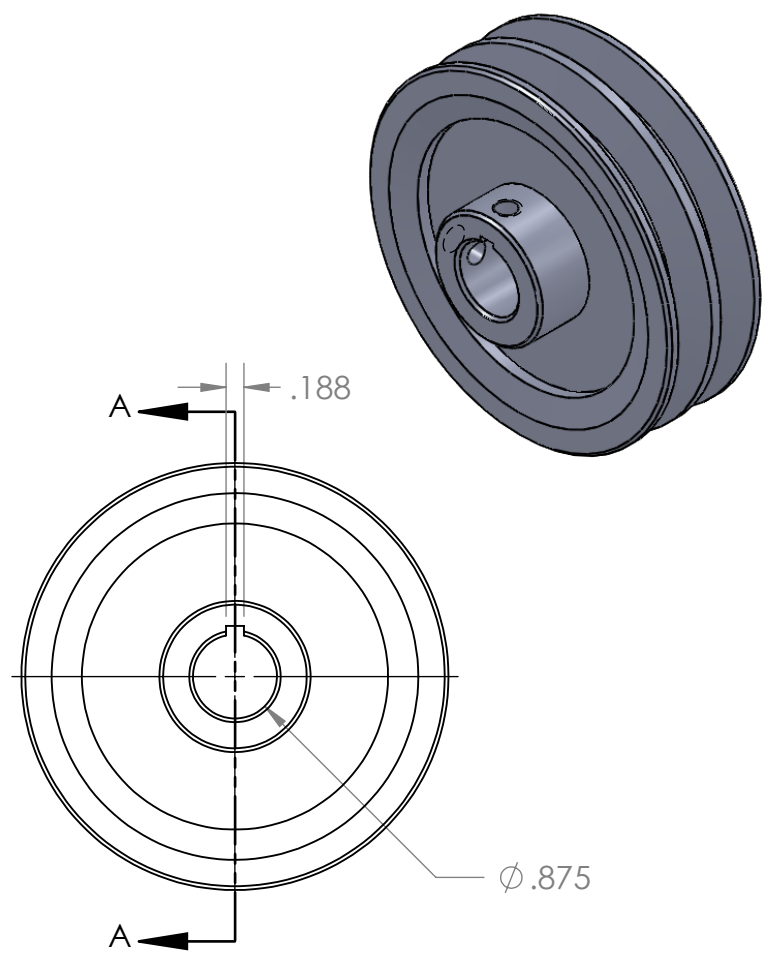
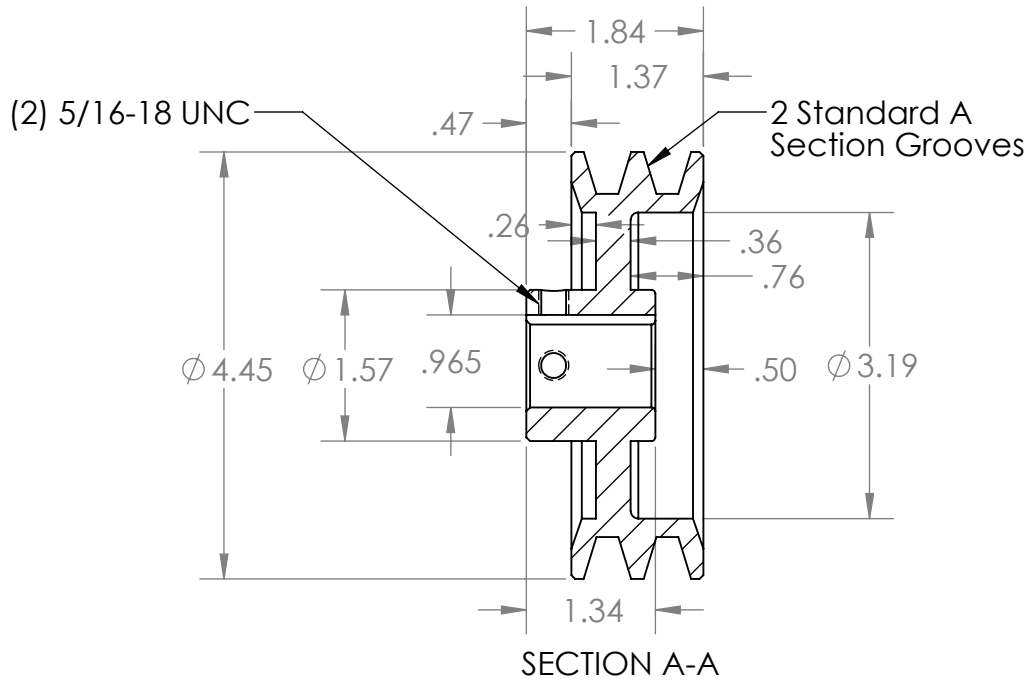

A

A

<p><b>PROPRIETARY AND CONFIDENTIAL</b></p> <p>THE INFORMATION CONTAINED IN THIS DRAWING IS THE SOLE PROPERTY OF MASTERDRIVE, INC. ANY REPRODUCTION IN PART OR AS A WHOLE WITHOUT THE WRITTEN PERMISSION OF MASTERDRIVE, INC. IS PROHIBITED.</p>					NAME	DATE	<p><b>MASTERDRIVE</b> </p> <p><b>POWER TRANSMISSION PRODUCTS</b></p> <p>TITLE:</p> <p><b>2AK46-7/8</b></p>		
					DRAWN	EDG 04/12/21			
					CHECKED				
					ENG APPR.				
					MFG APPR.				
					Q.A.				
					COMMENTS:				
							SIZE	DWG. NO.	REV
	NEXT ASSY	USED ON		INTERPRET GEOMETRIC TOLERANCING PER:			<b>A</b>	<b>2AK46-0.875</b>	
				MATERIAL			SCALE: 1:2	WEIGHT:	SHEET 1 OF 1
				FINISH					
	APPLICATION			Grey Paint					
				DO NOT SCALE DRAWING					

2

1