

B

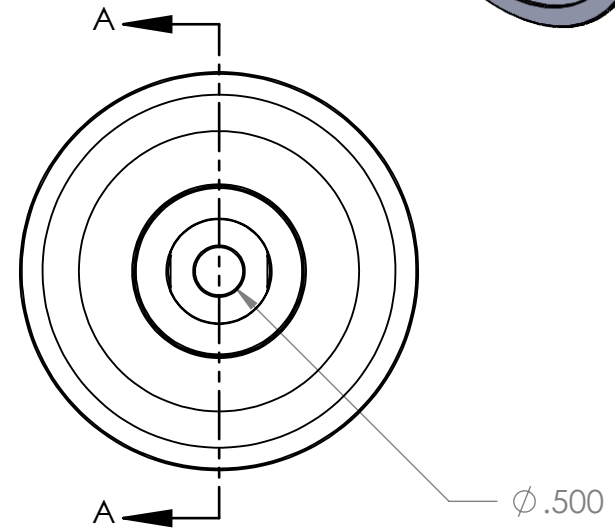
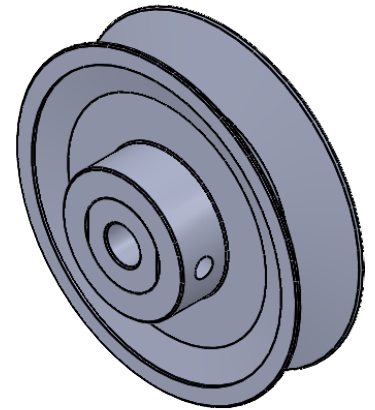
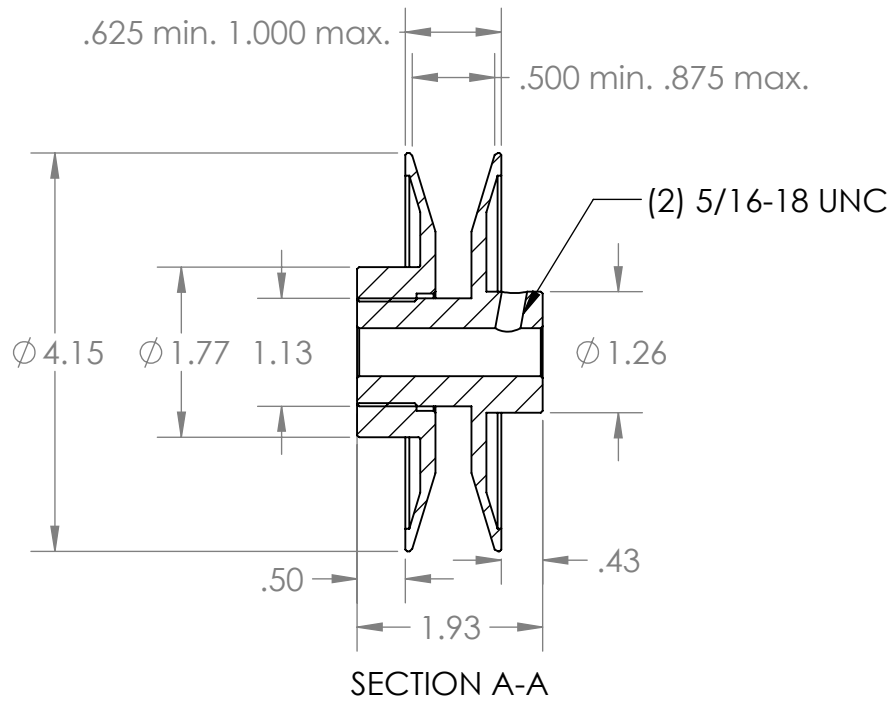

B

A

A

PROPRIETARY AND CONFIDENTIAL
 THE INFORMATION CONTAINED IN THIS DRAWING IS THE SOLE PROPERTY OF MASTERDRIVE, INC. ANY REPRODUCTION IN PART OR AS A WHOLE WITHOUT THE WRITTEN PERMISSION OF MASTERDRIVE, INC. IS PROHIBITED.

NEXT ASSY

USED ON

APPLICATION

INTERPRET GEOMETRIC TOLERANCING PER:

MATERIAL
HT200 (Cast Iron)FINISH
Grey Paint

DO NOT SCALE DRAWING

DRAWN

NAME

EDG

DATE

08/05/21

CHECKED

ENG APPR.

MFG APPR.

Q.A.

COMMENTS:

MASTERDRIVE[®]
 POWER TRANSMISSION PRODUCTS

TITLE:

1VL44-1/2

SIZE

A

DWG. NO.

1VL44-0.500

REV

SCALE: 1:2

WEIGHT:

SHEET 1 OF 1

2

1