

2

1

B

B

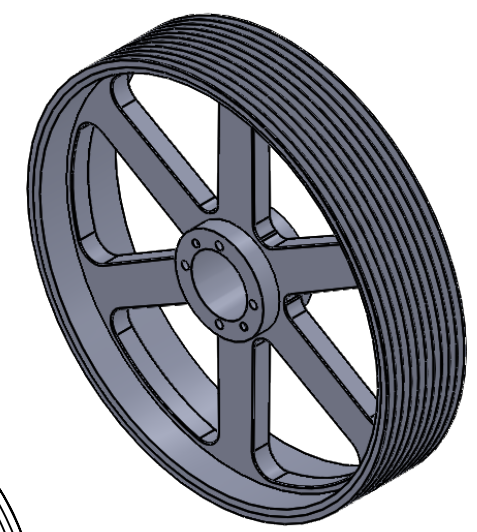
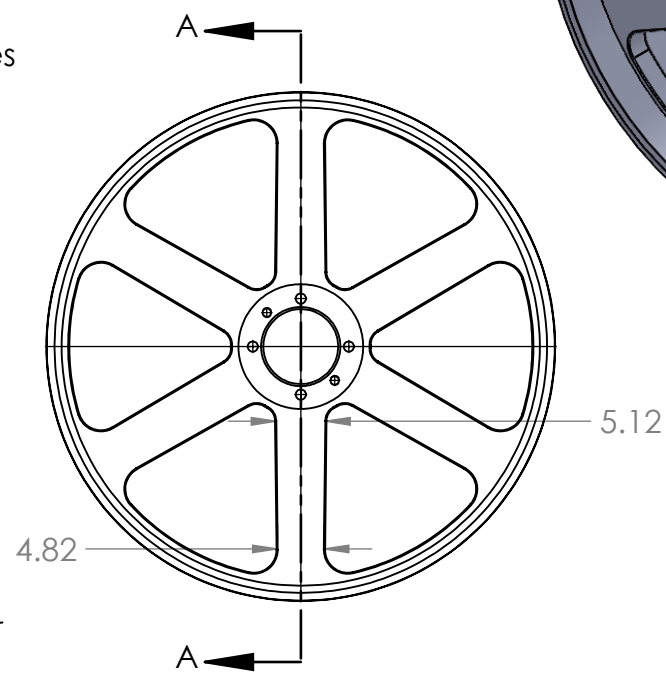
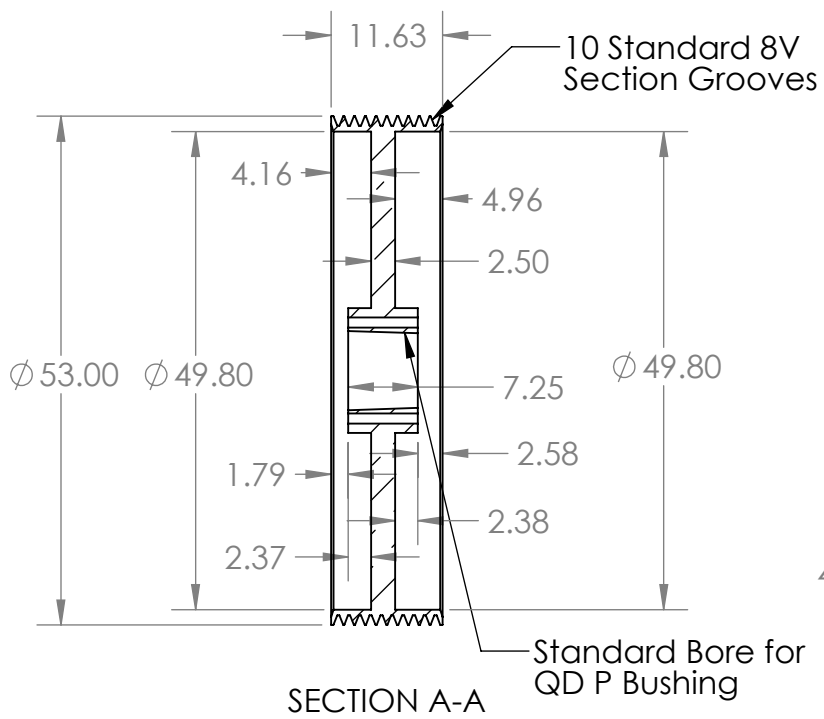

A

A

**PROPRIETARY AND CONFIDENTIAL**  
 THE INFORMATION CONTAINED IN THIS DRAWING IS THE SOLE PROPERTY OF <INSERT COMPANY NAME HERE>. ANY REPRODUCTION IN PART OR AS A WHOLE WITHOUT THE WRITTEN PERMISSION OF <INSERT COMPANY NAME HERE> IS PROHIBITED.

				NAME	DATE
				DRAWN	EDG 02/17/20
				CHECKED	
				ENG APPR.	
				MFG APPR.	
				Q.A.	
				COMMENTS:	
				INTERPRET GEOMETRIC TOLERANCING PER:	
				MATERIAL	
				HT200 (Cast Iron)	
				FINISH	
				Grey Paint	
				APPLICATION	
				DO NOT SCALE DRAWING	



TITLE:  
**10/8V5300P**

SIZE DWG. NO. REV  
**A 108V5300P**

SCALE: 1:20 WEIGHT: SHEET 1 OF 1

2

1