

9 8 7 6 5 4 3 2 1

G F E D C B A

G F E D C B A

G F E D C B A

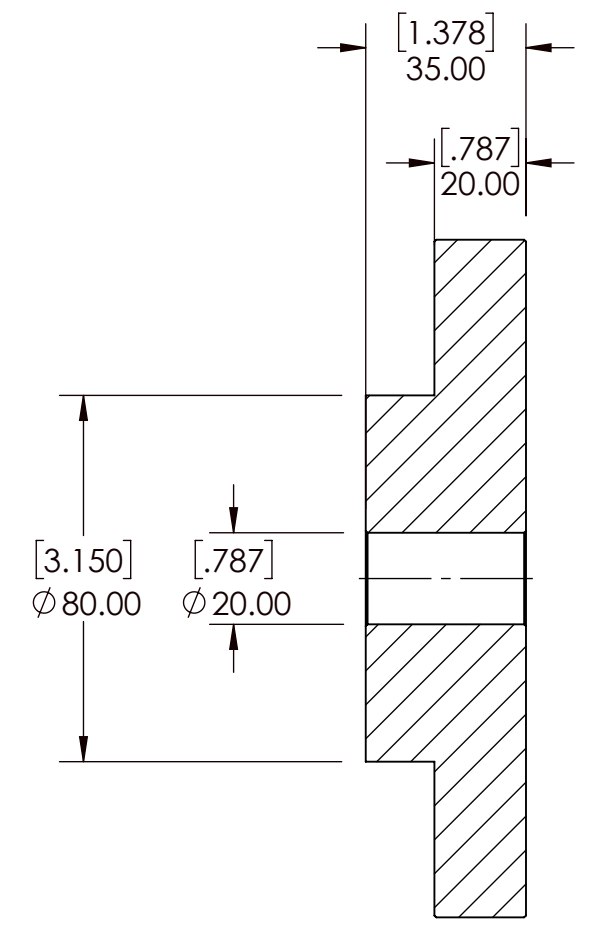
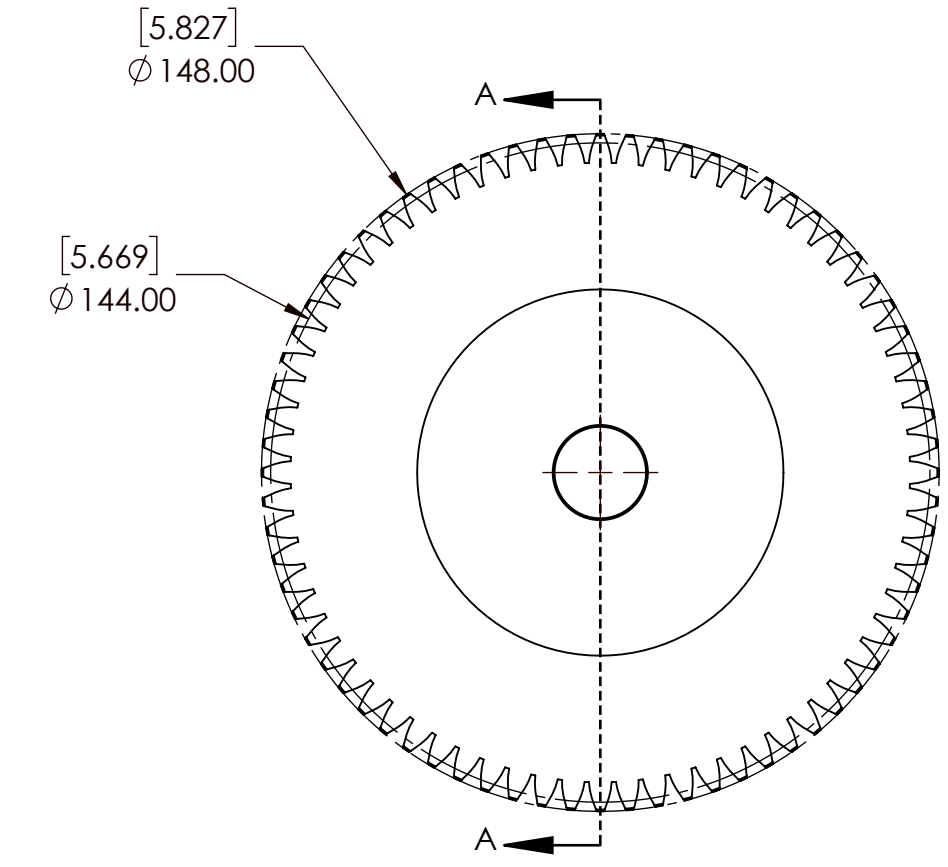

SECTION A-A

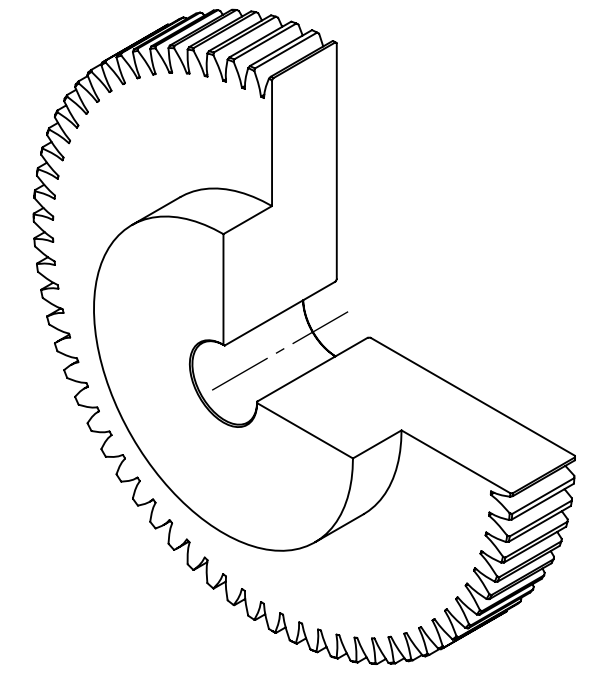

SPUR GEAR SPECIFICATIONS		WEIGHT		DATE		BY		REVISION DESCRIPTION		REV
UNITS	mm (INCH)	6.63 LBS								
MODULE	2	STEEL								
PRESSURE ANGLE	20°	N/A								
NUMBER OF TEETH	72	DRAWN SEC 08/28/2025								
PITCH DIAMETER	144mm	CHECKED SEC 08/28/2025								
HUB TYPE	B	APPROVED								
MAX TORQUE (Nm)	135.00 Nm	THIRD ANGLE PROJECTION								
TOOTH TYPE	STRAIGHT	DWG. NO.								
MAX RIM SPEED	12 M/S	PROPRIETARY AND CONFIDENTIAL								
		PTI		ITEM DESCRIPTION:		M2B72		SCALE		
								1:1		
								REV		
								-		

9 8 7 6 5 4 3 2 1

A

A