

9 8 7 6 5 4 3 2 1

G

F

E

D

C

B

A

9 8 7 6 5 4 3 2 1

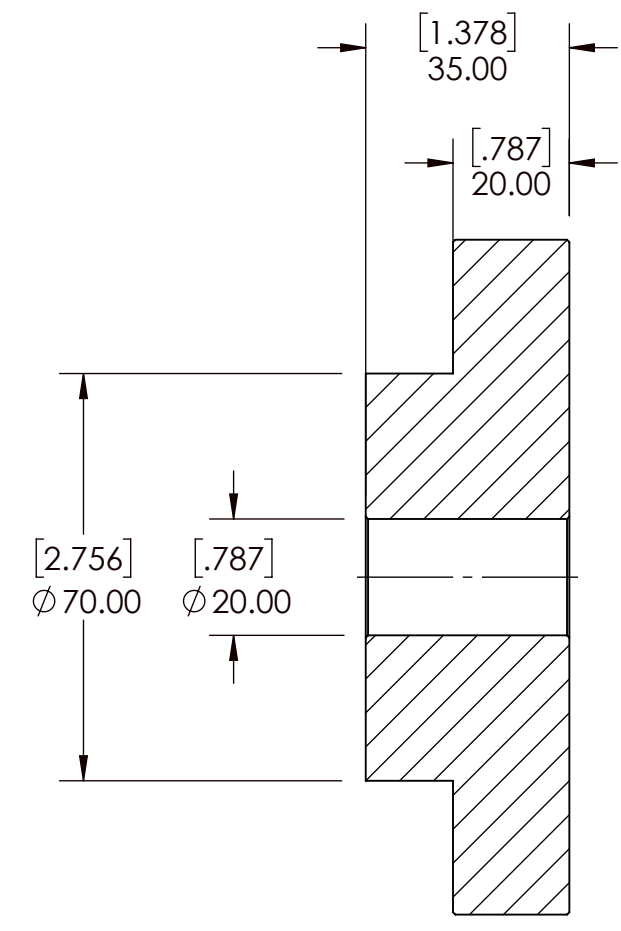
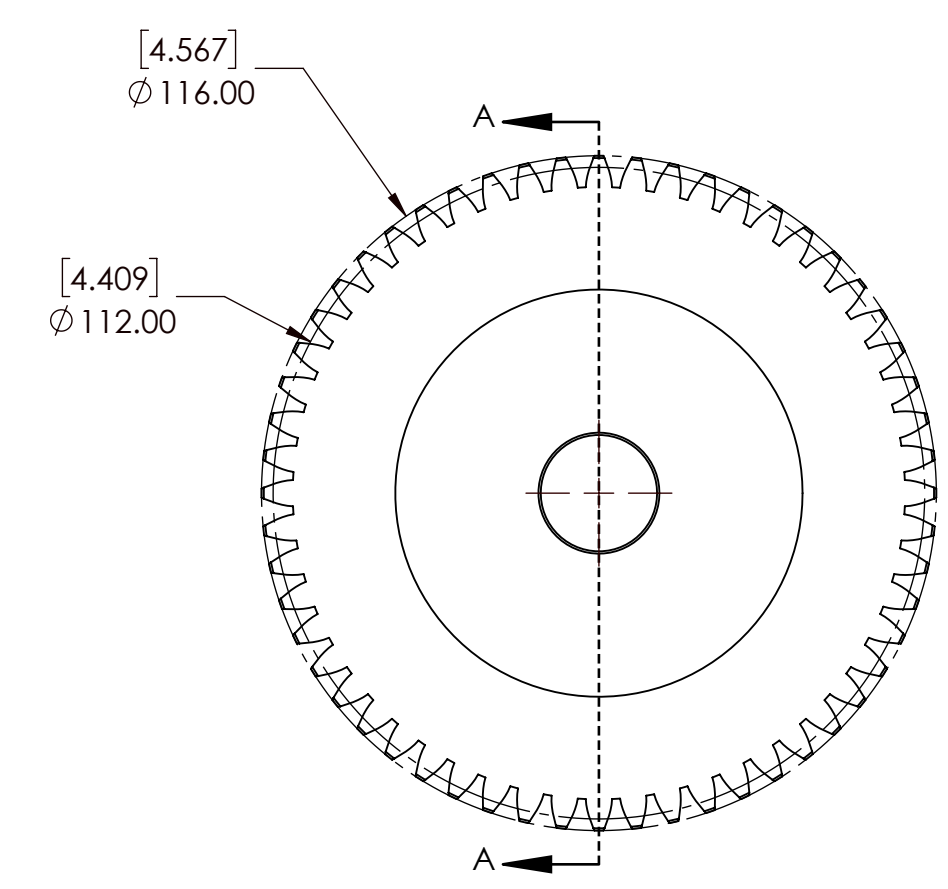

SECTION A-A

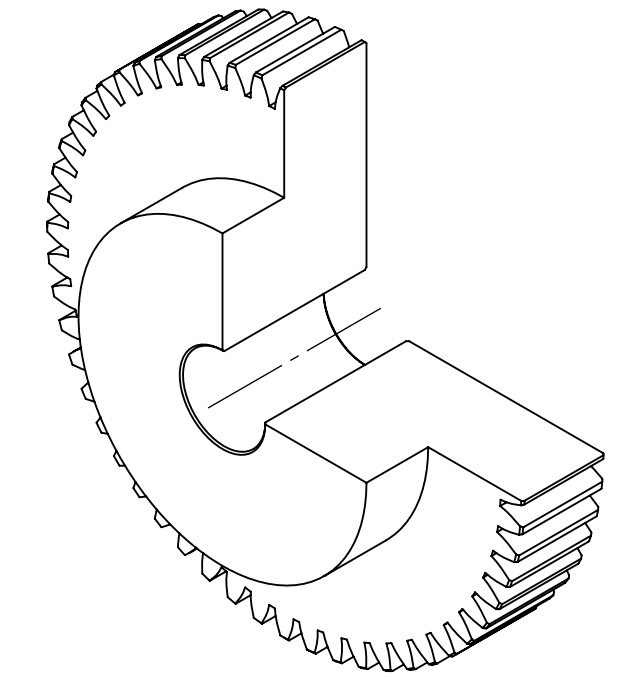

SPUR GEAR SPECIFICATIONS		WEIGHT		DATE		BY		REVISION DESCRIPTION		REV
UNITS	mm (INCH)	4.15 LBS								
MODULE	2	STEEL								
PRESSURE ANGLE	20°	N/A								
NUMBER OF TEETH	56	DRAWN	SEC	08/28/2025						
PITCH DIAMETER	112mm	CHECKED	SEC	08/28/2025						
HUB TYPE	B	APPROVED								
MAX TORQUE (Nm)	80.50 Nm	THIRD ANGLE PROJECTION								
TOOTH TYPE	STRAIGHT	DWG. NO.		ITEM DESCRIPTION:		M2B56		SCALE	1:1	
MAX RIM SPEED	12 M/S	PROPRIETARY AND CONFIDENTIAL		DATE		BY		REV	-	
		THE INFORMATION CONTAINED IN THIS DRAWING IS THE SOLE PROPERTY OF SOLVE IMG. ANY REPRODUCTION IN PART OR AS A WHOLE WITHOUT THE WRITTEN PERMISSION OF SOLVE IMG IS PROHIBITED.								

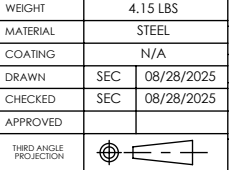

PROPRIETARY AND CONFIDENTIAL
THE INFORMATION CONTAINED IN THIS DRAWING IS THE SOLE PROPERTY OF SOLVE IMG. ANY REPRODUCTION IN PART OR AS A WHOLE WITHOUT THE WRITTEN PERMISSION OF SOLVE IMG IS PROHIBITED.

M2B56

SCALE 1:1
REV -