

SECTION A-A

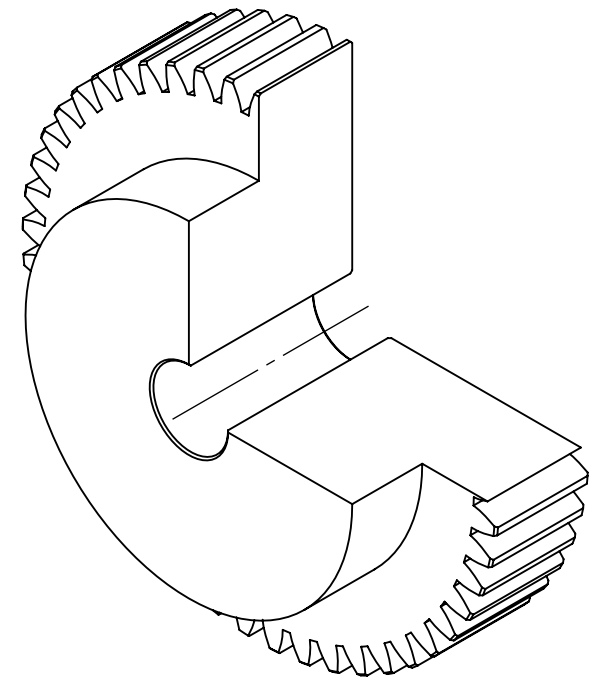

SPUR GEAR SPECIFICATIONS		WEIGHT		DATE		BY		REVISION DESCRIPTION		REV
UNITS	mm (INCH)	3.44 LBS								
MODULE	2	STEEL								
PRESSURE ANGLE	20°	N/A								
NUMBER OF TEETH	49	DRAWN	SEC	08/28/2025						
PITCH DIAMETER	98mm	CHECKED	SEC	08/28/2025						
HUB TYPE	B	APPROVED								
MAX TORQUE (Nm)	54.20 Nm	THIRD ANGLE PROJECTION		ITEM DESCRIPTION:		M2B49		SCALE	1:1	
TOOTH TYPE	STRAIGHT	DWG. NO.		DATE		BY		REV	-	
MAX RIM SPEED	12 M/S	PTI		PROPRIETARY AND CONFIDENTIAL		THE INFORMATION CONTAINED IN THIS DRAWING IS THE SOLE PROPERTY OF SOLVE IMG. ANY REPRODUCTION IN PART OR AS A WHOLE WITHOUT THE WRITTEN PERMISSION OF SOLVE IMG IS PROHIBITED.				