

9 8 7 6 5 4 3 2 1

G F E D C B A

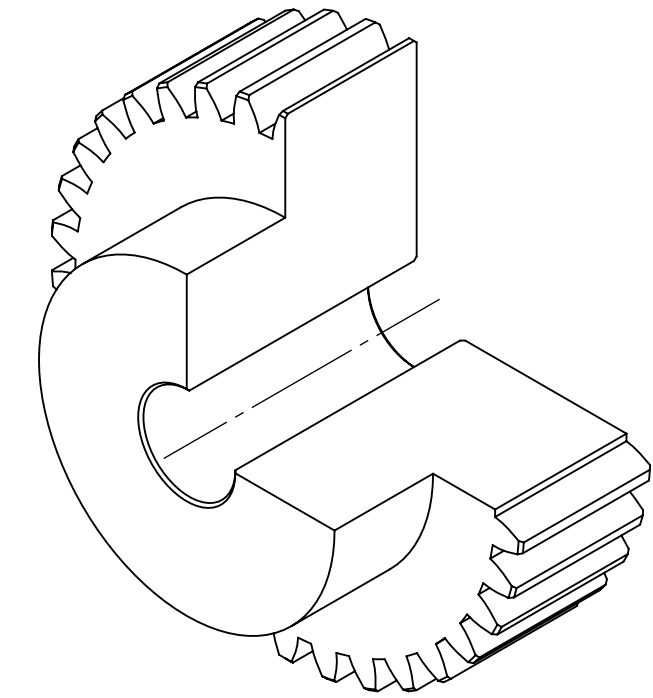
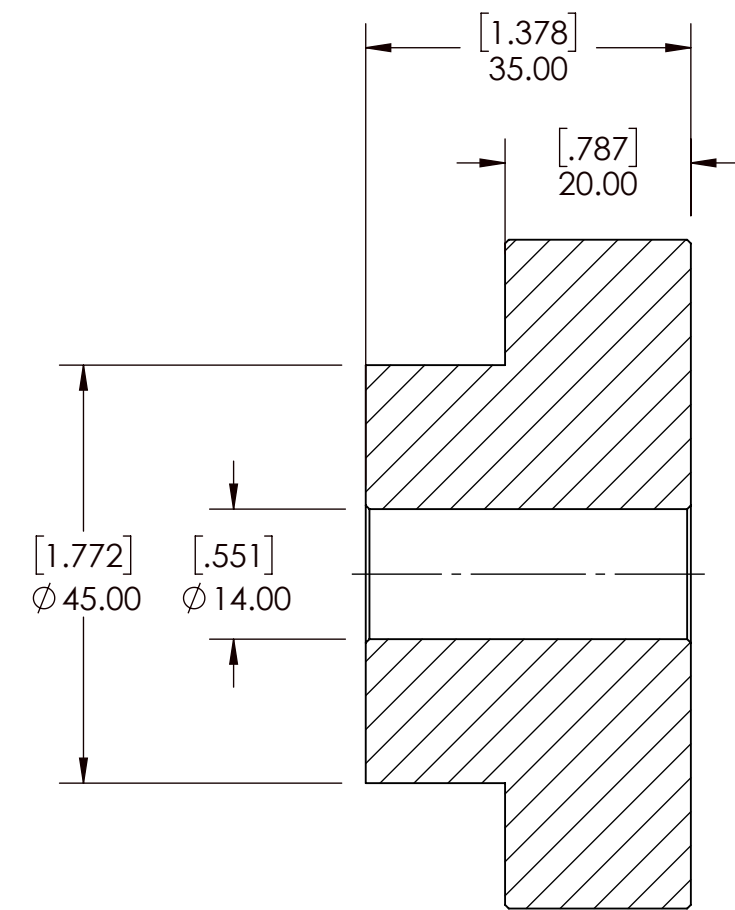
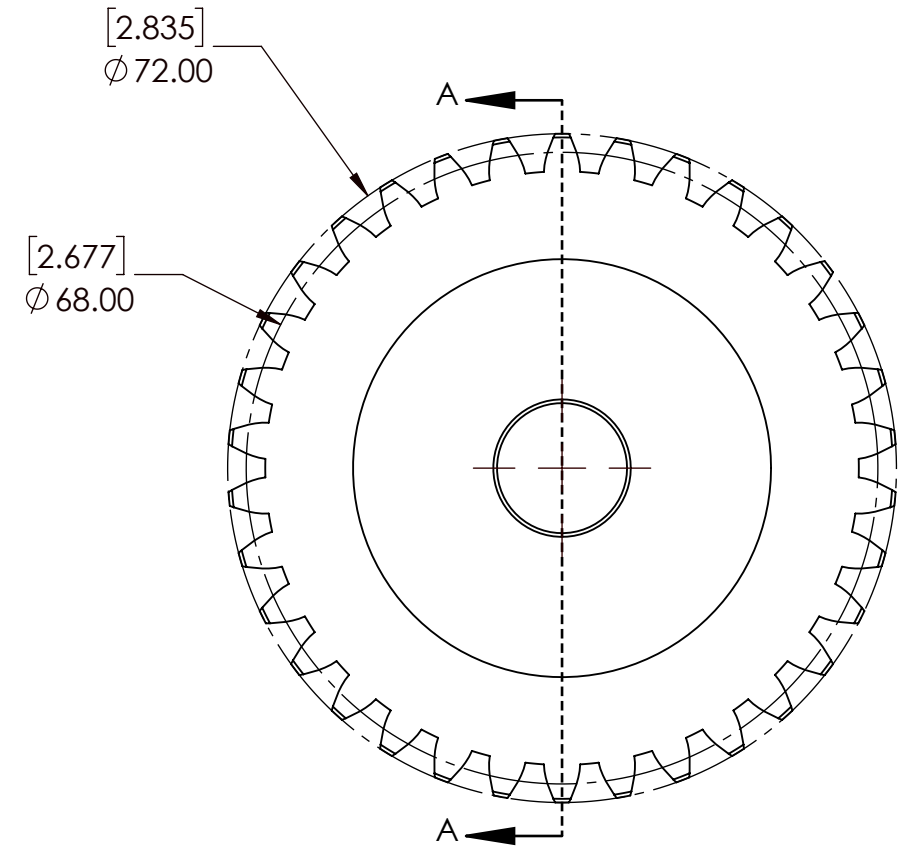

SECTION A-A

SPUR GEAR SPECIFICATIONS		WEIGHT		1.56 LBS	
UNITS	mm (INCH)	MATERIAL	STEEL		
MODULE	2	COATING	N/A		
PRESSURE ANGLE	20°	DRAWN	SEC	08/28/2025	
NUMBER OF TEETH	34	CHECKED	SEC	08/28/2025	
PITCH DIAMETER	68mm	APPROVED			
HUB TYPE	B	THIRD ANGLE PROJECTION			
MAX TORQUE (Nm)	22.20 Nm	DATE	BY	REVISION DESCRIPTION	
TOOTH TYPE	STRAIGHT	ITEM DESCRIPTION:		M2B34	REV
MAX RIM SPEED	12 M/S	DWG. NO.			SCALE
		<small>PROPRIETARY AND CONFIDENTIAL</small> <small>THE INFORMATION CONTAINED IN THIS DRAWING IS THE SOLE PROPERTY OF SOLVE IMG. ANY REPRODUCTION IN PART OR AS A WHOLE WITHOUT THE WRITTEN PERMISSION OF SOLVE IMG IS PROHIBITED.</small>			1:1
					REV
					-

9 8 7 6 5 4 3 2 1

A B C D E F G