

9 8 7 6 5 4 3 2 1

G F E D C B A

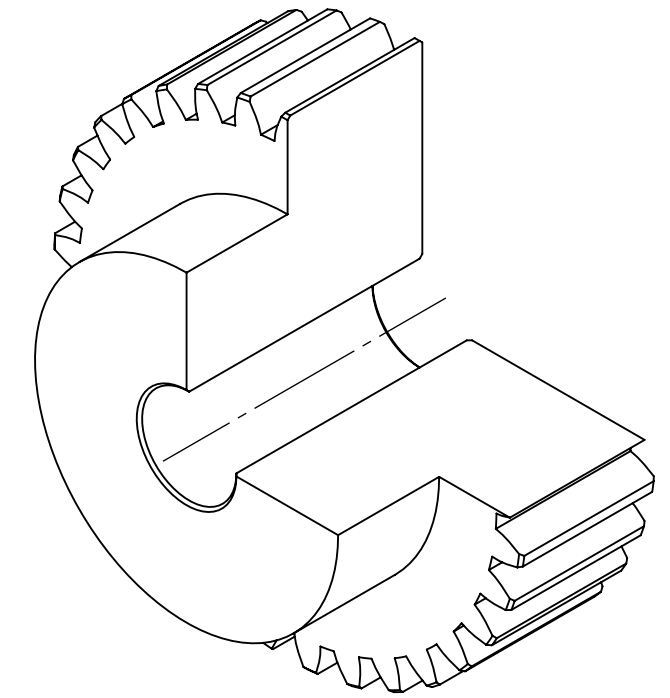
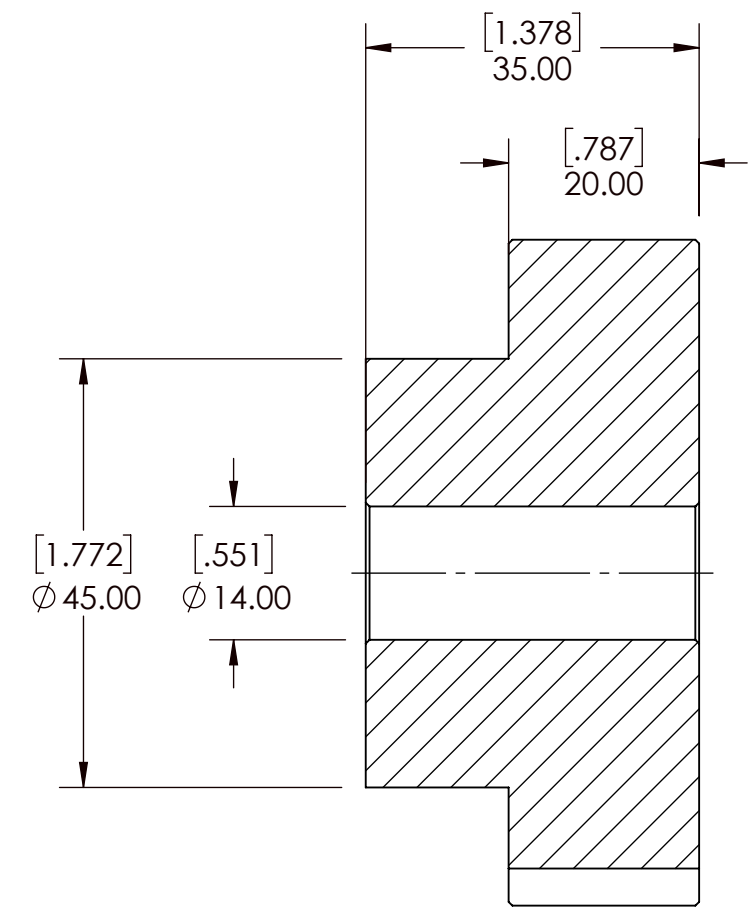
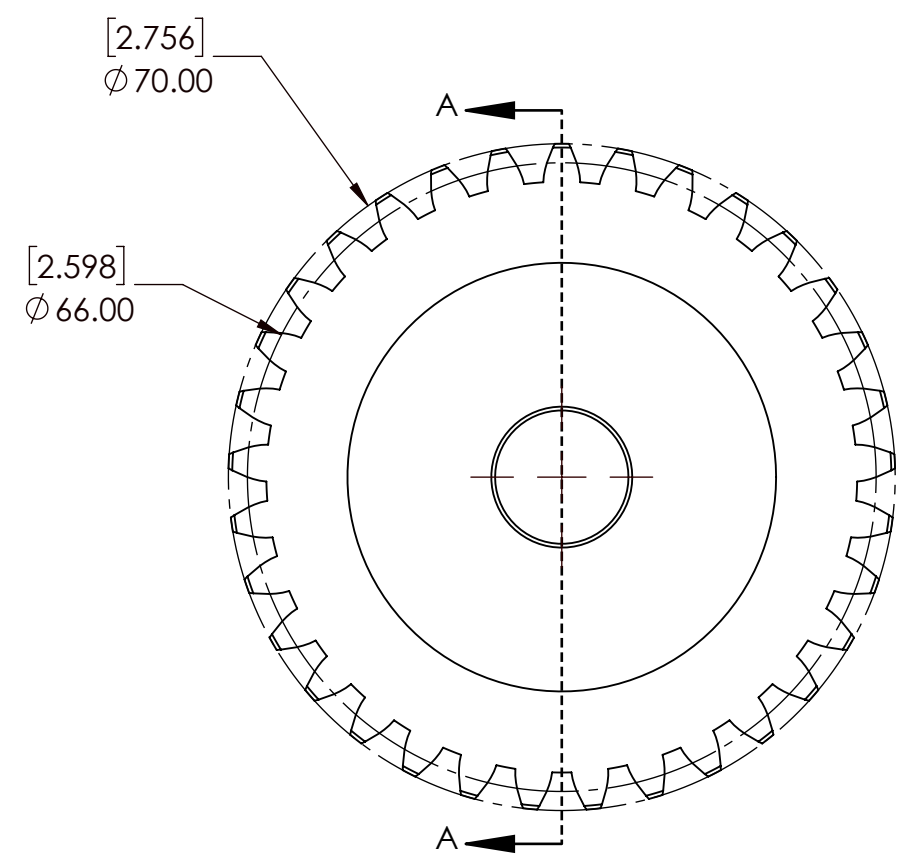

SECTION A-A

SPUR GEAR SPECIFICATIONS		WEIGHT		DATE		BY		REVISION DESCRIPTION		REV
UNITS	mm (INCH)	1.49 LBS								
MODULE	2	STEEL								
PRESSURE ANGLE	20°	N/A								
NUMBER OF TEETH	33	DRAWN	SEC	08/28/2025						
PITCH DIAMETER	66mm	CHECKED	SEC	08/28/2025						
HUB TYPE	B	APPROVED								
MAX TORQUE (Nm)	20.80 Nm	THIRD ANGLE PROJECTION								
TOOTH TYPE	STRAIGHT	DWG. NO.								
MAX RIM SPEED	12 M/S	M2B33								
		PROPRIETARY AND CONFIDENTIAL								
		THE INFORMATION CONTAINED IN THIS DRAWING IS THE SOLE PROPERTY OF SOLVE IMG. ANY REPRODUCTION IN PART OR AS A WHOLE WITHOUT THE WRITTEN PERMISSION OF SOLVE IMG IS PROHIBITED.								
		SCALE								
		1:1								
		REV								
		-								

9 8 7 6 5 4 3 2 1

A B C D E F G