

9 8 7 6 5 4 3 2 1

G F E D C B A

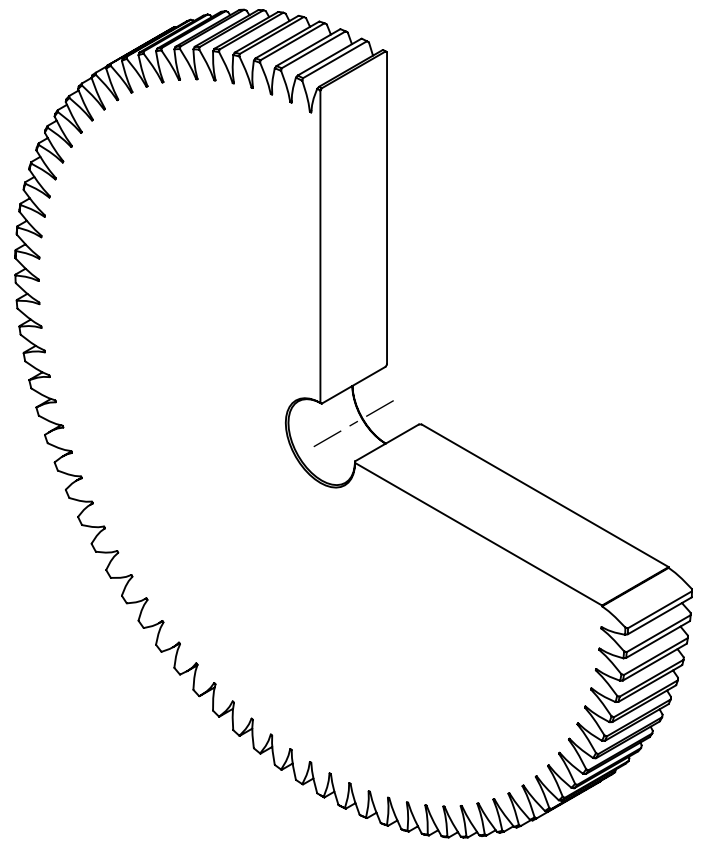
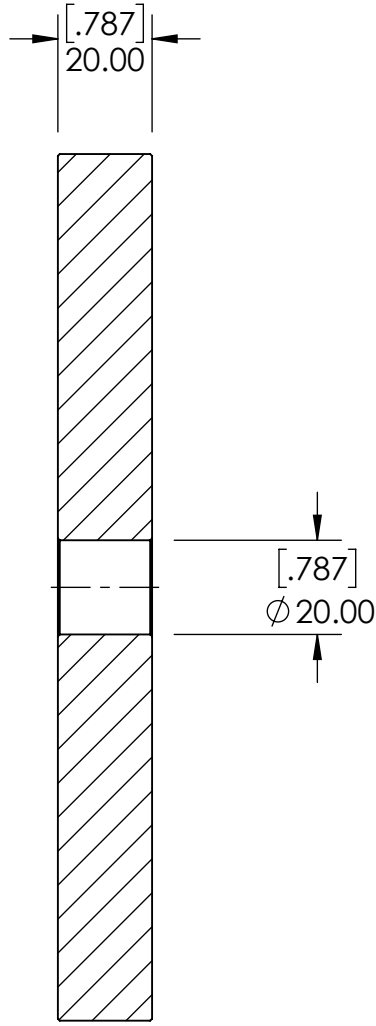
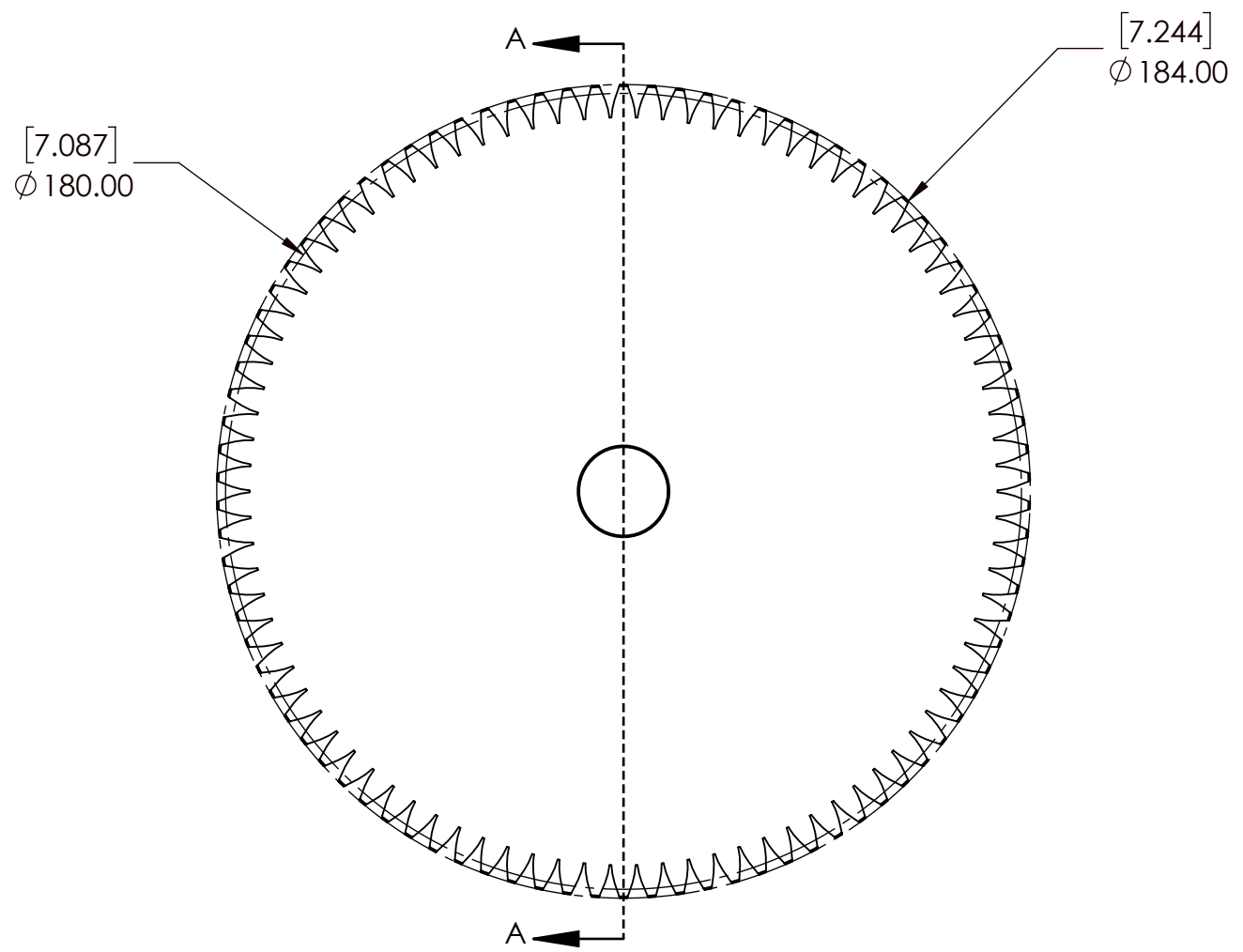

A B C D E F G

9 8 7 6 5 4 3 2 1

SPUR GEAR SPECIFICATIONS		WEIGHT		DATE		BY		REVISION DESCRIPTION		REV
UNITS	mm	MATERIAL	STEEL							
MODULE	2	COATING	N/A							
PRESSURE ANGLE	20°	DRAWN	SEC	08/29/2025						
NUMBER OF TEETH	90	CHECKED	SEC	08/29/2025						
PITCH DIAMETER	180mm	APPROVED								
HUB TYPE	A									
MAX TORQUE (Nm)	180 Nm									
TOOTH TYPE	STRAIGHT									
MAX RIM SPEED	12 M/S									
DWG. NO.		PROPRIETARY AND CONFIDENTIAL		ITEM DESCRIPTION:		M2A90		SCALE		1:1
		THE INFORMATION CONTAINED IN THIS DRAWING IS THE SOLE PROPERTY OF SOLVE IMG. ANY REPRODUCTION IN PART OR AS A WHOLE WITHOUT THE WRITTEN PERMISSION OF SOLVE IMG IS PROHIBITED.						REV		-

