

9 8 7 6 5 4 3 2 1

G F E D C B A

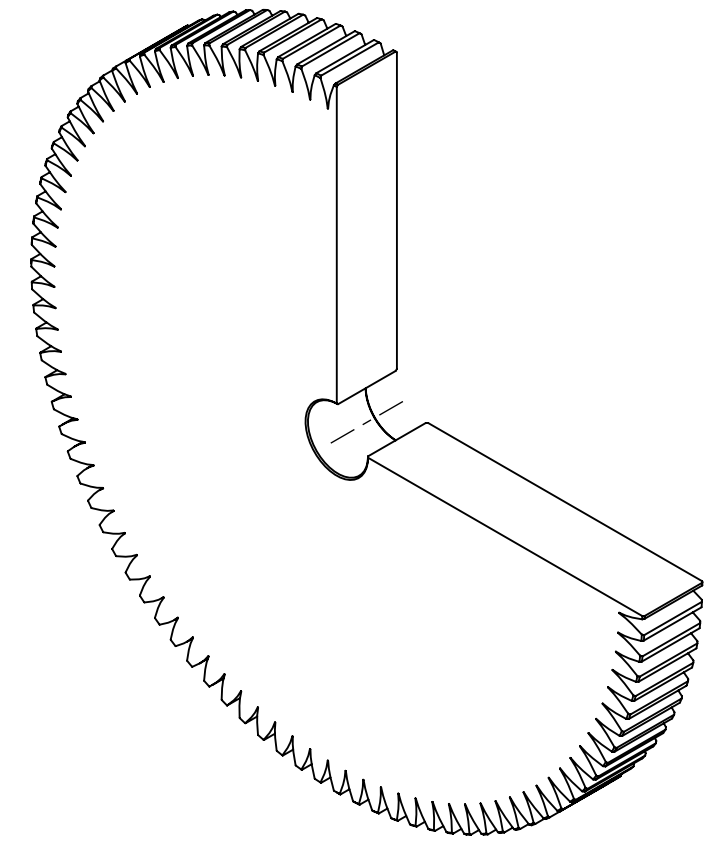
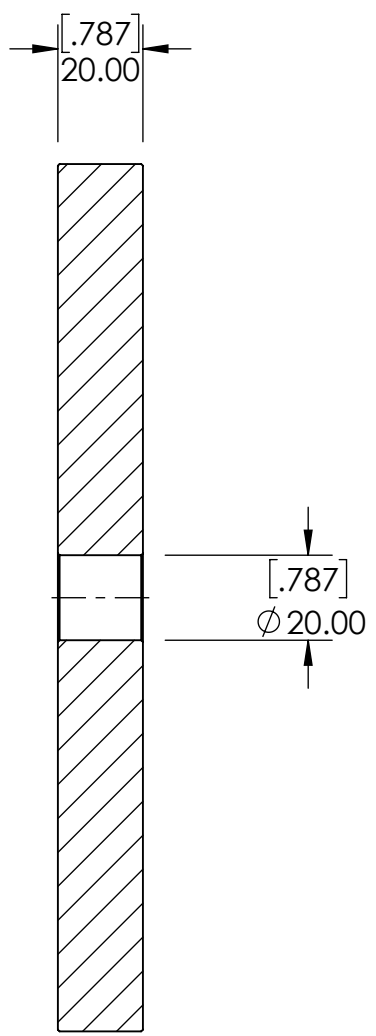
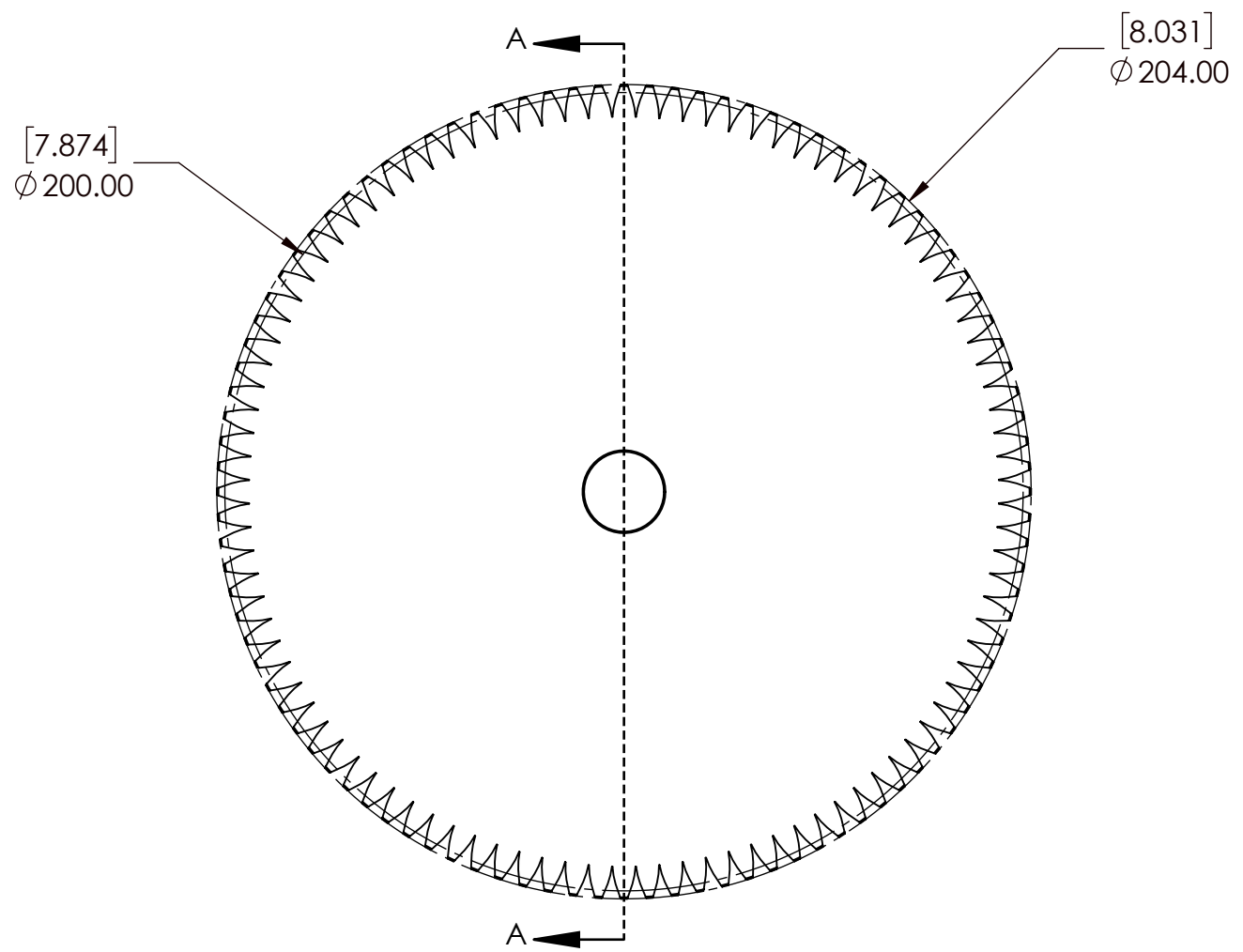

A B C D E F G

9 8 7 6 5 4 3 2 1

SPUR GEAR SPECIFICATIONS		SECTION A-A		WEIGHT	10.58 LBS				
UNITS	mm	SOLVE		MATERIAL	STEEL				
MODULE	2	INDUSTRIAL MOTION GROUP		COATING	N/A				
PRESSURE ANGLE	20°	SIZE	PTI	DRAWN	SEC 08/29/2025				
NUMBER OF TEETH	100			CHECKED	SEC 08/29/2025				
PITCH DIAMETER	200mm	DWG. NO.		APPROVED		DATE	BY	REVISION DESCRIPTION	REV
HUB TYPE	A								
MAX TORQUE (Nm)	185 Nm	DWG. NO.		THIRD ANGLE PROJECTION		ITEM DESCRIPTION:			SCALE
TOOTH TYPE	STRAIGHT			M2A100			1:1		
MAX RIM SPEED	12 M/S			PROPRIETARY AND CONFIDENTIAL					REV
				THE INFORMATION CONTAINED IN THIS DRAWING IS THE SOLE PROPERTY OF SOLVE IMG. ANY REPRODUCTION IN PART OR AS A WHOLE WITHOUT THE WRITTEN PERMISSION OF SOLVE IMG IS PROHIBITED.					-