

9 8 7 6 5 4 3 2 1

G F E D C B A

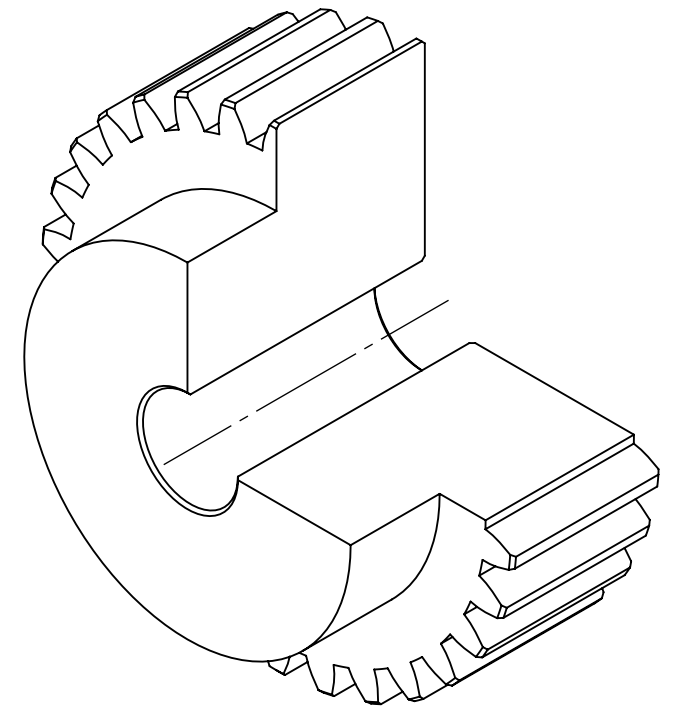
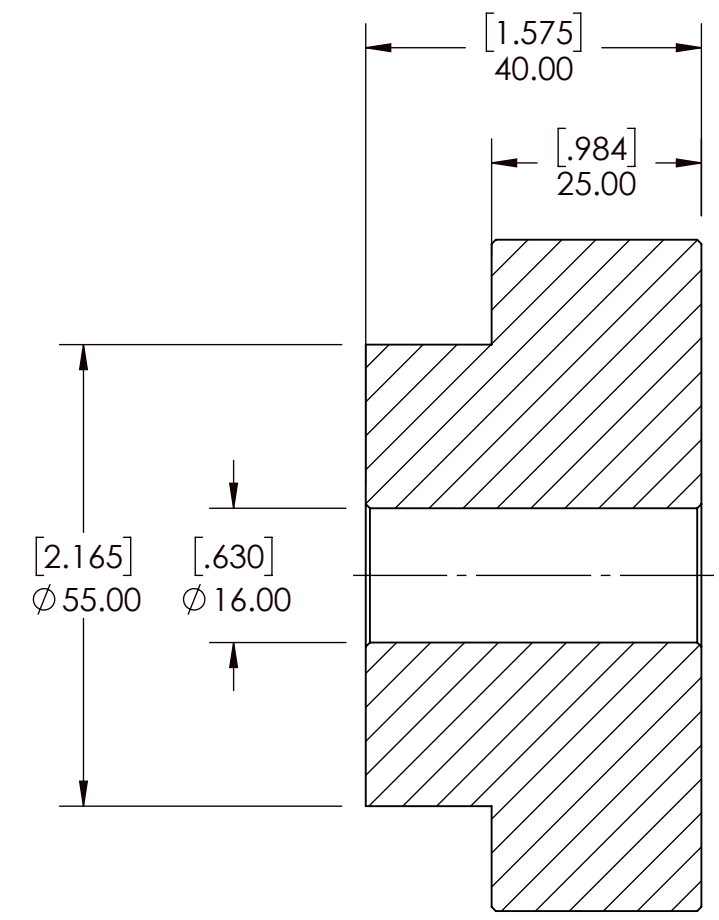
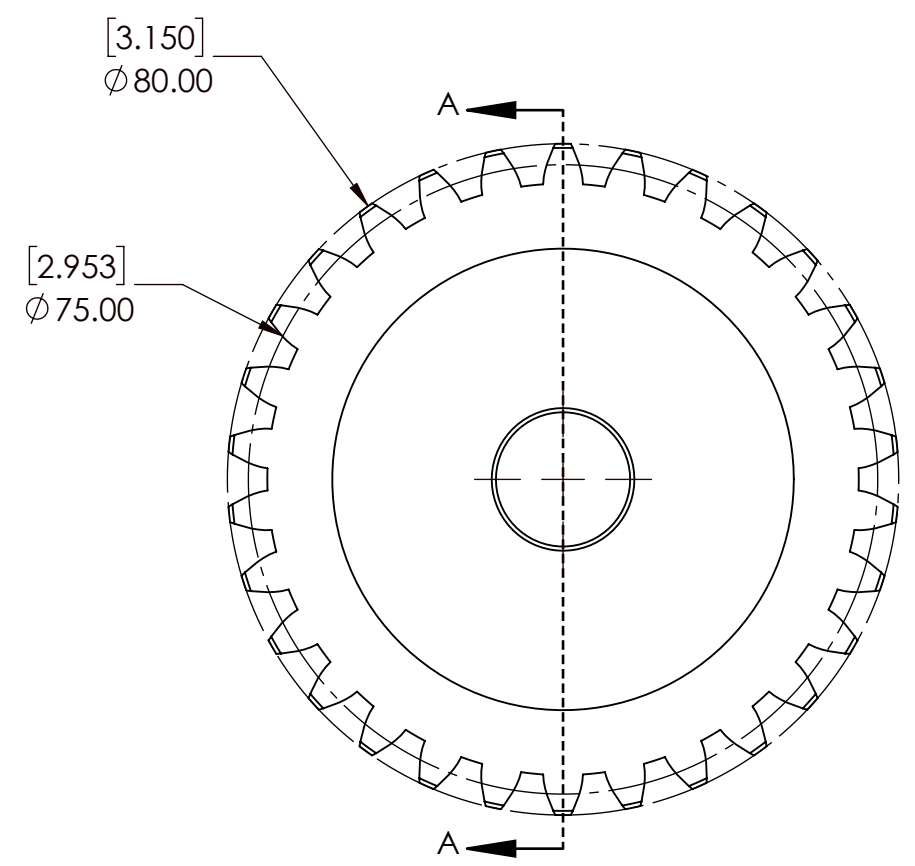

SECTION A-A

SPUR GEAR SPECIFICATIONS		WEIGHT		DATE		BY		REVISION DESCRIPTION		REV
UNITS	mm (INCH)	2.38 LBS								
MODULE	2.5	STEEL								
PRESSURE ANGLE	20°	N/A								
NUMBER OF TEETH	30	DRAWN SEC 08/28/2025								
PITCH DIAMETER	75mm	CHECKED SEC 08/28/2025								
HUB TYPE	B	APPROVED								
MAX TORQUE (Nm)	34.90 Nm	THIRD ANGLE PROJECTION								
TOOTH TYPE	STRAIGHT									
MAX RIM SPEED	12 M/S									
				ITEM DESCRIPTION:		M2.5B30				SCALE
				DWG. NO.						1:1
		<small>PROPRIETARY AND CONFIDENTIAL THE INFORMATION CONTAINED IN THIS DRAWING IS THE SOLE PROPERTY OF SOLVE IMG. ANY REPRODUCTION IN PART OR AS A WHOLE WITHOUT THE WRITTEN PERMISSION OF SOLVE IMG IS PROHIBITED.</small>								REV
										-

9 8 7 6 5 4 3 2 1

A B C D E F G