

9 8 7 6 5 4 3 2 1

G
F
E
D
C
B
A

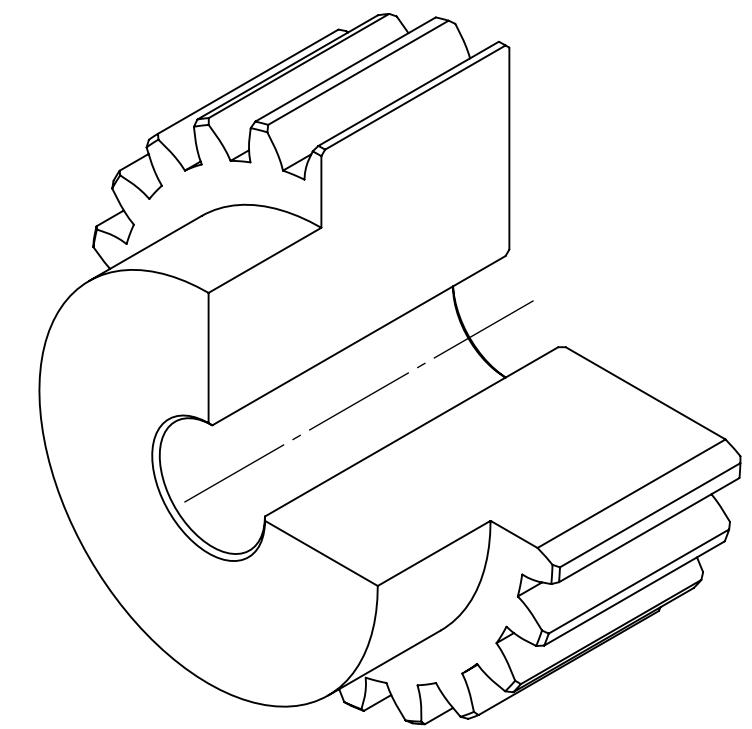
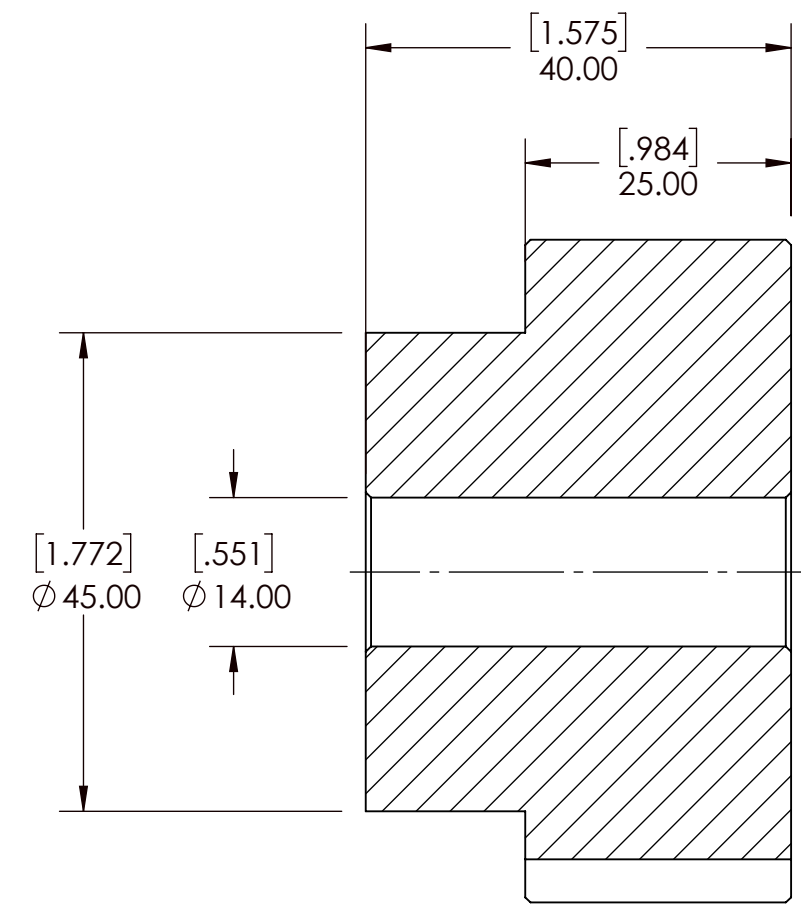
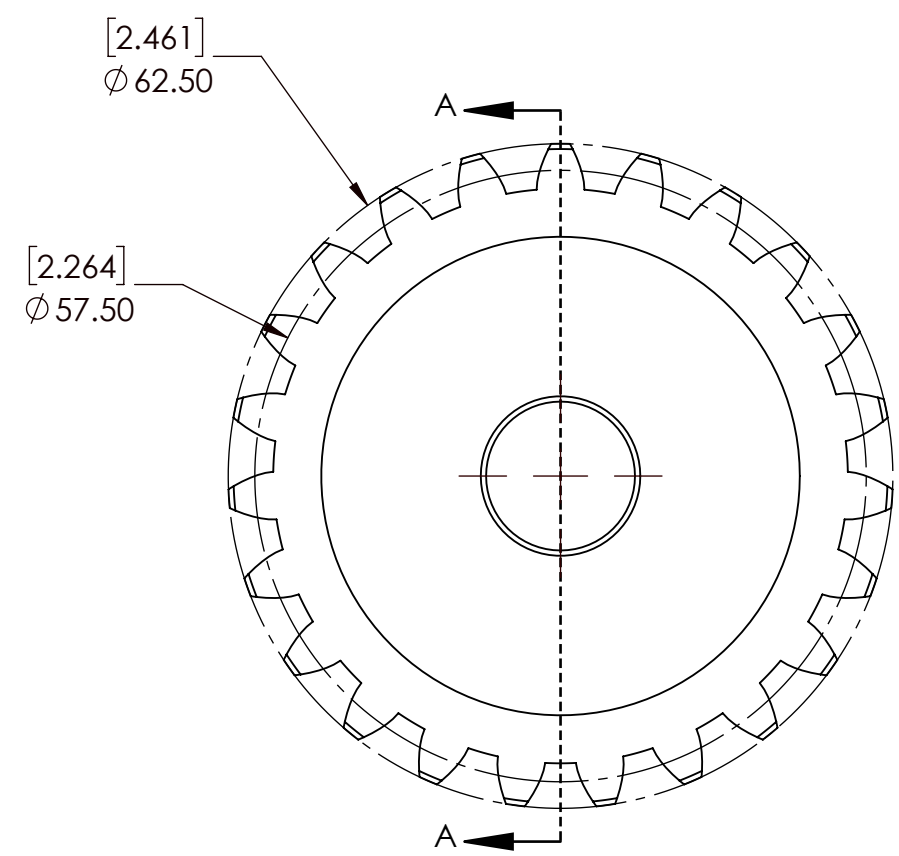

SECTION A-A

SPUR GEAR SPECIFICATIONS		WEIGHT		1.44 LBS	
UNITS	mm (INCH)	MATERIAL	STEEL		
MODULE	2.5	COATING	N/A		
PRESSURE ANGLE	20°	DRAWN	SEC	08/28/2025	
NUMBER OF TEETH	23	CHECKED	SEC	08/28/2025	
PITCH DIAMETER	57.5mm	APPROVED			
HUB TYPE	B	THIRD ANGLE PROJECTION			
MAX TORQUE (Nm)	18.70 Nm	DATE	BY	REVISION DESCRIPTION	
TOOTH TYPE	STRAIGHT	ITEM DESCRIPTION:		M2.5B23	REV
MAX RIM SPEED	12 M/S	DWG. NO.			SCALE
					1:1
		<small>PROPRIETARY AND CONFIDENTIAL THE INFORMATION CONTAINED IN THIS DRAWING IS THE SOLE PROPERTY OF SOLVE IMG. ANY REPRODUCTION IN PART OR AS A WHOLE WITHOUT THE WRITTEN PERMISSION OF SOLVE IMG IS PROHIBITED.</small>			REV
					-

9 8 7 6 5 4 3 2 1