

9 8 7 6 5 4 3 2 1

G

F

E

D

C

B

A

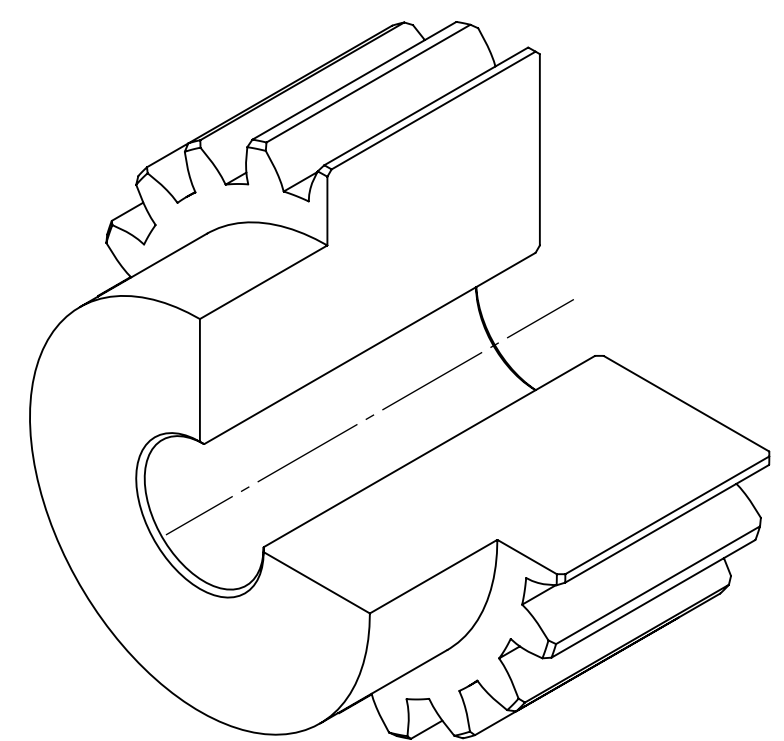
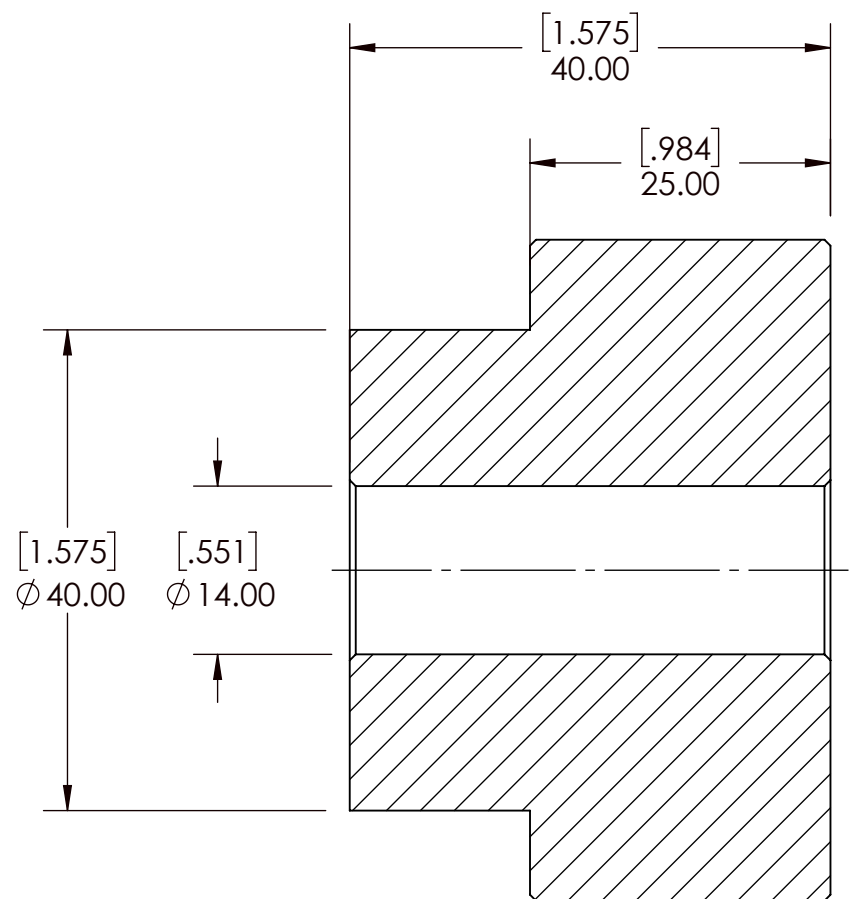
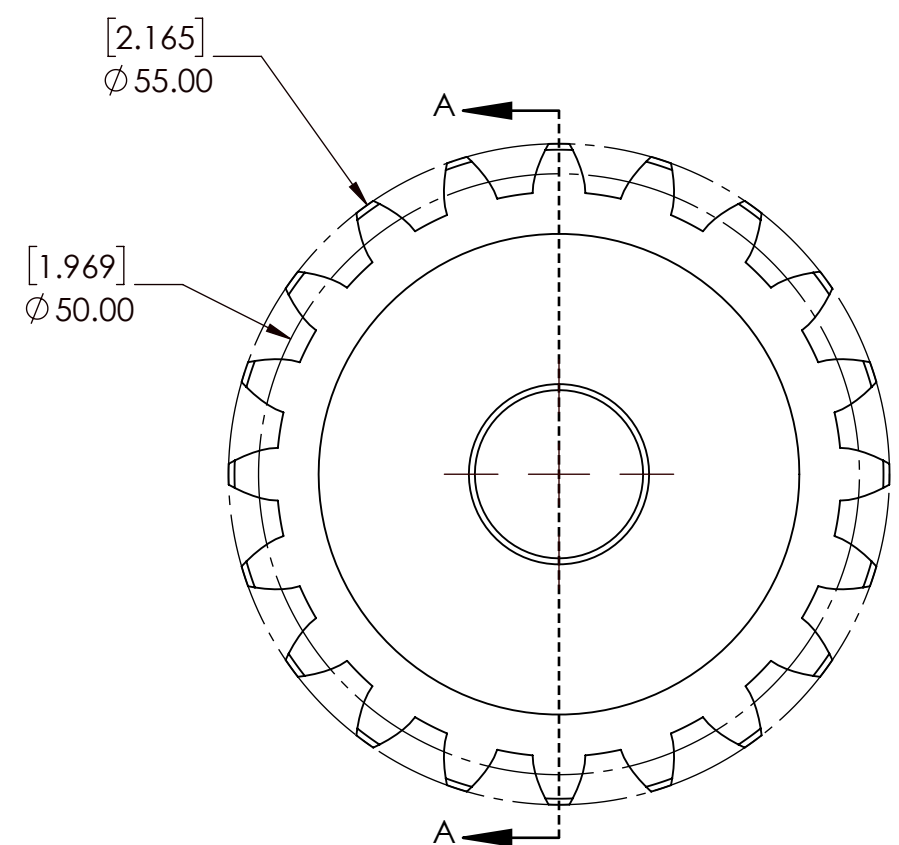

SECTION A-A

SPUR GEAR SPECIFICATIONS		WEIGHT		1.08 LBS					
UNITS	mm (INCH)	MATERIAL		STEEL					
MODULE	2.5	COATING		N/A					
PRESSURE ANGLE	20°	DRAWN	SEC	08/28/2025					
NUMBER OF TEETH	20	CHECKED	SEC	08/28/2025					
PITCH DIAMETER	50mm	APPROVED				DATE	BY	REVISION DESCRIPTION	
HUB TYPE	B					ITEM DESCRIPTION:		M2.5B20	
MAX TORQUE (Nm)	13.40 Nm								
TOOTH TYPE	STRAIGHT	DWG. NO.		PROPRIETARY AND CONFIDENTIAL <small>THE INFORMATION CONTAINED IN THIS DRAWING IS THE SOLE PROPERTY OF SOLVE IMG. ANY REPRODUCTION IN PART OR AS A WHOLE WITHOUT THE WRITTEN PERMISSION OF SOLVE IMG IS PROHIBITED.</small>					
MAX RIM SPEED	12 M/S								

9 8 7 6 5 4 3 2 1