

9 8 7 6 5 4 3 2 1

G
F
E
D
C
B
A

G
F
E
D
C
B
A

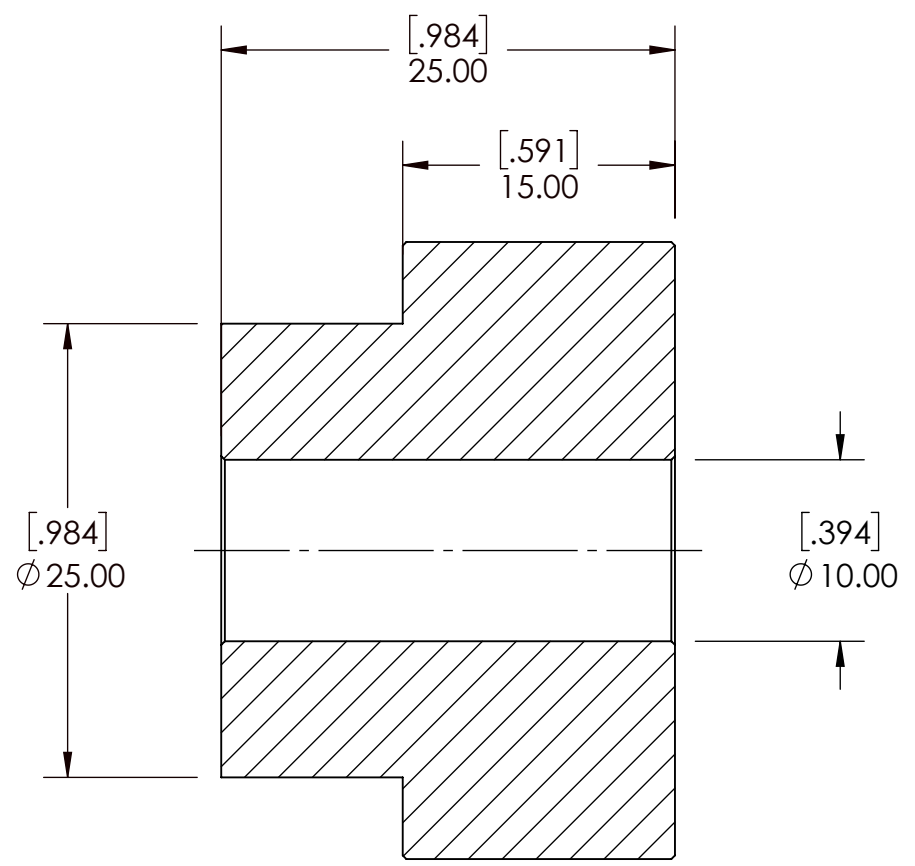
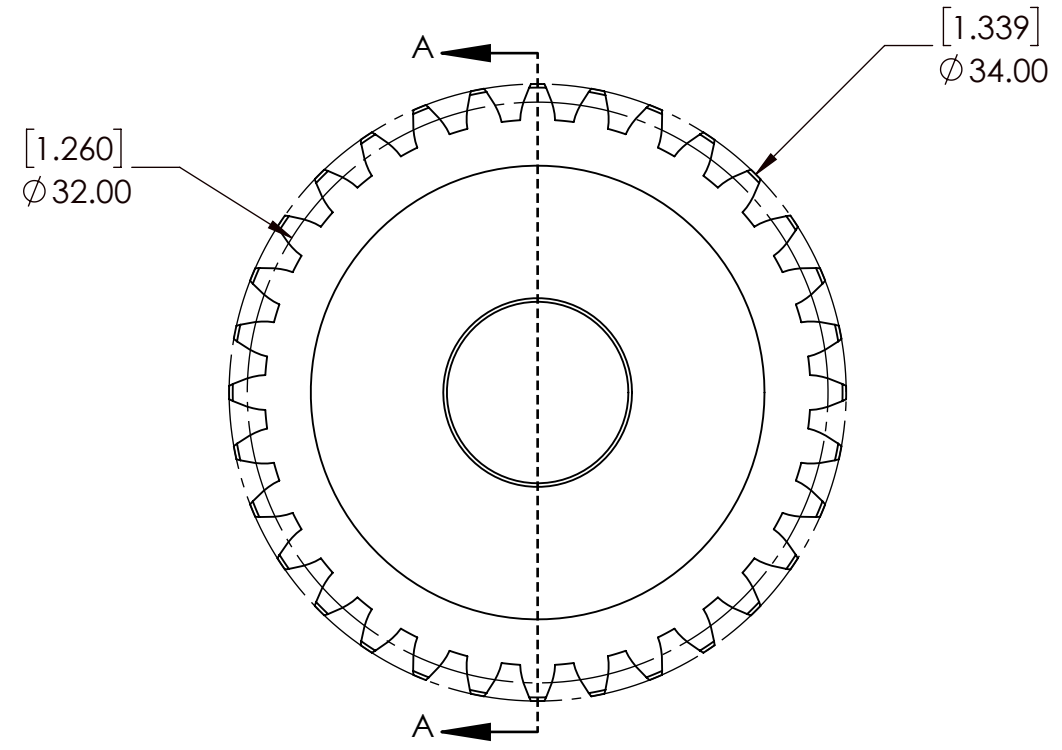
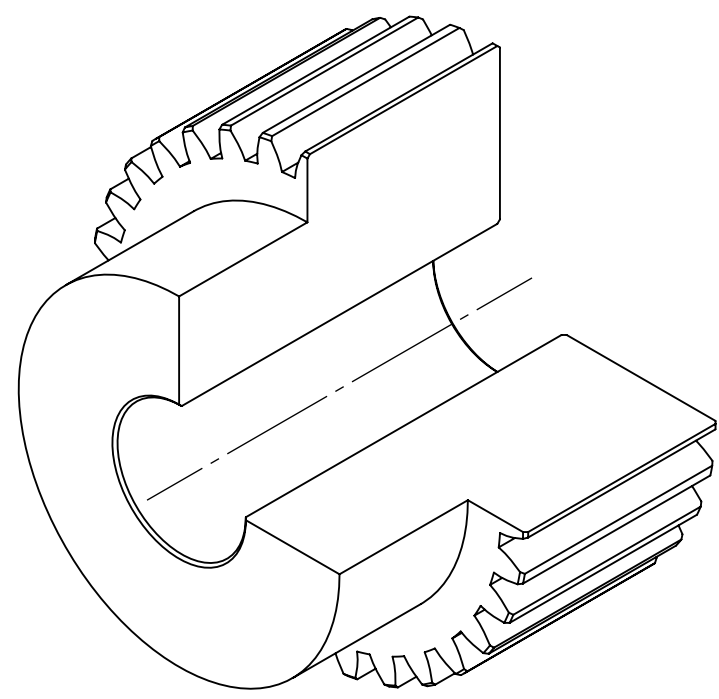

SECTION A-A

SPUR GEAR SPECIFICATIONS		SOLVE		WEIGHT	0.26 LBS				
UNITS	mm (INCH)	INDUSTRIAL MOTION GROUP		MATERIAL	STEEL				
MODULE	1			COATING	N/A				
PRESSURE ANGLE	20°	SIZE	PTI	DRAWN	SEC 08/28/2025				
NUMBER OF TEETH	32			CHECKED	SEC 08/28/2025				
PITCH DIAMETER	32mm	DWG. NO.		APPROVED		DATE	BY	REVISION DESCRIPTION	REV
HUB TYPE	B								
MAX TORQUE (Nm)	2.43 Nm	DWG. NO.		THIRD ANGLE PROJECTION		ITEM DESCRIPTION: M1B32			SCALE
TOOTH TYPE	STRAIGHT			PROPRIETARY AND CONFIDENTIAL					
MAX RIM SPEED	12 M/S			THE INFORMATION CONTAINED IN THIS DRAWING IS THE SOLE PROPERTY OF SOLVE IMG. ANY REPRODUCTION IN PART OR AS A WHOLE WITHOUT THE WRITTEN PERMISSION OF SOLVE IMG IS PROHIBITED.					REV
									-

9 8 7 6 5 4 3 2 1