

9 8 7 6 5 4 3 2 1

G
F
E
D
C
B
A

G
F
E
D
C
B
A

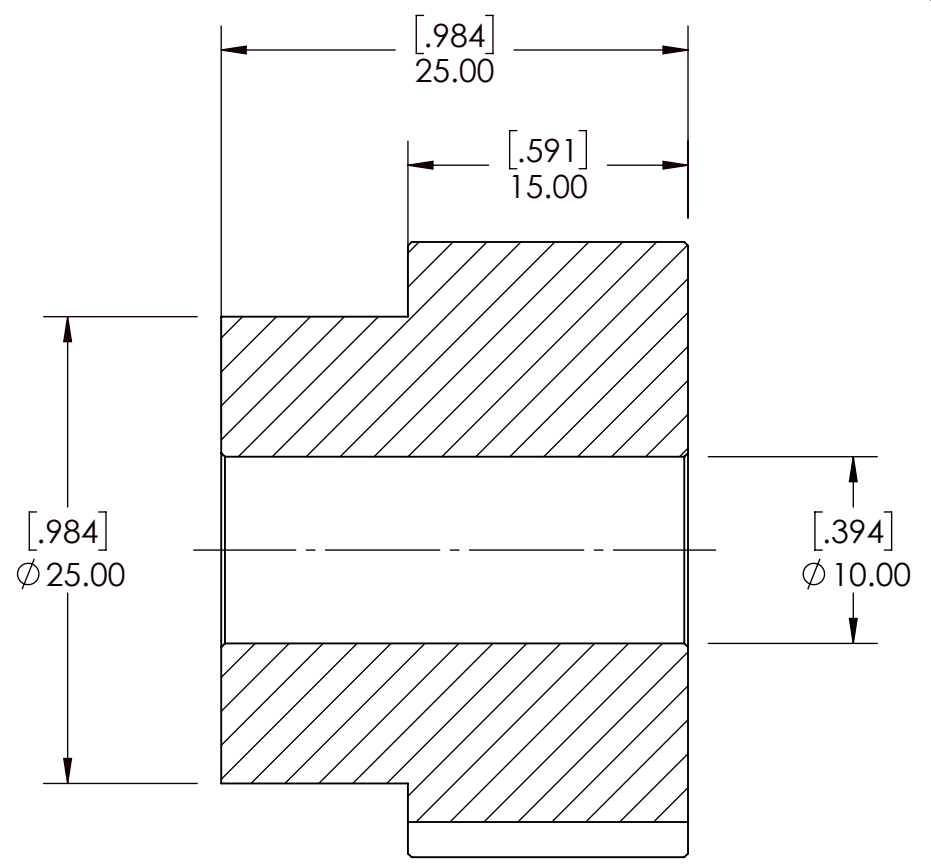
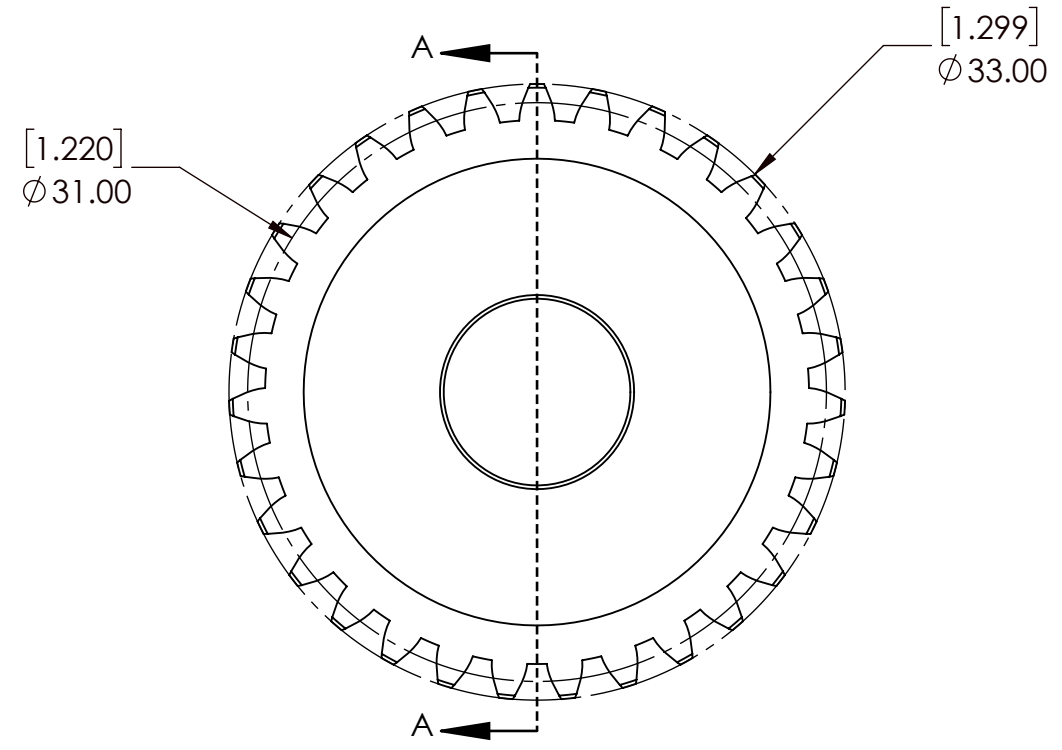
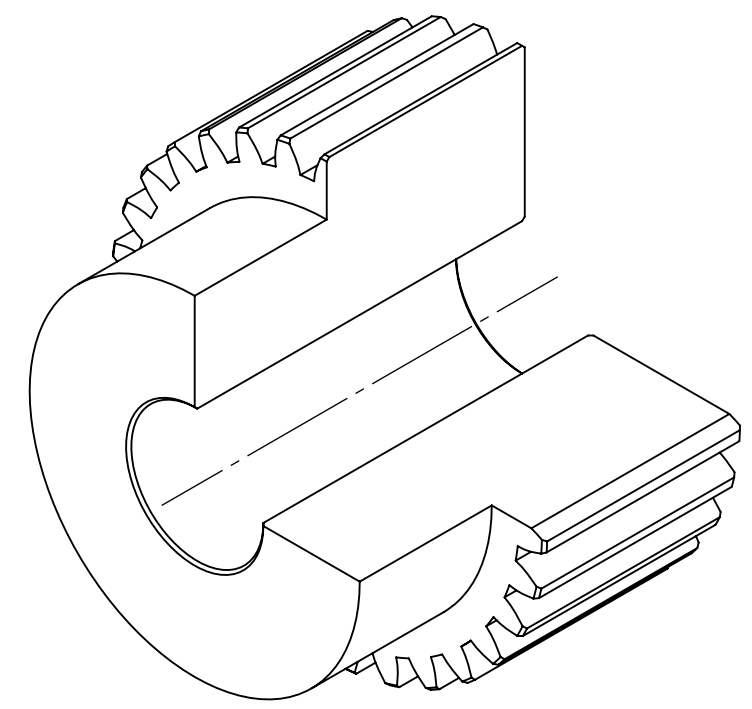

SECTION A-A

SPUR GEAR SPECIFICATIONS		WEIGHT		DATE		BY		REVISION DESCRIPTION		REV	
UNITS	mm (INCH)	0.25 LBS									
MODULE	1	STEEL									
PRESSURE ANGLE	20°	N/A									
NUMBER OF TEETH	31	DRAWN SEC 08/28/2025									
PITCH DIAMETER	31mm	CHECKED SEC 08/28/2025									
HUB TYPE	B	APPROVED									
MAX TORQUE (Nm)	2.24 Nm					ITEM DESCRIPTION:		M1B31		SCALE	
TOOTH TYPE	STRAIGHT									DWG. NO.	
MAX RIM SPEED	12 M/S	PROPRIETARY AND CONFIDENTIAL <small>THE INFORMATION CONTAINED IN THIS DRAWING IS THE SOLE PROPERTY OF SOLVE IMG. ANY REPRODUCTION IN PART OR AS A WHOLE WITHOUT THE WRITTEN PERMISSION OF SOLVE IMG IS PROHIBITED.</small>								REV	
											-

9 8 7 6 5 4 3 2 1