

9 8 7 6 5 4 3 2 1

G
F
E
D
C
B
A

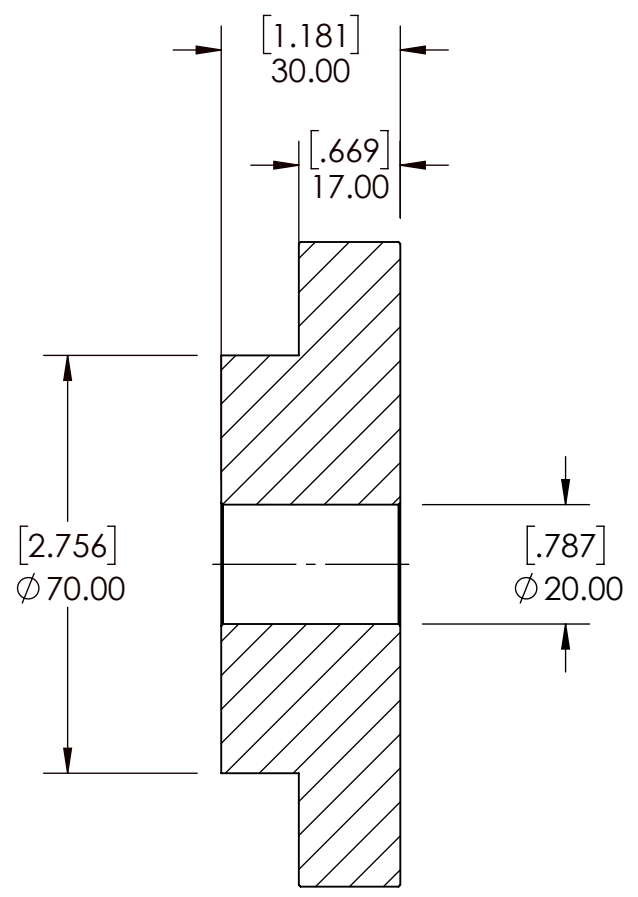
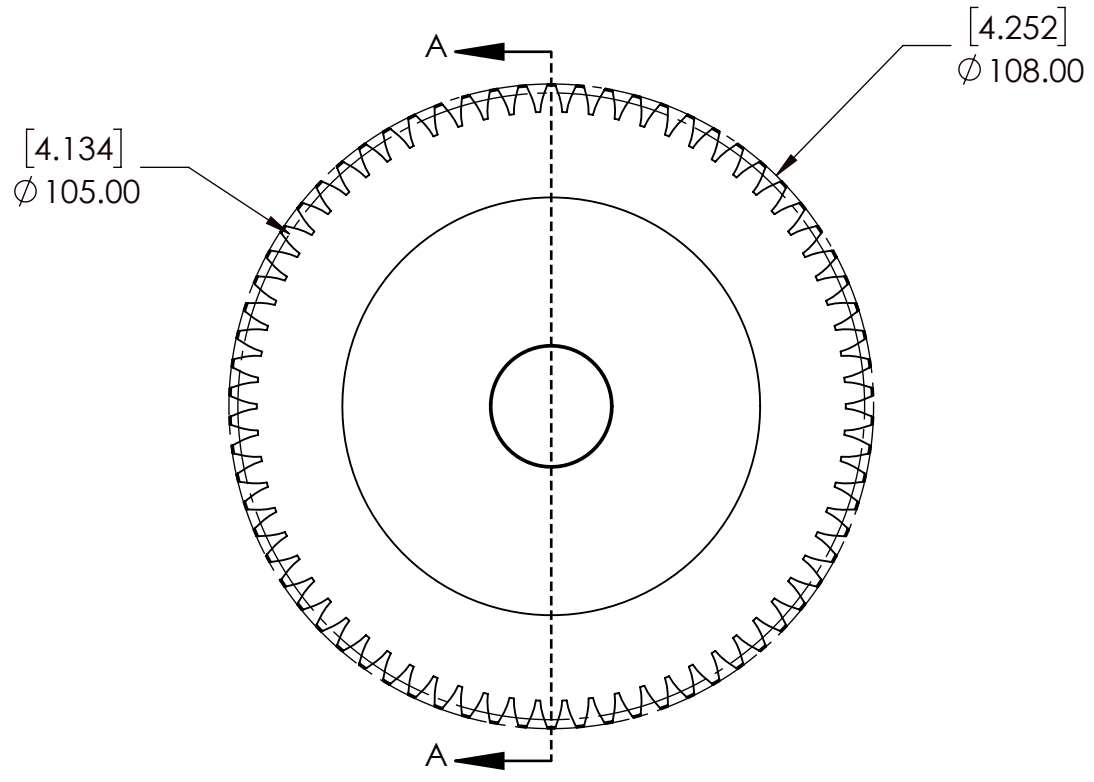
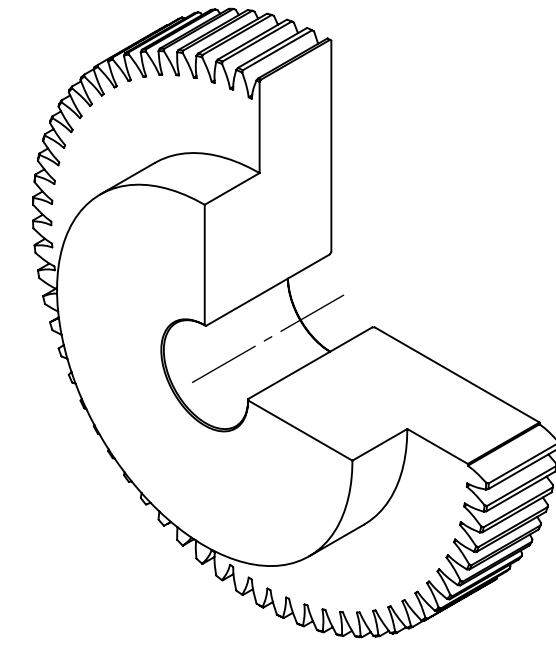

SECTION A-A

SPUR GEAR SPECIFICATIONS		WEIGHT		DATE		BY		REVISION DESCRIPTION		REV
UNITS	mm (INCH)	3.19 LBS								
MODULE	1.5	STEEL								
PRESSURE ANGLE	20°	N/A		08/29/2025						
NUMBER OF TEETH	70	DRAWN		SEC						
PITCH DIAMETER	105mm	CHECKED		SEC						
HUB TYPE	B	APPROVED								
MAX TORQUE (Nm)	53.7 Nm	THIRD ANGLE PROJECTION								
TOOTH TYPE	STRAIGHT	DWG. NO.		PROPRIETARY AND CONFIDENTIAL		ITEM DESCRIPTION:		M1.5B70		SCALE
MAX RIM SPEED	12 M/S	PTI		THE INFORMATION CONTAINED IN THIS DRAWING IS THE SOLE PROPERTY OF SOLVE IMG. ANY REPRODUCTION IN PART OR AS A WHOLE WITHOUT THE WRITTEN PERMISSION OF SOLVE IMG IS PROHIBITED.						1:1
										REV
										-

9 8 7 6 5 4 3 2 1

G
F
E
D
C
B
A